



US 20100328665A1

(19) **United States**

(12) **Patent Application Publication**
Kaye et al.

(10) **Pub. No.: US 2010/0328665 A1**

(43) **Pub. Date: Dec. 30, 2010**

(54) **FLUID-BORNE PARTICLE DETECTOR**

(30) **Foreign Application Priority Data**

(76) Inventors: **Paul Henry Kaye, Herts (GB);**
Warren Roy Stanley, Herts (GB)

Jan. 25, 2008 (GB) 0801375.7

Publication Classification

Correspondence Address:
JOHN S. PRATT, ESQ
KILPATRICK STOCKTON, LLP
1100 PEACHTREE STREET, SUITE 2800
ATLANTA, GA 30309 (US)

(51) **Int. Cl.**
G01N 21/00 (2006.01)

(52) **U.S. Cl.** **356/342**

(21) Appl. No.: **12/864,064**

(57) **ABSTRACT**

(22) PCT Filed: **Jan. 22, 2009**

(86) PCT No.: **PCT/GB2009/000158**

§ 371 (c)(1),
(2), (4) Date: **Aug. 18, 2010**

There is disclosed improved apparatus and methods for detection of shape, size and intrinsic fluorescence properties of a fluid borne particle wherein the apparatus comprises a laser, two light sources, two detectors, and optionally a third detector. The apparatus is particularly suitable for detection of airborne biological particles.

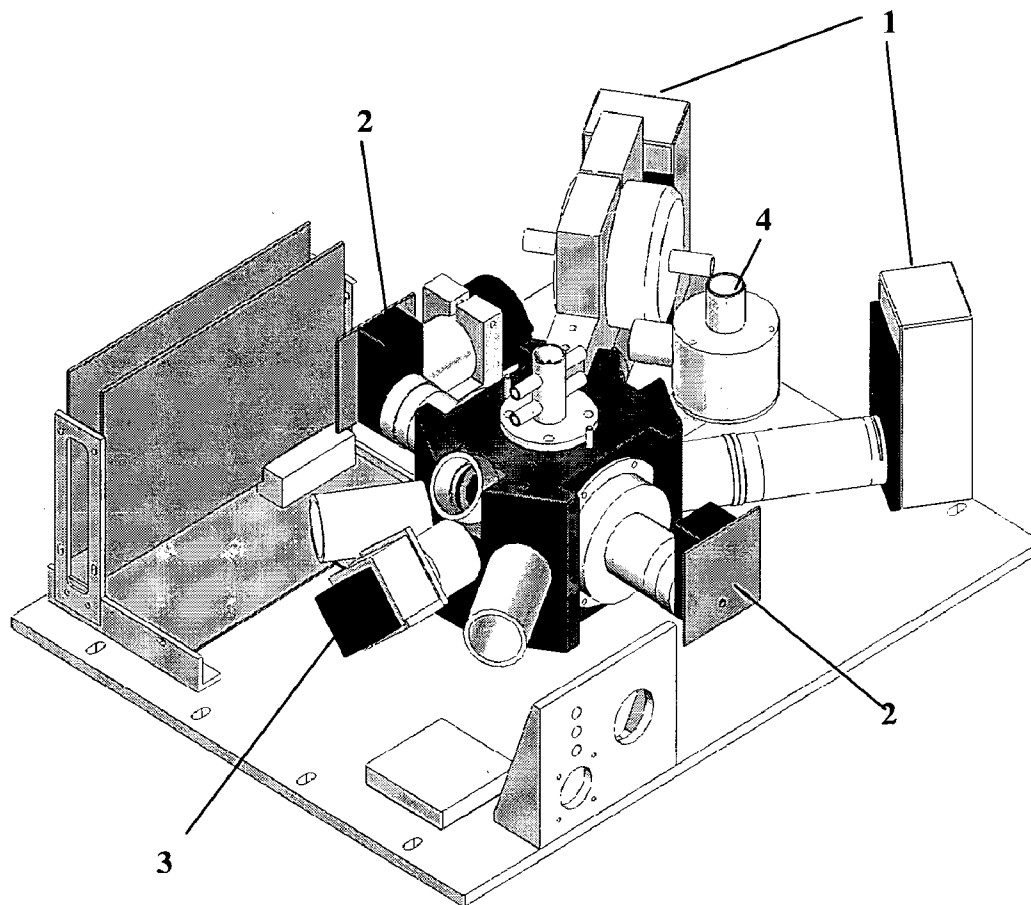

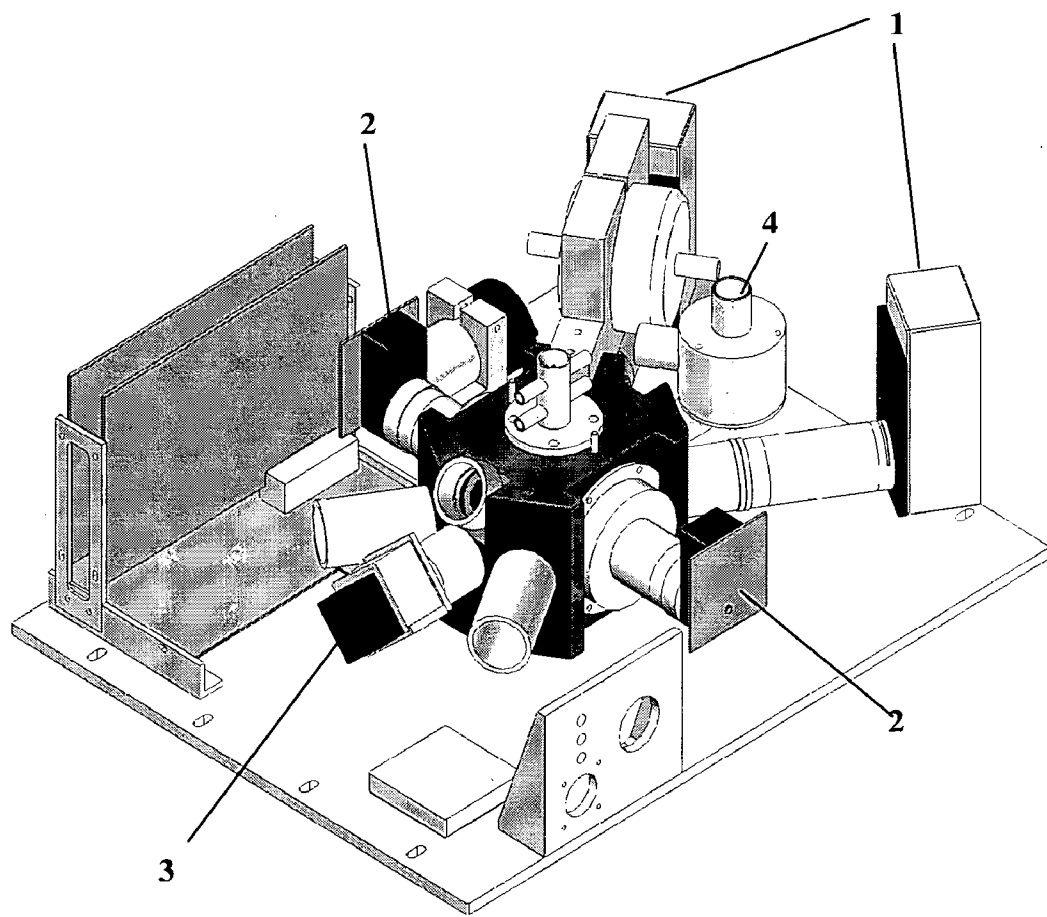

Figure 1

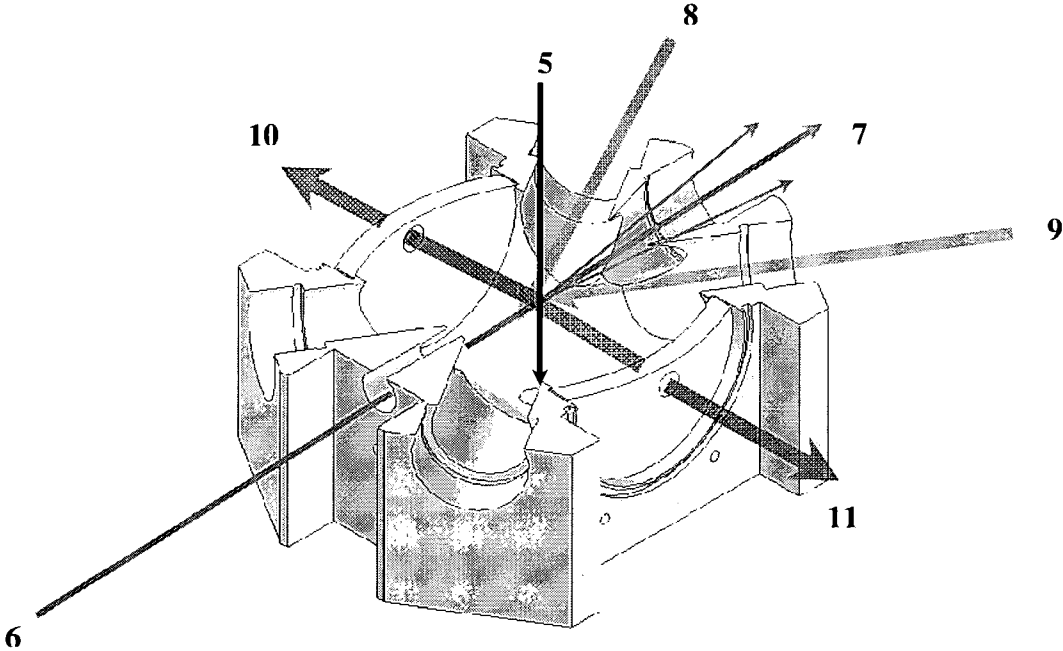

Figure 2

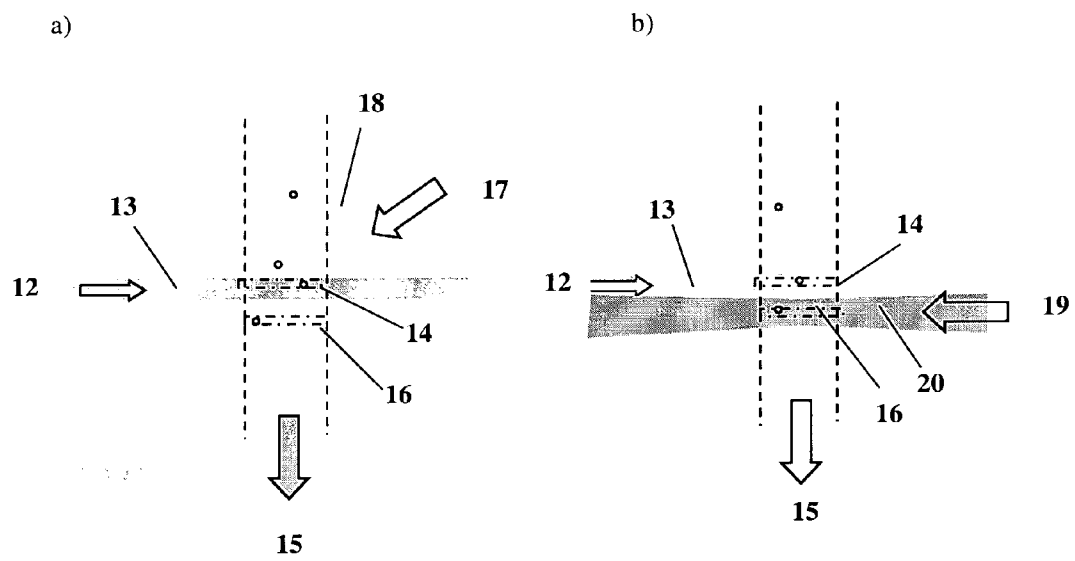

Figure 3

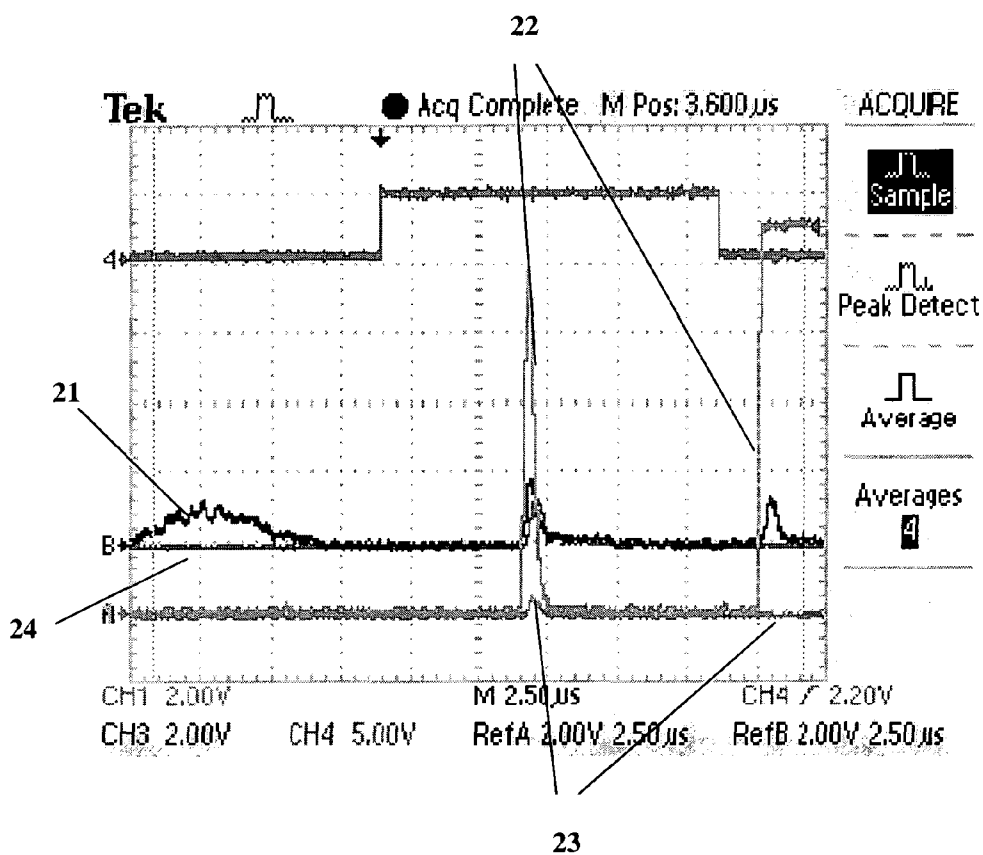

Figure 4

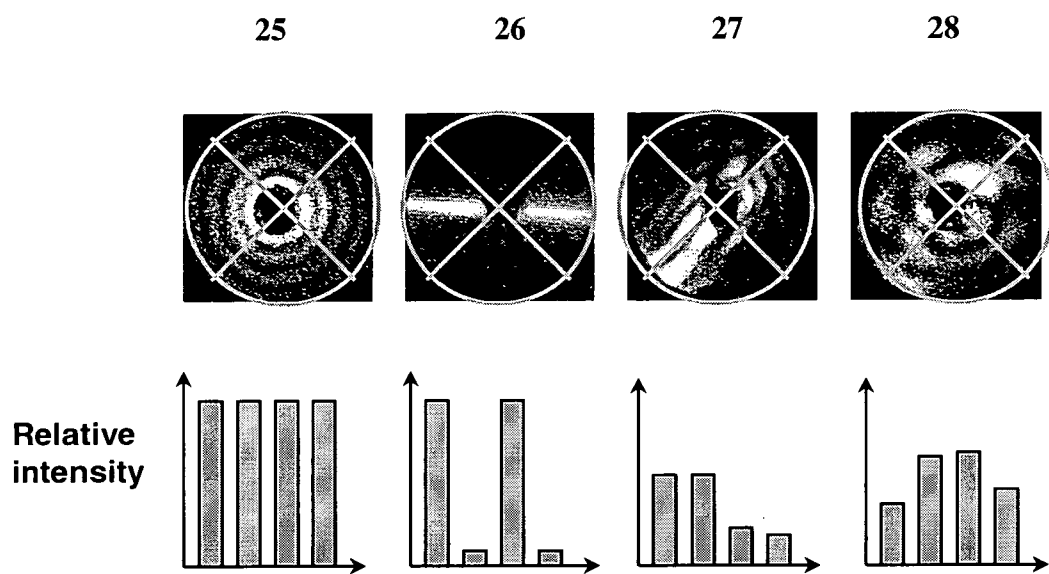

Figure 5

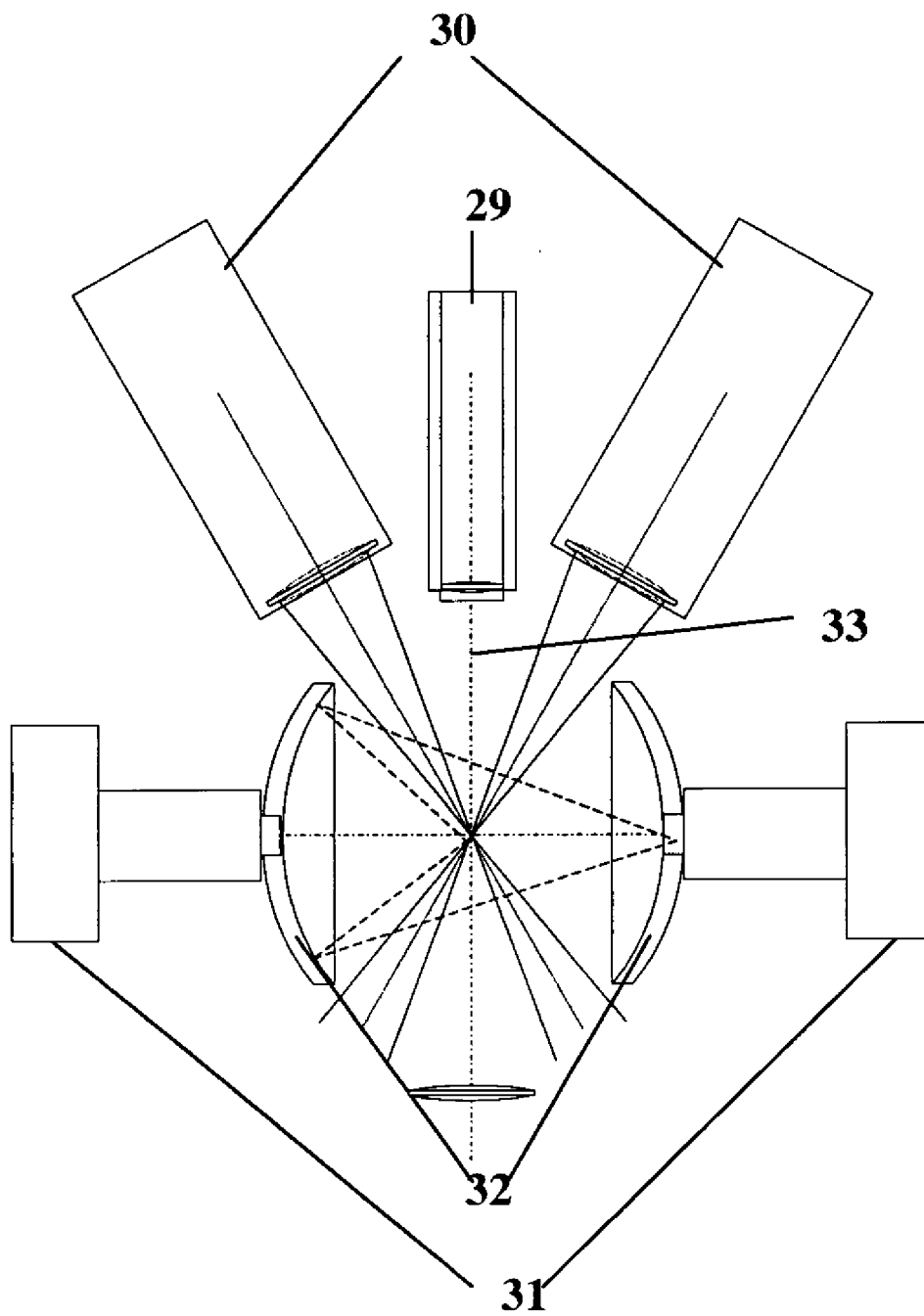

Figure 6

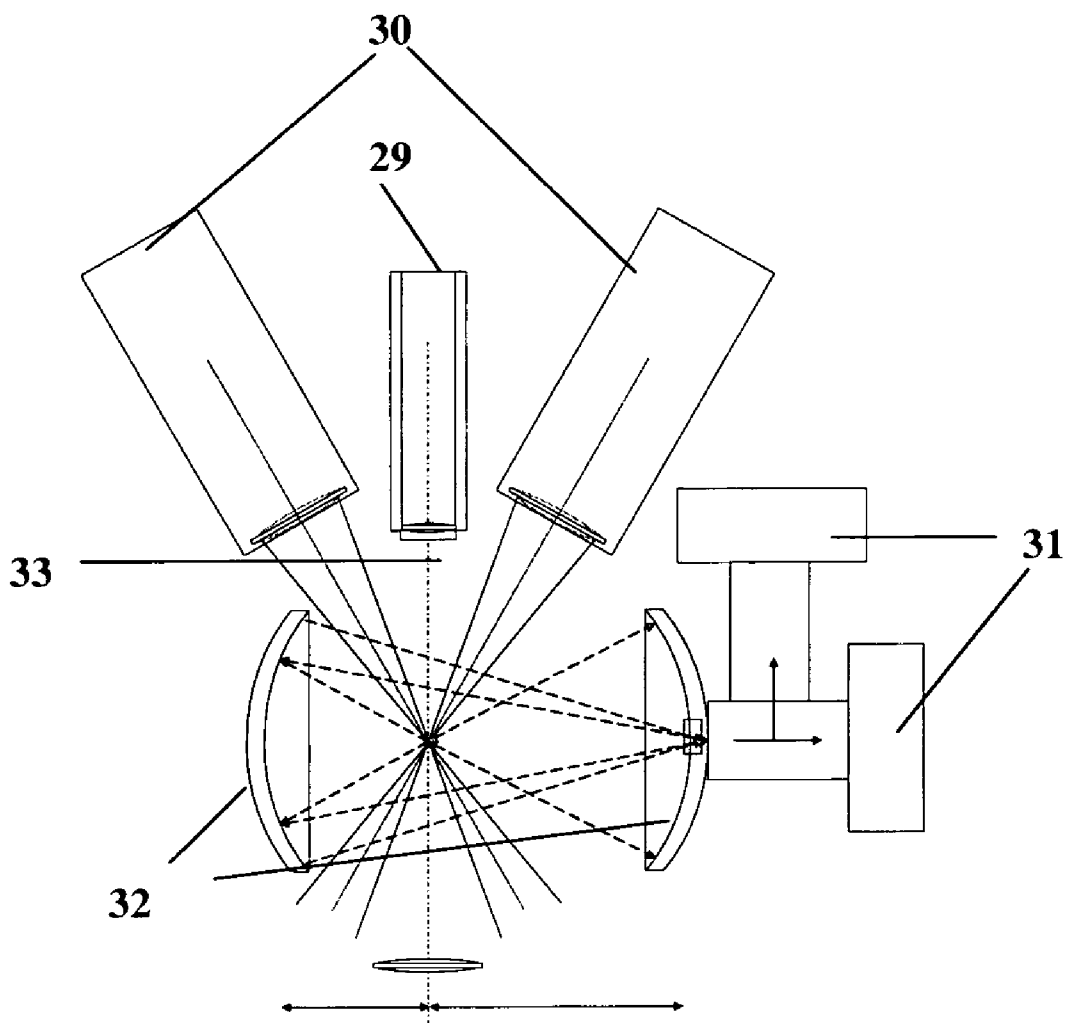

Figure 7

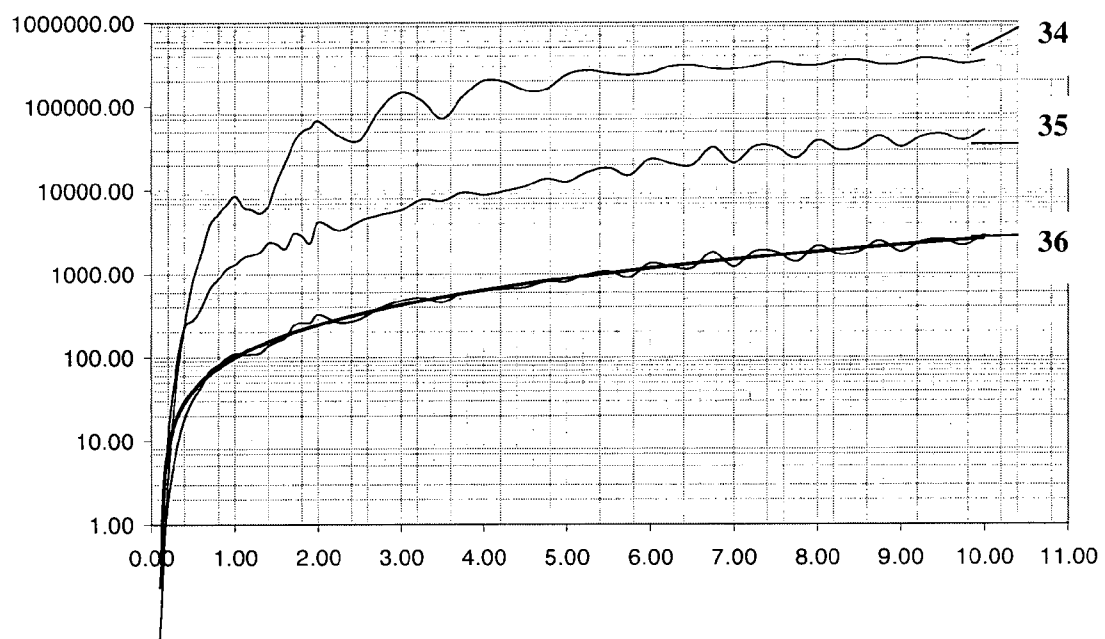

Figure 8

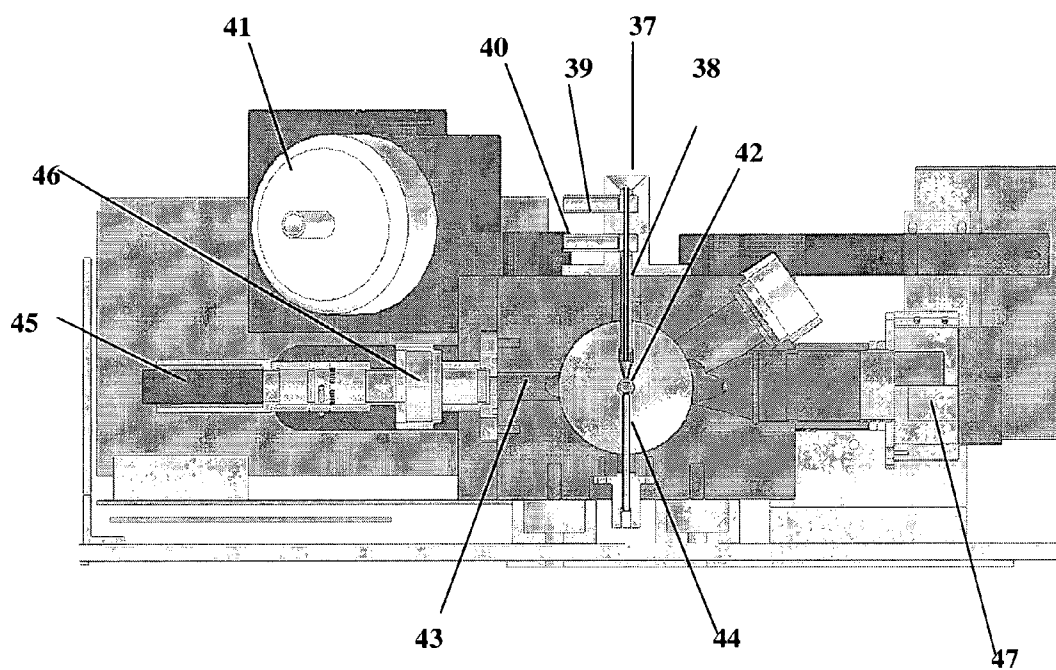

Figure 9

FLUID-BORNE PARTICLE DETECTOR

[0001] This invention is concerned with improvements in apparatus and methods for detecting and classifying fluid borne particles, especially airborne particles, and is particularly concerned with detection of single biological particles.

[0002] In a world increasingly concerned with pollution, global warming and terrorism the requirement for reliable, accurate and sensitive techniques for detecting, and more importantly identifying airborne particles has never been more important. A significant amount of effort has been spent in developing and improving techniques and apparatus for achieving such detection over the years, but the requirement for more sensitive, compact, economical and cost-effective apparatus still exists.

[0003] Airborne particles include inter alia mineral dusts, combustion products and biological particles. In order to discriminate between airborne particles of different types methods have been developed which measure multiple parameters from individual particles, using means such as light scattering or fluorescence. International Patent Application PCT/GB2004002761 (Published as WO 2005/001436), incorporated in its entirety by reference herein, discloses apparatus for detecting fluid borne particles comprising a pair of coaxially opposed concave reflective surfaces having central apertures about a detection zone, two xenon light sources of differing wavelength band arranged to irradiate particles within the zone, and two opposed detectors either side of and substantially aligned with the reflective surfaces, arranged such that fluorescent light reflected from the concave reflective surfaces through the central aperture of the opposite concave reflective surface is received by a detector. The apparatus is capable of classifying particles in terms of their size (elastic scatter) and dual-wavelength intrinsic fluorescence properties. Detection of single particles using such an arrangement may be achieved by incorporation of a trigger to detect the presence of separate particles in the detection zone, such a trigger may be provided by a continuous wave diode laser such as described in Kaye P. H. et al Proceedings SPIE European Symposium Optics/Photonics in Security and Defence Bruges, September 2005, 59900 N1-N12. A timing sequence is then required to enable sequential illumination of a single particle by the two xenon light sources as the particle flows through the detection zone of the apparatus.

[0004] Apparatus disclosed in International Patent Application PCT/GB2004002761 was designed for analysis in outdoor environments and especially areas of military conflict whereby a biological threat may appear anywhere. For this purpose the apparatus was required to be of sufficiently low cost and small size so that it may be manufactured in large numbers for utilisation over a wide area of potential risk. Such an apparatus would also optimally be hand portable, require no or minimal reagents, be capable of unattended operation and continuous operation for approximately 48 hours. The apparatus also had to be sensitive and provide a rapid detection response.

[0005] The present invention generally aims to provide compact apparatus capable of sensitively detecting and classifying single particles through fluorescence and light scattering. The invention in particular aims to improve classification capability and compactness provided by apparatus disclosed in International Patent Application PCT/GB 2004002761.

[0006] Accordingly, in a first aspect, the present invention provides an apparatus for detection of a fluid borne particle comprising

[0007] i. a pair of coaxially opposed concave reflective surfaces about a zone whereby flow means are provided for delivering a fluid flow comprising the fluid borne particle through the zone;

[0008] ii. a laser arranged to illuminate the fluid flow in the zone;

[0009] iii. a first and second detector wherein the first detector is arranged to detect scattered and/or emitted light of a first wavelength band emanating from the zone and the second detector is arranged to detect scattered and/or emitted light of a second wavelength band emanating from the zone;

[0010] iv. a first and second light source wherein the first source is arranged to illuminate the fluid flow in the zone with light of a third wavelength band and the second source is arranged to illuminate the fluid flow in the zone with light of a fourth wavelength band

[0011] whereby the laser and the first and second light source are each arranged in a plane substantially orthogonal to the direction of the fluid flow provided for by the flow means.

[0012] Advantageously, the coaxially opposed concave reflective surfaces comprise central apertures such that light emanating from the zone, most likely produced through irradiation of the particle, is focussed by the concave reflective surfaces through the central aperture of the opposite concave reflective surface. The first and second detector are advantageously arranged to detect light focussed through the central aperture of the opposed concave reflective surfaces. Preferably, the axis linking the centre of the opposed concave reflective surfaces is substantially aligned with the axis linking the detectors. The axis linking the centre of the opposed concave reflective surfaces is also preferably substantially orthogonal to the axis of illumination from the laser. These features either singularly or combined facilitate efficient collection and detection of light scattered or emitted by particles within the zone of the apparatus.

[0013] The laser and the first and second light source are each arranged in a plane substantially orthogonal to the direction of the fluid flow provided for by the flow means to provide for optimal focussing of the first and second light sources onto a specific volume of the fluid flow that is illuminated by the laser. The laser illuminates a specific volume of the fluid which as a result of the laser being in a plane substantially orthogonal to the fluid flow appears as approximately a flat cylinder or disk shape. A light source also in a plane substantially orthogonal to the fluid flow will require the minimum width of light beam to illuminate the whole specific volume of the flat cylinder shape, and therefore be of optimal power for producing fluorescence and detection.

[0014] Embodiments of the first aspect of the invention may have the laser and the first and second light source situated such that the laser and first and second light sources are each in a plane vertically offset with respect to each other. Alternatively, the laser and the first and second light sources may be substantially in the same plane but the resulting light beams from the laser and the first and second light source may each be in a plane vertically offset with respect to each other. The resulting light beams from the laser and the first and second light source may be vertically offset to allow for movement of the particle under the influence of the fluid flow

between triggering of the laser, the first light source and the second light source. Thus a particle illuminated and sensed by the light beam from the laser at a first position in the zone may be illuminated by the light beam from the first light source at a second position in the zone downstream of the first position, and may be illuminated by the light beam of the second light source at a third position in the zone downstream of the second position.

[0015] In a preferred embodiment however the laser and two light sources are substantially arranged in a single plane substantially orthogonal to the direction of the fluid flow provided for by the flow means. This provides amongst other advantages for a more compact apparatus. Furthermore, apparatus of the present invention having the laser and the two light sources substantially arranged in a single plane provides an increase in sensitivity of approximately six-fold over that of the apparatus disclosed in International Patent Application PCT/GB2004002761 and Kaye P. H. et al Proceedings SPIE European Symposium Optics/Photonics in Security and Defence Bruges, September 2005, 59900 N1-N12.

[0016] In a preferred embodiment the two detectors are each arranged in a plane substantially orthogonal to the direction of the fluid flow provided for by the flow means, and in a more preferred embodiment the two detectors are in the same plane as the laser and the first and second light source. Such an embodiment provides for a compact arrangement of features, and therefore more compact apparatus. Apparatus having the laser, the first and second light source, and the two detectors all in a single plane is in particular more compact, approximately half the volume, than apparatus disclosed in the cited prior art documents.

[0017] The first and second light source preferably comprise a xenon light source element and preferably a low pass filter between the light source and the zone to allow passage of a wavelength band in a selected range only.

[0018] The apparatus is particularly suitable for detecting an airborne particle, and especially a biological particle such as a bacterial cell, bacterial spore, bacterial cell fragment or a virus containing particle.

[0019] One use of the apparatus is the classification of biological particles through intrinsic fluorescent properties of molecules present within the particle. Two of the most useful molecules are tryptophan and nicotinamide adenine dinucleotide (NADH) which fluoresce upon irradiation with wavelengths of approximately 280 nm and 370 nm, respectively, resulting in fluorescence emission between about 300 to 400 nm for tryptophan and about 400 to 600 nm for NADH. Thus in one embodiment the third wavelength band may be shorter in wavelength than the first wavelength band and the second wavelength band, and/or the fourth wavelength band may be shorter in wavelength than the second wavelength band, and/or the fourth wavelength band may be within the first wavelength band.

[0020] In one embodiment, the first and second light sources are xenon lamps such as miniature xenon flash lamps which may be focussed down to a few mm² and deliver the necessary high UV fluence (approximately 200-300 μJ/sr/cm²) required to achieve an adequate fluorescence response from a biological particle in a 1 μs duration of illumination. The third wavelength band is preferably about 280 nm and the fourth wavelength band preferably about 370 nm, as these are wavelength bands suitable for exciting tryptophan (280 nm) and NADH (370 nm).

[0021] The first wavelength band and the second wavelength band may overlap, however preferably the first wavelength band and the second wavelength band are not overlapping. Overlapping wavelength bands may result in an increase of low-level background broadband fluorescence emanating from objects other than the particle itself, becoming manifest as noise incorporated in each measurement. Furthermore, and for substantially the same reasons, the first wavelength band and second wavelength band are relatively narrow in range. In one embodiment suitable for detecting intrinsic fluorescence from tryptophan and NADH the first wavelength band is approximately 300 to 400 nm and the second wavelength band is approximately 420 to 600 nm.

[0022] The laser preferably provides for a continuous wave laser beam to identify the presence of a single particle in the zone, and may for example be a 635 nm continuous wave diode laser.

[0023] The apparatus may further comprise a third detector for detecting forward scattered light as a result of illuminating the particle by the laser and/or the first or second light source. Such a detector is capable of providing an assessment or even identification of the shape of the particle, and therefore provides for improved apparatus over that disclosed in the cited prior art. The third detector may for example comprise a quadrant photomultiplier tube detector. The third detector may assess particle shape through analysis of azimuthal light scattering from the particle. In an embodiment of the apparatus wherein the second detector is capable of detecting back or side (elastic) scattered light the apparatus may further comprise feedback means between the second detector and the third detector such that the feedback means provides for accurate measurement and identification of particle size. The second detector may for example be capable of detecting back or side scattered light when the wavelength of the laser light beam is within the wavelength band of the second detector (the second wavelength band): scattered light resulting from illumination of a particle with the laser could therefore be detected at the second detector. The combination of two different detectors for recording size and shape measurement through light scattering is capable of reducing the effect of Mie oscillations in a sizing response curve and therefore is capable of providing a more reliable particle size measurement.

[0024] Preferably the apparatus further comprises a processor configured to operate the apparatus whereby triggering and/or timing of illumination from the laser and the first and second light sources are controlled. The processor may also be programmed to process light signals received at the first and second detector, and where applicable the third detector.

[0025] In a second aspect, the present invention provides a method for detection of a fluid borne particle comprising sequentially illuminating a fluid flow with a laser, a first light source and a second light source, whereby the laser illuminates a specific volume of the fluid flow and records the presence of the fluid borne particle and the first light source and the second light source illuminate the specific volume to elicit fluorescent signals from the particle which are detected by suitable means for light detection, whereby the laser, first light source and second light source are each arranged in a plane substantially orthogonal to the fluid flow.

[0026] It should be noted that in a fluid flow the specific volume, in which the presence of a fluid-borne particle is detected by the light beam from the laser, will move as a result of the flow of the fluid and thus the light beam from the first

and/or second light source, or both may have to be focussed such as to compensate for this movement. For example, the laser and the first and second light source may be situated with respect to each other such that the laser and first and second light sources are vertically offset. Alternatively, the laser and the first and second light sources may be substantially in the same plane but the resulting light beams from the laser and the first and second light source may be vertically offset.

[0027] In a preferred embodiment the method utilises apparatus of the first aspect of the invention.

[0028] In a third aspect, the present invention provides a use of apparatus of the first aspect for detecting fluid-borne particles.

[0029] In a preferred embodiment, the fluid is air, and in a further preferred embodiment the particles are biological particles.

[0030] The present invention will now be described with reference to the following examples and drawings in which

[0031] FIG. 1 is a drawing of one embodiment of the present application;

[0032] FIG. 2 is an image indicating the geometry of one aspect of the present invention wherein the fluid flow is substantially orthogonal to a plane comprising a laser, two light sources and three detectors;

[0033] FIG. 3 *a*) and *b*) are schematics comparing apparatus of the cited prior art (*a*) wherein illumination of particles is with a laser in a plane substantially orthogonal to the direction of the fluid flow but a xenon light source not in a plane substantially orthogonal to the direction of the fluid flow, and an embodiment of the present invention (*b*) wherein illumination of particles is with a laser and a xenon light source each in a plane substantially orthogonal to the direction of the fluid flow;

[0034] FIG. 4 is a graph representing light intensity recorded at a first detector and a second detector against time for one embodiment of the present invention;

[0035] FIG. 5 is a diagram indicating light scattering patterns recorded with a quadrant detector for particles of different shape;

[0036] FIG. 6 is a diagram indicating the spatial arrangement of components of one embodiment of the present invention in a horizontal plane;

[0037] FIG. 7 is a diagram indicating the spatial arrangement of components of another embodiment of the present invention in a horizontal plane;

[0038] FIG. 8 is a graph of relative light flux (y axis) against particle diameter (x axis; μm), and shows the theoretical response for a quadrant photomultiplier tube detecting forward scattered light 34, a second photomultiplier tube detecting back or side scattered light 35, and a mathematical combination 36 of these two responses for identifying particle size; and

[0039] FIG. 9 is a cross-sectional view of one embodiment of the apparatus of the present invention showing, in particular, features providing for an aerosol to be delivered to the detection zone.

EXAMPLES

[0040] Referring now to FIG. 1, an embodiment of the present invention for measuring the size, shape and intrinsic fluorescence from individual particles comprises two xenon light sources 1, two detectors 2, a quadrant detector 3 and a laser (not visible in the figure) all in a single plane wherein the plane is substantially orthogonal to the fluid flow within the detection zone of the apparatus. An aerosol inlet 4 is also present for providing the fluid flow, i.e. the airflow. Wavebands of the two xenon light sources are 280 nm and 370 nm, and are selected to excite the biofluorophores tryptophan and NADH. One detector is arranged to record a wavelength band between approximately 300 and 400 nm, and the other detector a wavelength band between approximately 420 and 600 nm. The apparatus is in particular for detecting particle sizes between about 0.5 μm to 10 μm . Maximum throughput for a complete fluorescence measurement is 125 particles/second (limited by xenon recharge time), and corresponds to all particles for concentrations up to approximately 2×10^4 /litre. This embodiment is half the size of apparatus disclosed in International Patent Application PCT/GB2004002761 and apparatus in Kaye P. H. et al Proceedings SPIE European Symposium Optics/Photonics in Security and Defence Bruges, September 2005, 59900 N1-N12, and has approximately a 6-fold improvement in fluorescence detection sensitivity. The xenon light sources may be arranged on the same side of the apparatus as the laser, as shown, or alternatively on the opposite side of the apparatus, but still in the same plane, as indicated in FIG. 2.

[0041] Referring now to FIG. 2, the geometry of an embodiment of the present invention provides for a fluid flow 5 substantially orthogonal to a plane comprising the laser light beam 6 providing forward scattered light 7 and the xenon light source beams 8 and 9 providing particle fluorescence 10 and 11. The shape of the central component of the apparatus (substantially elongated cylindrical) displayed in FIG. 2 is driven by the requirement to arrange all features around a particular zone, the detection zone of the apparatus, and to provide apparatus as compact as possible. In one embodiment of the invention the central component has dimensions of approximately height 80 mm, width 100 mm, and length 120 mm. The remaining dimensions of this component are driven by the requirement to fit specific components of the apparatus.

[0042] One embodiment of the apparatus of the present invention comprises the components listed in Table 1 arranged around the central component displayed in FIG. 2. This embodiment of the apparatus can be fitted into a container, or box, of dimensions 170 mm height, 300 mm wide and 380 mm long, and thus provides for a compact apparatus which is also hand portable.

TABLE 1

Component list for one embodiment of the present invention.					
Item	Item Description	Use	Supplier	order code	Quantity
Lenses	60 mm fl DCX UV coated	xenon light sources	Edmund Optics	A46-294	4

TABLE 1-continued

Component list for one embodiment of the present invention.					
Item	Item Description	Use	Supplier	order code	Quantity
Filters	25 mm fl DCX UV coated	first detector	Edmund Optics	A46-292	2
	25 mm fl PCX Vis coated	second detector	Edmund Optics	A45-363	1
	30 mm fl PCX Vis coated	second detector	Edmund Optics	A45-098	1
	50 mm fl	diode	Edmund Optics	A46-017	1
	25 mm dia cyl	laser beam shaping	Edmund Optics	A32-478	1
	lens 50 mm fl	third detector	Edmund Optics	A32-480	1
	lens 75 mm fl	third detector	Melles Griot	02WRM001	1
	Quaterwave plate	third detector	Laser2000 (SEMrock)	FF01-280/20-25	2
	Sem 280 filter	first xenon light source	Laser2000 (SEMrock)	FF01-300/LP-25	2
	Sem 304 filter	first detector	HV Skan	DUG11	1
	DUG11 filter	second xenon light source	HV Skan	DUG11	1
	DUG11 filter	first detector	HV Skan	UG11	1
	UG11	first detector	HV Skan	UG11	1
	KV418 filter	second detector	Edmund Optics	A43-469	2
	Mirrors	Edmund visible reflection mirror			
Lens tubes	Thor Iris diaphragms		ThorLabs	SM1D12	2
	25 mm				
	Thor lens tube		ThorLabs	SM1L03	8
	Thor lens tube		ThorLabs	SM1L05	5
	Thor lens tube		ThorLabs	SM1L10	2
	Thor lens tube		ThorLabs	SM1L20	2
	Thor lens tube		ThorLabs	SM1L30	2
	Thor linking pieces		ThorLabs	SM1T2	5
	Thor retaining ring		ThorLabs	SM1RR	20
	Lens tube couplers		ThorLabs	SM05T2	2
Optoelectronics	Lens tube adaptors		ThorLabs	SM1A6	1
	Lens tube endcaps		ThorLabs	SM1CP2	2
	623 nm 12 mW laser	diode laser	Photonic products	401-PM	1
	PMT modules	first and second detector	Hamamatsu	H6779	2
	Xenon light source	first and second light source	Hamamatsu	L9455-01	2
	4-anode PMT	third detector	Hamamatsu	R5900U-01-M4	1
	Socket for 4-anode PMT	third detector	Hamamatsu	E7083	1
HT supply for PMT 12 V	third detector	Hamamatsu	C4900-01	1	
Red LED 12 V	Power and pump indicator	Onecall	882-781	2	

TABLE 1-continued

Component list for one embodiment of the present invention.					
Item	Item Description	Use	Supplier	order code	Quantity
Electrical	Blue LED 12 V	particle detect	Onecall	882-823	1
	Silicon photodiodes BPX65	power monitors	RS	304-346	2
	DC-DC converter	power board	RS	473-5801	1
	Panel mount receptacle, pin contacts	power connector	Onecall	391-1317	1
	Straight plug-pin contacts - solder	power connector	Onecall	391-1688	1
	Plug backshell	power connector	Onecall	391-2127	1
	1 m USB cable type A-B	internal connector	Onecall	107-6669	1
	IP68 B-type USB panel mount connector	USB port	Onecall	966-7750	1
	USB Buccaneer cable IP68 B-type to standard	External USB connector	Onecall	999-7407	1
	Mechanical	Barbed connector/kit	tubing connector	Cole Palmer	KH-31514-02
Barbed elbow/Tee Y connector kit		tubing connector	Cole Palmer	KH-31514-14	1
Airlite 3 lpm diaphragm pump		air movement	SKC Ltd		1
air filters		air filtration	Fisher Scientific	FDP-780-030Q	2

[0043] Referring now to FIG. 3a, apparatus disclosed in the cited prior art comprises a laser 12 providing a laser beam 13 to illuminate a specific volume 14 of a fluid flow 15. The specific volume moves with the fluid flow to a second position, volume 16, at which point a xenon light source 17 illuminates volume 16 to generate fluorescence from a particle initially present in specific volume 14. The xenon light source 17 provides a light beam 18 at an angle (approximately 30 to 45 degrees) to volume 16 and thus the width of light beam 18 is broad to accommodate for this arrangement: volume 16 must be as uniformly illuminated as possible. Referring now to FIG. 3b, apparatus of the present invention also comprises a laser 12 providing a laser beam 13 to illuminate a specific volume 14 of a fluid flow 15. However, a xenon light source 19 is arranged to produce a light beam 20 in the same horizontal plane as laser beam 13 which allows the width of the laser beam to be significantly less broad, and therefore more tightly focussed, whilst retaining full and complete irradiation of volume 16. The effect achieved by this arrangement of features is that a higher intensity of UV light illuminates each particle resulting in an enhanced fluorescence response.

[0044] Now referring to FIG. 4, results produced with the embodiment of FIG. 1, trace 21 is the response of the second detector following illumination of the zone, i.e. the detection zone, of the apparatus with a laser, a first xenon light source and a second xenon light source. The relatively long 10 μ s

signal produced in trace 21 is due to the particle passing through the laser beam and scattering light. The much shorter fluorescence pulses ($\sim 1 \mu$ s) appear due to firing of the two xenon light sources. Trace 22 is the response of the first detector, which upon irradiation with the first xenon light source (280 nm) records a signal corresponding to particle fluorescence in the wavelength band of 300 to 400 nm, and upon irradiation with the second xenon light source (370 nm) records elastically scattered light from the particle, as the wavelength of the second light source falls within the wavelength band of the first detector, which saturates the detector. Trace 23 just visible beneath trace 22 shows the response of the first detector to firing of the two xenon light sources in the absence of a particle. Trace 24 is the response of the second detector to firing of the two xenon light sources in the absence of a particle. Ideally this should result in zero detected signal, however because of imperfect filters and low levels of fluorescence within the scattering chamber itself, a measurable signal is detected. This is one of the factors that ultimately limits the sensitivity of the instrument. This 'background' fluorescence signal is approximately $\frac{1}{20}$ of the signal recorded from a 3 μ m polystyrene calibration particle. For comparison, in the apparatus disclosed in International Patent Application PCT/GB2004002761 and apparatus disclosed in Kaye P. H. et al Proceedings SPIE European Symposium Optics/Photonics in Security and Defence Bruges, September 2005, 59900 N1-N12 the recorded background signal is

approximately $\frac{1}{3}$ of the signal recorded for a 3 mm polystyrene calibration particle, and thus the embodiment of FIG. 1 possesses a 6-fold improvement in sensitivity. The improvement is due to lower levels of stray UV light in the chamber and higher levels of UV fluence on the particle which are both as a result of horizontal alignment of the xenon light sources and the laser, with each feature being present in a plane substantially orthogonal to the direction of the fluid flow, thus allowing the xenon light sources to be focused more tightly.

[0045] The timing sequence for triggering of the laser and the two xenon light sources in order to irradiate (illuminate) a single particle is calculated based on the rate of air flow through the apparatus. A description of the process performed within one embodiment of the apparatus (such as that illustrated in FIG. 1), together with the triggering sequence, is as follows:

[0046] 1. As a particle passes through the 635 nm laser light beam light is scattered in all directions, with forward scattered light falling on the quadrant photomultiplier tube, which provides data for particle detection and assessment of particle shape. Light scattered at a range of angles around ± 90 degrees falls on the two concave mirrors and is reflected through the aperture in the opposing mirror to one of the detectors. The first detector is not capable of detecting the scattered light as due to the specific filter mounted to the detector it is only capable of detecting wavelengths of light between 300 and 400 nm. The second detector however does register this scattered light producing a signal proportional to the amount of light (see broad signal in trace 21 of FIG. 4). This signal is used together with the forward scattered signal (not shown in FIG. 4) at the quadrant photomultiplier tube to determine particle size.

[0047] 2. Approximately 10 μ s after the particle is detected, by scattered light recorded at the second detector, the first xenon light source (280 nm) is triggered to fire. During this 10 μ s period, the particle will have moved approximately 300 μ m and will be below the level of the laser beam. The fluorescence from the particle is collected by both the first and second detectors (see signals in trace 21 and 22 in FIG. 4).

[0048] 3. A further 10 μ s later, the second xenon light source (370 nm) fires, and again the fluorescence excited in the particle by this longer wavelength UV is collected by the first and second detectors (see trace 21 and 22 in FIG. 4). It should be noted that as the second light source has a wavelength band (370 nm) within that of the first detector wavelength band (300 to 400 nm) the detector in fact records the light intensity of the light source scattered elastically by the particle, and since this is generally several orders of magnitude larger than the fluorescence typically expected from a particle, the signal recorded at this detector (see trace 22 of FIG. 4) saturates and is of no material value in assessing the particle.

[0049] The xenon light sources are then recharged, which takes approximately 5 ms, before the sequence can be repeated. The time for recharging combined with the thermal limit of 125 flashes/second for the xenon light sources limits the number of particles that can be measured to approximately 125 particles per second. Any particles which pass through the laser beam while the xenon light sources are recharging are detected and counted, however no fluorescence measurements are made. Furthermore, because the par-

ticle moves approximately 500 μ m during each measurement cycle, the two xenon light sources and the first and second detectors may be arranged each in a plane below that of the laser beam to improve the efficiency of capture of the fluorescence light from the particle.

[0050] To reduce the occurrence of false positive results and to improve particle size measurement the particle shape is assessed through azimuthal distribution of scattered light around the axis of the light beam. For this, a quadrant photomultiplier tube detector is a feature of the apparatus. Elongated particles such as fibres or rod-shaped bacilli tend to align with their long axis parallel to the airflow axis. The scattering pattern from the particle is then characteristic of the shape of the particle and its alignment. This shape measurement allows the apparatus to differentiate between particles with similar fluorescence characteristics such as unburnt fuel droplets from that of *Bacillus globigii* spores: fuel droplets are reported as spherical, the spores are not. Now referring to FIG. 5, the response of the four photomultiplier tube channels enables characterisation and identification of a droplet 25 (spherical), a fibre 26 (where its vertical alignment leads to predominantly horizontal scattering), a flake-like particle 27, and an irregular shaped particle 28 (no specific geometry). The values recorded in each of the four channels enables computation of a single Asymmetry Factor (Af) for the particle, based on the root-mean-square of the variation in intensity about the laser beam axis (azimuth). Af is scaled to give 0 for a perfect sphere and 100 for a long fibrous particle. In practice, because of limitations in signal-to-noise in the four channels, spherical particles do not give 0 but normally a small value, typically <5.

[0051] Assessment of particle size using the embodiment of FIG. 1 is performed by combining the forward light scattered response recorded at the quadrant photomultiplier tube detector with the side light scattered response recorded at the second detector which provides for a more accurate size measurement than either response alone. The response curve resulting from the output of the quadrant photomultiplier tube taken alone is not monotonic but shows Mie oscillations at various points, which means that conversion of the output to a particle size value cannot be done without ambiguity. Similarly, the scatter signal output recorded at the second detector is proportional to the particle size but not monotonically. It too has Mie oscillations in the response curve, but these occur at different particle sizes to those in the quadrant photomultiplier tube response curves. Thus by combining the output of the two detectors the unwanted affects of the ambiguities in sizing caused by the Mie oscillations can be minimised (see FIG. 8).

[0052] Now having regard to FIG. 6, the arrangement of the components (laser 29, xenon light sources 30, the two detectors 31, and the two concave glass minors 32 containing central apertures) in one embodiment of the apparatus is essentially symmetrical, in a horizontal plane, about the laser beam axis 33 with one minor, one detector and one xenon light source on each side of the laser beam 33. In this embodiment the separation of the minor surfaces at their common axis is $\frac{1}{2} \times$ focal length of the minors so that light from the detection zone of the apparatus is reflected from one minor and back through the aperture in the second mirror and onto the detector, as illustrated in FIG. 6. The angular position of the xenon light sources in the horizontal plane is unimportant, but is governed by mechanical considerations of fitting the xenon optics into the space provided ensuring that the beam

of light from each xenon light source exits from the zone, i.e. the space between the mirrors, without the light beam being incident on either mirror. A mirror focal length of 25 mm is utilised in this embodiment of the apparatus to ensure that the minor separation is sufficient to allow the two xenon sources and the laser optics to all fit in the horizontal plane, and illuminate the zone of the apparatus. The mirrors in this embodiment are of a longer focal length than the mirrors in the apparatus disclosed in Kaye P. H. et al. Proceedings SPIE European Symposium Optics/Photonics in Security and Defence Bruges, September 2005, 59900 N1-N12 (focal length of 17.5 mm) in which the two xenon light sources and the laser are in the same vertical plane, which is not substantially orthogonal to the direction of the airflow, and thus the mirrors are capable of being closer together without interfering with the light beams. The result of this is that light collection by each mirror in this embodiment of the invention is slightly less than that of the apparatus in the cited prior art, however this disadvantage is more than offset by the advantage of having the two xenon light sources both in the horizontal plane, wherein they may be focussed more tightly onto the specific volume of the fluid flow.

[0053] Now having regard to FIG. 7, it is not essential to have a detector either side of the laser beam 33, as both detectors 31 may be present on a single side of the laser beam 33 as shown. Here the mirrors 32 are separated by $3 \times$ focal length of the mirrors. Light from a particle scattered or emitted towards the right hand mirror is reflected back through the zone onto the left hand mirror and then reflected back through the aperture in the right hand mirror. Light scattered or emitted towards the left mirror is also reflected through the aperture in the right hand mirror. The collected light can then impinge on a dichroic mirror at 45° to reflect light in one wavelength band (300 to 400 nm) to one detector whilst light in a second wavelength band (400 to 600 nm) is transmitted to the second detector.

[0054] Now having regard to FIG. 8, the theoretical light flux responses (y axis) at the quadrant detector 34 (forward scattered light) and the second photomultiplier tube detector 35 (back/side scattered light) were calculated for increasing particle sizes (x axis) using Mie theory, assuming all particles to be spherical. The responses 34 and 35 show that scatter signals measured by these sensors can be used to gain an impression of particle size. However, both curves show undulations (Mie oscillations) which means that sizing of a particle based on a single detector response can be ambiguous (i.e. a horizontal line may intersect the line at more than one point, and thus more than one particle size is possible). To minimise the problem the responses 34 and 35 were combined such that response 34 is dominant for particle sizes up to 3 μ m and response 35, the weaker of the two but less prone to Mie oscillations, is dominant for larger particle sizes. To achieve this response 35 was squared to increase its magnitude with respect to response 34, and further mathematically modified to improve the match between the two signals. This entailed changing the exponent of response 35 from 2 to 2.1, and dividing the result by 1000. Response 36 shows the two signals combined. The plot is actually the square root of the combination, i.e. the square root of Response 34 plus Response $35^{2.1}/1000$. The square root allows a good fit of a second order rather than a third order polynomial to response 36, which exhibits much smaller Mie oscillations. The poly-

nomial equation $y=16.779x^2+95.563x-11.966$ is then used in software to convert the combined scatter signals into a single particle size approximation.

[0055] Now having regard to FIG. 9, a cross section of one embodiment of the apparatus along the laser beam axis shows features for enabling an aerosol to be flowed to the detection zone of the apparatus, and thereby illuminated with a laser beam 43. Ambient air is drawn into aerosol inlet 37 by the air pump at a rate of 2,115 ml/min. Some 211 ml of the airflow (10%) continues to flow down the central sample delivery tube 38, of 1.65 mm internal diameter. The remainder of the airflow is extracted through a side tube 39 and is reintroduced at another side tube 40 as a particle-free sheath flow after passing through a HEPA filter 41. The two airflows join as a laminar flow at the end of the sample delivery tube and are focused to a narrower total diameter of 1 mm by a tapered inlet nozzle 42. The sample flow is constrained to a vertical column of ~ 0.6 mm diameter as it passes through the laser beam 43 5 mm below the tip of nozzle 42. The air is then vented through Vent tube 44.

[0056] The laser beam 43 is provided by a continuous wave 12 mW diode laser module 45 at 635 nm wavelength. The output beam from the laser is linearly polarised and must be rendered circularly polarised in order to ensure that the particle scattering pattern received by the quadrant photomultiplier detector 47 is not affected by polarisation effects which could impair characterisation of particle shape from the detector data. The beam then passes through a cylindrical lens 46 of 75 mm focal length such that, at the intersection of the beam with the sample airflow, the beam is approximately 150 μ m deep. This intersection, referred to as the specific volume is disc shaped of dimensions 0.6 mm diameter and 150 μ m thick. A particle in this specific volume will scatter light to the quadrant PMT detector 47 which is positioned such that the centre of the quadrant lies on the beam axis and the lines separating the quadrants being at 45° to the vertical.

1. An apparatus for detection of a fluid borne particle comprising:

- i. a pair of coaxially opposed concave reflective surfaces about a zone whereby flow means are provided for delivering a fluid flow comprising the fluid borne particle through the zone;
- ii. a laser arranged to illuminate the fluid flow in the zone;
- iii. a first and second detector wherein the first detector is arranged to detect scattered and/or emitted light of a first wavelength band emanating from the zone and the second detector is arranged to detect scattered and/or emitted light of a second wavelength band emanating from the zone;
- iv. a first and second light source wherein the first source is arranged to illuminate the zone with light of a third wavelength band and the second source is arranged to illuminate the zone with light of a fourth wavelength band

whereby the laser and the first and second light source are each arranged in a plane substantially orthogonal to the direction of the fluid flow provided for by the flow means.

2. An apparatus according to claim 1 wherein the two detectors are each arranged in a plane substantially orthogonal to the direction of the fluid flow provided for by the flow means.

3. An apparatus according to claim 1 wherein the laser and the first and second light source are substantially arranged in

a single plane substantially orthogonal to the direction of the fluid flow provided for by the flow means.

4. An apparatus according to claim **3** wherein the two detectors are substantially arranged in the same plane as the laser and the first and second light source.

5. An apparatus according to claim **1** wherein the third wavelength band is shorter in wavelength than the first wavelength band and the second wavelength band.

6. An apparatus according to claim **1** further comprising a third detector for detecting forward scattered light as a result of illuminating the particle by the laser and/or the first or second light source.

7. An apparatus according to claim **6** wherein the third detector is arranged in the same plane as the laser and the first and second light sources.

8. An apparatus according to claim **1** wherein the first wavelength band is 300 to 400 nm.

9. An apparatus according to claim **1** wherein the second wavelength band is 420 to 600 nm.

10. An apparatus according to claim **1** wherein the third wavelength band is 280 nm and the fourth wavelength band is 370 nm.

11. An apparatus according to claim **1** wherein the third detector is a quadrant photomultiplier tube detector.

12. An apparatus according to claim **6** further comprising feedback means between the second detector and the third detector, wherein the second detector is capable of detecting back or side scattered light such that the feedback means provides for accurate measurement and identification of particle size.

13. A method for detection of a fluid borne particle comprising sequentially illuminating a fluid flow with a laser, a first light source and a second light source, whereby the laser illuminates a specific volume of the fluid flow and records the presence of a fluid borne particle and the first light source and the second light source illuminate the specific volume to elicit fluorescent signals from the particle which are detected by suitable means for light detection, whereby the laser, first light source and second light source are arranged in a plane substantially orthogonal to the fluid flow.

14. Use of the apparatus according to claim **1** for detecting fluid borne particles.

* * * * *