

# Toward Terabit-per-Second Capacities Over Multimode Fiber Links Using SCM/WDM Techniques

E. J. Tyler, P. Kourtessis, M. Webster, *Member, IEEE*, E. Rochart, T. Quinlan, S. E. M. Dudley, S. D. Walker, R. V. Penty, *Member, IEEE*, and I. H. White, *Senior Member, IEEE*

*Invited Paper*

**Abstract**—This paper outlines the progress made on the use of subcarrier multiplexing (SCM) for high-speed datacommunications links over multimode fiber. Results include the demonstration of penalty-free transmission of 2.5 Gb/s data over worst case multimode fiber (MMF). A complete link demonstration of an SCM transmission system is reported, based on a quadrature phase-shift keying modulator and demodulator capable of a record 5.1 Gb/s per subcarrier data transmission. Superior performance compared with conventional baseband modulation techniques is shown. It is also demonstrated that when SCM is combined with dense wavelength-division multiplexing (WDM), aggregate data capacity of 200 Gb/s is feasible. Preliminary results demonstrate the possibility of 20-GHz WDM channel spacings, which if scaled show the potential for 1-Tb/s aggregate rates with a bandwidth-length product of 3 Tb/s·km.

**Index Terms**—Multimode fiber, optical fiber communications, optical modulation, subcarrier multiplexing, wavelength-division multiplexing.

## I. INTRODUCTION

THE rapidly growing demands on the bandwidth of computer backbone links have made it necessary to increase the transmission capacity in local-area networks beyond 1 Gb/s. The majority of within-building legacy links employ multimode fiber (MMF) with typical link lengths around 300 m. Therefore, there is much interest in achieving high-speed data transmission on the currently installed MMF links.

Previous work (now standardized) has included transmission at the gigabit Ethernet rate of 1.25 Gb/s over 550 m of MMF with long-wavelength (1300 nm) laser sources, and over 275 m at 850-nm sources [1]. These link lengths are limited by the specified bandwidth of the installed base MMF. This is

160 MHz·km at a wavelength of 850 nm and 500 MHz·km at 1300 nm for the 62.5- $\mu$ m core diameter fiber type dominant in the United States and Europe. At data rates beyond 1 Gb/s, the link lengths that can be supported become significantly reduced using conventional techniques. For example, at 10-Gb/s data rates, transmission link lengths are restricted to less than 60 m [2]. However, as the bandwidth demand of local-area networks continues to rise, ever-faster fiber-optic links will be required in the backbones that aggregate the traffic of many users.

Therefore, in responding to market demand for 10-Gb/s backbone links over installed base MMF, alternative approaches are currently being adopted. In order to maintain the use of the large installed base of multimode fiber, low-cost coarse wavelength-division multiplexing (WDM) modules have been developed [3]. There are many variants but [3] describes a four-channel transceiver, designed to operate with MMF, with each channel operating at 3.125 Gbd to achieve an aggregate data rate 10 Gb/s (12.5 Gbd with 8 B/10 B coding). Channel wavelength spacings of 25 nm allow the use of uncooled distributed feedback (DFB) laser sources to support transmission over 300-m MMF. Additionally, new higher bandwidth multimode fiber has been developed that can support link lengths of up to 2 km at 10 Gb/s with low-cost 850-nm optoelectronic components [4].

A number of other groups have recently focused on approaches that, together with the above, can be used to further increase the bandwidth-distance product of MMF links by reducing the intersymbol interference caused by differential mode delay (DMD). These include using spatially resolved receivers, which spatially detect different signals at the output from the MMF and subsequently recombine them with appropriate electrical amplitude and phase weighting to reduce the effects of DMD [5]. Another approach uses electrical equalization in the receiver, based on a nonlinear adaptive decision feedback equalizer, to combat the DMD and increase the transmission distance toward loss-limited lengths [6].

Each of the above techniques makes use of the baseband bandwidth or, in the case of equalization techniques, attempts to extend the equivalent baseband bandwidth of the MMF for data transmission. However, unlike in single-mode fiber, the frequency response of MMF does not decay steadily after the 3-dB point, which defines the low-pass bandwidth of the fiber. Instead

Manuscript received May 14, 2003; revised September 23, 2003. This work was supported by the UK Engineering and Physical Sciences Research Council OSI program and under the PHOTON project.

E. J. Tyler was with the University of Bristol, U.K. She is now with BAE Systems, Advanced Technology Centre, BS34 7QW Bristol, U.K.

P. Kourtessis, E. Rochart, T. Quinlan, S. E. M. Dudley, and S. D. Walker are with the Optical Systems Research Group, Department of Electrical and Systems Engineering, University of Essex, CO4 3SQ Colchester, U.K.

M. Webster, R. V. Penty, and I. H. White are with the Department of Engineering, University of Cambridge, Cambridge CB2 1PZ, U.K. (e-mail: rvp11@eng.cam.ac.uk).

Digital Object Identifier 10.1109/JLT.2003.819802

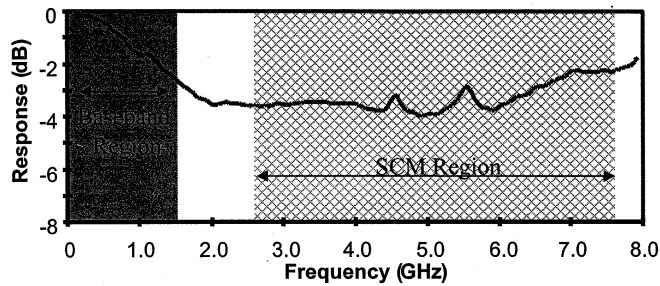

Fig. 1. Frequency response of a 300-m length of worst case 62.5- $\mu$ m diameter MMF at a wavelength of 1300 nm showing baseband (shaded area) and passband (hatched area) regions.

there are large regions of relatively flat response at frequency beyond the low-pass bandwidth, hereafter referred to as passband regions, which have the potential for supporting additional data channels beyond the 3-dB bandwidth generated by subcarrier multiplexing (SCM) [7]. SCM was first demonstrated as a technique to allow substantially enhanced transmission bandwidths in MMF by Raddatz *et al.* in 1998 [8]. Since then, the transmission of 1-Gb/s binary phase-shift keying (BPSK) data over 1 km of MMF using a single subcarrier at 2.5 GHz was demonstrated by Woodward *et al.* [9].

In this paper, progress on SCM as a technique for allowing even higher data rate transmission over installed grade multimode fiber is reviewed [10], [11]. In particular, the combination of both quadrature SCM and high-density WDM techniques is shown to offer the potential of ultrahigh data rates over conventional MMF links [12]. In addition, a preliminary experiment is described that demonstrates the possibility of 20-GHz WDM channel spacings that, if scaled, show the possibility of 1-Tb/s aggregate rates with a bandwidth-length product of 3 Tb/s·km.

## II. SUBCARRIER MULTIPLEXING FOR INCREASING USABLE MMF BANDWIDTH

Subcarrier multiplexing allows access to previously ignored regions of the MMF frequency response and thus can make more efficient use of the fiber bandwidth as a whole. Fig. 1 shows the frequency response of a 300-m length of 62.5- $\mu$ m MMF at a wavelength of 1300 nm. This shows the modal dispersion-limited baseband region and the flat passband region where extra channels can be transmitted. Unlike in SMF, where the frequency response falls steadily toward zero, the frequency response of multimode fiber contains high-frequency components. Since the impulse response of MMF consists of a number of impulse functions that correspond to the individual modes separated in time, the Fourier transform or frequency response must contain nonzero high-frequency components. This behavior can be understood by considering the time-domain response of the fiber to a short input pulse. Such a pulse will break up into a series of pulses as different modes propagate through the fiber at different speeds. This will result in a series of pulses of various amplitudes at the output depending on the differential mode delay and mode coupling properties of the fiber. A Fourier transform of the resulting pulse train provides the frequency response, which exhibits a strong falloff near dc as the slowest and fastest modes interfere at the receiver.

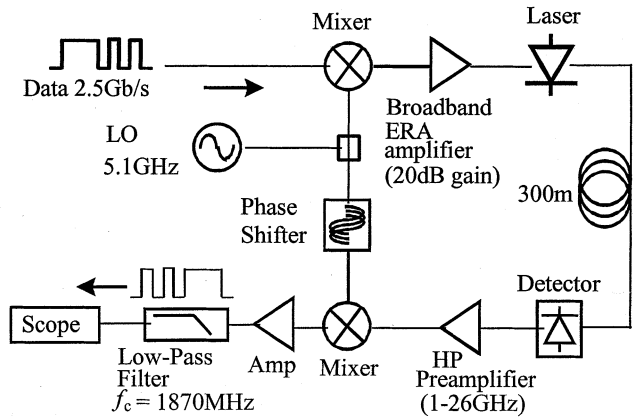

Fig. 2. Experimental setup used for transmission of a single 2.5-Gb/s subcarrier channel.

The 3-dB point gives the baseband bandwidth of the fiber. Above the 3-dB bandwidth, the response is mainly determined by the dispersion between the higher order modes. Therefore, at higher frequencies, there are many delayed pulses that can interfere with one another corresponding to transmission of the large number of higher order modes that have similar propagation times. This leads to a smoothing effect in the frequency response at such frequencies, with some background loss, giving rise to a passband region suitable for data transmission.

By modulating a nonreturn-to-zero (NRZ) baseband stream onto a high-frequency subcarrier using digital modulation techniques, such as frequency- or phase-shift keying, it is possible to transmit additional channels in these passband regions. SCM can be used as a technique on its own, or combined with any of the baseband techniques previously mentioned, to further increase the available transmission bandwidth. This technique has been widely reported in single-mode fiber links for distribution of cable TV to subscribers in North America [7].

To initially demonstrate the benefit of the SCM technique for increasing MMF link capacities, experiments have been carried out to compare the transmission performance at 2.5 Gb/s over MMF, with conventional baseband modulation [10]. Fig. 2 shows a typical setup for an SCM MMF link demonstration. The subcarrier channel was implemented by modulating a 2.5-Gb/s  $2^7-1$  PRBS onto a 5.1 GHz subcarrier using a binary phase-shift keying (BPSK) modulation scheme via a simple double balanced microwave mixer. A  $2^7-1$  pseudorandom bit sequence (PRBS) was chosen to simulate the types of data patterns that occur in optical data communications systems. An example of this is the IEEE gigabit Ethernet standard, which employs 8B10B coding to ensure short pattern lengths, mainly to reduce the effect of baseline wander at the receiver [1], [13]. Indeed, a  $2^7-1$  PRBS is a more severe test in terms of frequency range than this form of coding.

The subcarrier channel was then used to directly modulate a 1300-nm Fabry-Perot laser. After transmission over 300 m of MMF, the signal is detected using a high-speed photodiode. A simple BPSK demodulation scheme was used in which the same synthesizer and an identical mixer as used for upconversion are used to recover the 2.5-Gb/s data signal. The received eye diagrams after transmission using both SCM and baseband

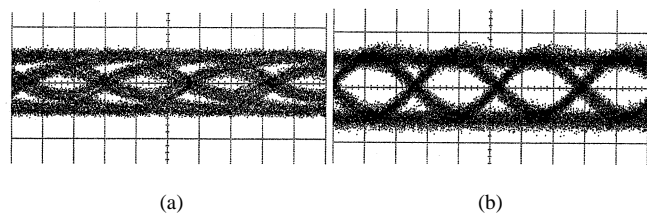

Fig. 3. Recovered eye diagrams of 2.5-Gb/s channels after transmission over 300-m MMF. (a) Baseband and (b) SCM channel at subcarrier frequency of 5.1 GHz. (150 ps/div).

modulation techniques over the 300-m length of 62.5- $\mu\text{m}$  MMF are shown in Fig. 3. It can clearly be seen that the received 2.5-Gb/s SCM signal is of significantly higher quality than baseband modulation at the same data rate resulting from the low bandwidth of the baseband region compared with the flat passband region.

Since the form of the passband response results from the interference of the MMF modes at the receiver, it might be thought possible to vary the shape of this response by varying the environmental conditions of the fiber, thus adversely affecting the received SCM signal. In order to test this possibility, we undertook short-term mechanical stressing of the fiber by shaking and medium-term tests by observing the system stability over a period of several days and by varying the temperature of the experiment by approximately 10 °C. In all of these cases, the quality of the received SCM channel was stable with error-free operation at all times.

### III. OVERCOMING PASSBAND LOSS

Fig. 1 shows a passband loss of  $\sim 3.5$  dB<sub>O</sub>. Measurements over a number of MMF samples show that the passband loss varies in the range 3–7 dB<sub>O</sub>. Since optical data links, such as those specified for gigabit Ethernet or other datacommunications standards, have very tight power budgets, with little or no unallocated power margin, it is important that SCM transmission in the passband regions does not result in additional power penalties compared with baseband transmission [13] that this loss would imply. The use of SCM, however, does allow one to benefit from the ability of coherent/heterodyne detectors to provide coherent RF gain. This allows the potential for the additional passband fiber losses associated with SCM transmission over MMF to be compensated for [11].

To demonstrate this potential, transmission penalty measurements have been carried out in which 625-Mb/s data signals have been transmitted over a 500-m MMF link using baseband modulation and comparing this with the SCM approach. The modest speed of 625 Mb/s was used to allow a true comparison of the receiver sensitivities for SCM and baseband NRZ modulation, and neither modulation scheme suffers from intersymbol interference penalties at this data rate. Fig. 4 shows the bit error rate (BER) curves measured for the baseband and SCM channels at the end of the 500-m link. It can be seen that for a BER of  $10^{-9}$ , there is a 3.9-dB improvement in receiver sensitivity for the SCM case compared with the baseband performance. This improvement is sufficient to compensate for the additional 4.3-dB passband loss in the fiber compared with baseband, as shown in Table I. It can therefore be seen that the coherence of

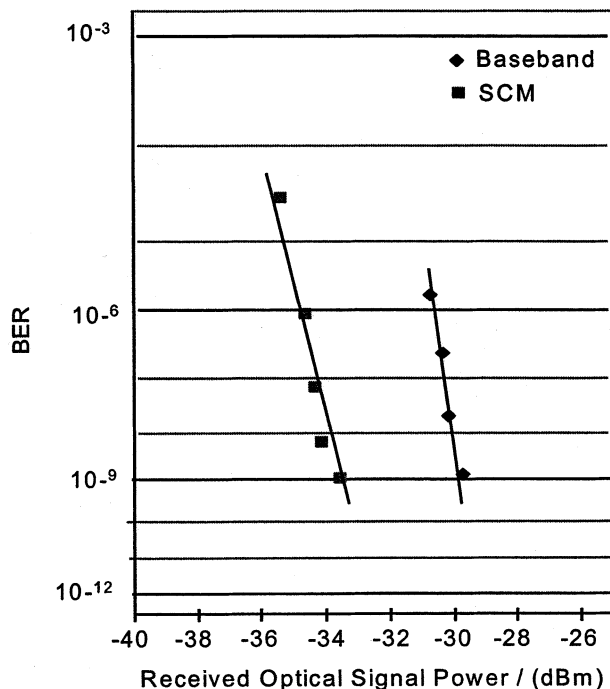

Fig. 4. BER characteristics showing received optical signal powers for 625-Mb/s SCM and baseband transmission over a 500-m MMF link.

the BPSK scheme used in the generation of the SCM channel results in an improvement in receiver sensitivity, thus allowing penalty-free link operation.

### IV. INCREASING SPECTRAL EFFICIENCY—QPSK SCM CHANNELS

The previous sections have shown that an enhancement in the capacity of MMF links can be achieved over conventional baseband techniques by employing SCM schemes. However, all of the above work makes use of BPSK modulation, as it is easy to achieve multigigabit SCM channels with this modulation format using readily available microwave mixers. However, this modulation format is relatively spectrally inefficient, and it is very attractive to consider alternative modulation formats, such as quadrature phase-shift keying (QPSK) and quadrature amplitude modulation (QAM), to improve the spectral efficiency of the transmission scheme. As we show later, this is particularly important for dense WDM (DWDM) transmission, but it also has advantages in single wavelength systems, as it allows more robust utilization of the MMF passband response.

However, as is well known, the use of these more advanced modulation formats, while being more spectrally efficient than two-level signals, does require a larger signal-to-noise ratio (SNR) to allow a given received sensitivity [14]. The use of QPSK, sometimes known as 4-QAM, requires double the SNR of BPSK for the same symbol rate. However, QPSK carries two bits per symbol compared to one bit for BPSK. Hence the required SNR per bit per second is identical for the two modulation formats while QPSK has the better spectral efficiency.

While spectrally efficient modulation techniques, such as QPSK and QAM, have been widely deployed in mobile

TABLE I  
COMPARISON OF BASEBAND AND SCM CHANNEL TRANSMISSION PENALTY. THE NET POWER MARGIN IS RELATIVE TO THE BASEBAND LINK

	Tx Signal Power (dBm)	Fibre Loss (dB <sub>0</sub> )	Rx Sensitivity (dBm)	Net Power Margin (dB <sub>0</sub> )
Baseband	-27.27	2.42	-29.69	0
SCM	-27.17	6.74	-33.57	-0.335

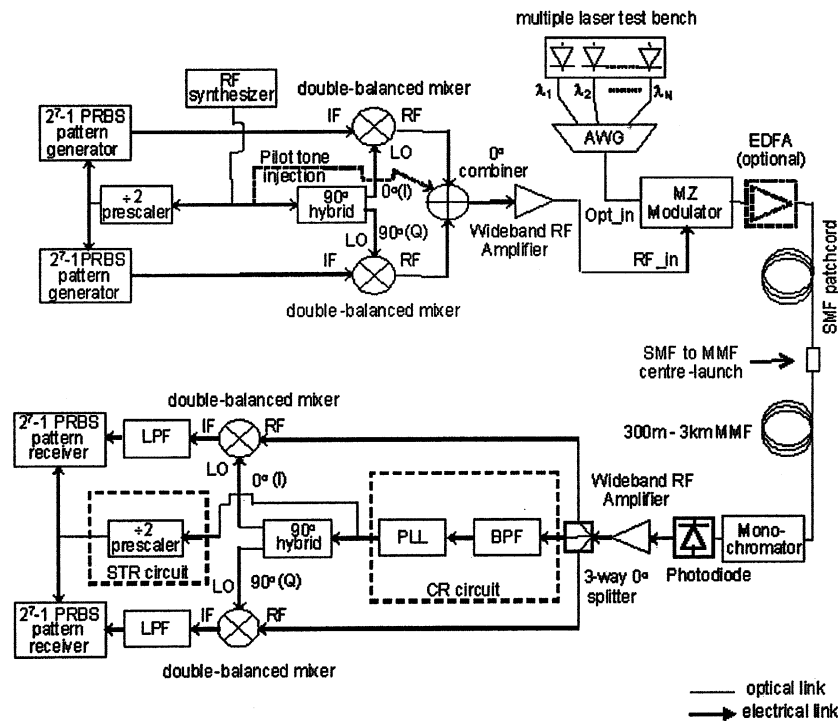

Fig. 5. Experimental setup for the transmission of a 5.1-Gb/s I&Q signal over MMF.

telephony and wireless local-area network systems, the modulators have been relatively narrow-band with data rates of only 10 s Mb/s being readily available. Since commercial broadband QPSK or QAM modulators are not available, a 5.1-Gb/s QPSK modulator has been constructed from discrete components [15]. Since, as is well known, a QPSK modem is characterized by two orthogonal BPSK channels, which can be detected separately, it can be implemented in practice by two synchronous pulse streams, modulating the cosine and sine functions of a subcarrier signal. The summation of the orthogonal BPSK waveforms will correspond to the composite QPSK or equivalent inphase and quadrature (I&Q) signal at twice the symbol rate with four possible phase states,  $0^\circ$ ,  $\pm 90^\circ$ , or  $180^\circ$ .

The following experiment describes the complete implementation of a 5.1-Gb/s throughput SCM system for standard within-building multimode fiber applications. I&Q 2.55-Gb/s channels were combined in a novel zero-latency subcarrier and data synchronization scheme, to provide straightforward carrier and symbol timing recovery circuits. The I&Q transmission system is illustrated in Fig. 5. In the modulator, the pattern generators produce two  $2^7-1$  PRBSs at a bit rate of 2.55 Gb/s each.

The subcarrier frequency at 5.1 GHz was split into a  $90^\circ$  hybrid to provide the inphase and quadrature signals, modulated into two double-balanced mixers by the data sequences. Therefore, combination of the quadrature 2.55-Gb/s data channels on a 5.1-GHz subcarrier allowed the transmission of an aggregate of 5.1 Gb/s over the MMF optical link. In the modulator, the subcarrier frequency was reinjected at the point where the quadrature signals were combined, to provide a pilot tone in the transmitted signal spectrum for subcarrier extraction. Also, the transmitted data sequences were synchronized to half the subcarrier frequency, through a divide-by-two prescaler. After broadband amplification, the composite signal was passed to a 10-GHz-bandwidth Mach-Zehnder (MZ) modulator, used to externally modulate a laser source operating at 1550 nm. In this initial experiment, only one of the sources in the laser array of Fig. 5 was used and hence the arrayed waveguide grating (AWG) and monochromator devices were omitted. The single-mode fiber MZ output was then launched into MMF spans, ranging from 300 m to 3 km. After transmission through the fiber, the signal was detected using an MMF-pigtailed 12-GHz-bandwidth PIN photodiode and, after further amplification, passed to the receiver subsystem.

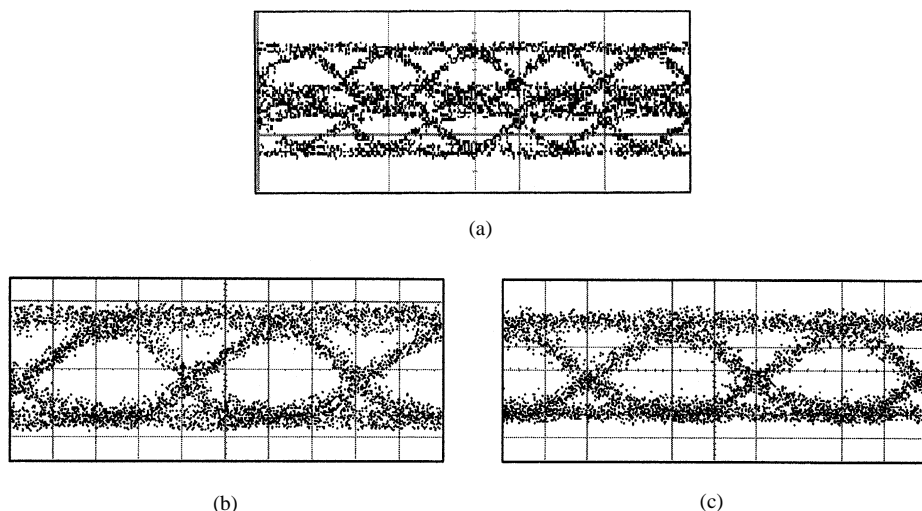

Fig. 6. Comparison of received eye diagrams at 1550.9 nm after 300 m of 62.5- $\mu$ m MMF for (a) 2.5-Gb/s conventional baseband transmission, 100 ps/div, 50 mV/div and (b) subcarrier transmission, 1 channel, (c) Q-channel, 200 ps/div, 30 mV/div.

One of the major issues associated with the detection of the SCM channel is the extraction of the carrier frequency and the subsequent demodulation of the signal. This has been studied extensively in coherent detection systems [16]. However, the receiver required for our system is much more complicated, as we used a QPSK modulation format. In our experiment, the receiver consisted of a three-way splitter, which divided the signal between the 5.1-GHz clock recovery circuit and the two arms of the I&Q demodulator. The phase-locked loop (PLL) output provided the conventional quadrature reference for baseband down-conversion of the subcarrier signals, and also direct zero-latency synchronization of the data sequences by means of a further divide-by-two prescaler. By this means, acquisition of the optical signal by the receiver subsystem guaranteed synchronization of the data. The demodulated I&Q signals were then finally passed via 1.87-GHz 3 dB-bandwidth low-pass filters to two data receivers, which were synchronized by the carrier-locked prescaler output signal.

Fig. 6 shows the recovered eye diagrams after transmission of the baseband signal as well as the composite 5.1-Gb/s I&Q signal over 300 m of a worst case 62.5- $\mu$ m core-diameter MMF. It can be seen from this figure that it was not possible to transmit 2.55 Gb/s in the baseband. In contrast, good quality eyes are observed for both the inphase and quadrature channels. Each of the recovered channels in the 5.1-Gb/s system is comparable in performance to the transmission of a single 2.5 Gb/s at a 5.1-GHz carrier over 62.5- $\mu$ m MMF, as presented in Section II. This suggests that this method of I&Q generation will be successful in all standard types of MMF while achieving at least twice the transmission capacity demonstrated with binary signaling.

BER measurements have demonstrated an error rate of better than  $10^{-12}$  for subcarriers modulated in quadrature, with a fixed phase error tolerance between the unmodulated and recovered subcarriers of up to around 40°. The observed probability of error for each transmitted channel with phase is shown in Fig. 7. It should also be pointed out that the FM-capture effect present within most PLLs provides strong attenuation of unwanted data sidebands, should they appear within the loop passband. This subtle effect reinforces the low-jitter nature of the PLL output [15]. Much longer PRBS lengths can be accommodated by the

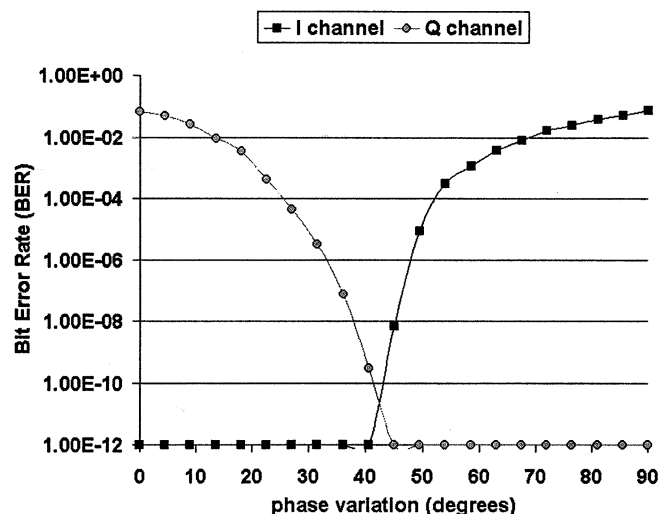

Fig. 7. Bit error rate versus phase variation between the I and Q channels.

implemented PLL, as even data sidebands as close-in to the carrier as 1 Hz are still strongly suppressed. This indicates that the described technique is useful for a wide range of data formats.

#### V. COMBINATION OF SCM WITH WDM FOR INCREASED MMF LINK CAPACITY

It is also possible to increase the total transmission capacity of MMF systems by making use of the wavelength dimension. This has been demonstrated in low-cost coarse WDM (CWDM) links as mentioned previously [3]. It is possible to combine the performance advantages of SCM over MMF with dense WDM to achieve very high aggregate bit rates. The following experiment serves the purpose of demonstrating further enhancement in the already significant 5.1-Gb/s capacity offered by the existing I&Q modem system. For that purpose, the subcarrier channels were modulated simultaneously onto 100-GHz spaced wavelengths over the ITU grid's C-band. The combination of 40-channel dense-WDM and SCM transmission over 3 km of standard 50- $\mu$ m MMF indicates a potential throughput of 204 Gb/s [17].

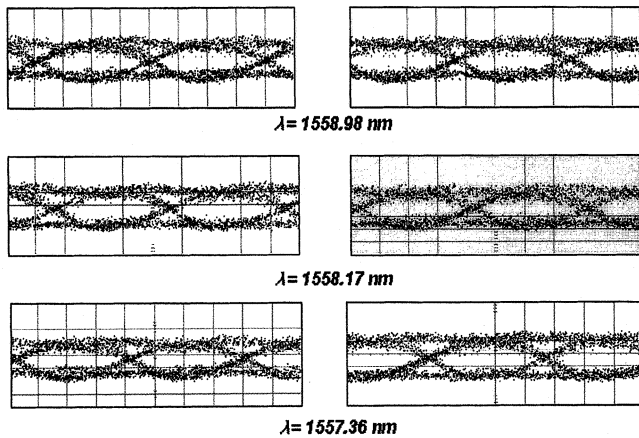

Fig. 8. Representative recovered inphase I (left) and Q (right) eye diagrams at adjacent wavelengths of 1557.36, 1558.17, and 1558.98 nm over 3 km of MMF (100 ps/div, 30 mV/div).

The setup used follows the exact configuration of Fig. 5. The MZ modulator in this case controls simultaneously the intensities of ten representative frequency-stabilized lasers and additional wavelength-tunable channels. These channels on the ITU grid, each carrying 5.1-Gb/s data on a 5.1-GHz subcarrier, were combined using a commercially available 40-channel AWG on a 100-GHz (0.8 nm) wavelength grid and transmitted over 3 km of 50- $\mu\text{m}$  core-diameter MMF. By this means, all 40 channels on the ITU grid can be used for data transfer.

It should be noted that in a practical datacommunications system, it is highly unlikely that, for reasons of cost, high-quality externally modulated sources would be used. For instance, [3] employs directly modulated DFB lasers with poor side-mode suppression ratio. Channel spacings are kept much wider than in our demonstration to avoid the penalties arising from crosstalk that would arise if 100-GHz channel spacing were employed. However, the purpose of our experiments is to show the *potential* capacity of MMF systems should such cost restrictions be removed in the future.

At the receiver end, each of the 40 possible channels were wavelength selected using an electronically tuned monochromator, the output of which was passed to an MMF-pigtailed 12-GHz-bandwidth PIN photodiode and, after further amplification, passed to the demodulator subsystem. Each of the I and Q channels is therefore wavelength demultiplexed and electronically demodulated.

A set of experiments have been carried out where in each case, ten frequency-stabilized and tunable laser sources over the C-band ITU grid with 100-GHz spacing were combined simultaneously in the AWG. In the course of our experiments, correct operation was verified over the complete C-band ITU-grid, paying particular attention to adjacent-channel interference effects. Fig. 8 shows representative recovered inphase and quadrature eye diagrams for adjacent wavelengths at 1557.36, 1558.17, and 1558.98 nm. Adjacent channel interference effects show no discernible penalty. Clearly, with a fully populated 40-laser array, the experimental link would offer 204-Gb/s data throughput over 3 km.

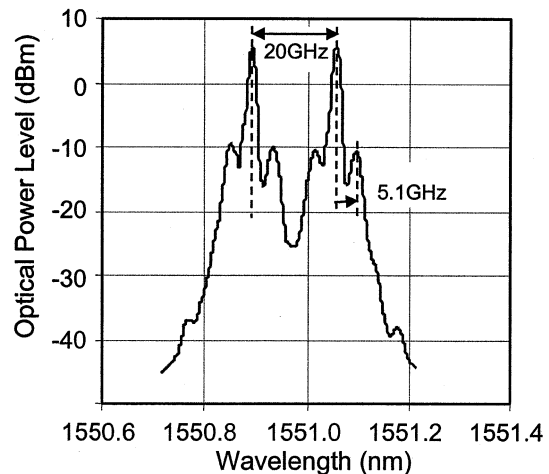

Fig. 9. Optical spectrum of  $2 \times 5.1$  Gb/s SCM channels separated by 20 GHz showing SCM sideband at  $\pm 5.1$  GHz.

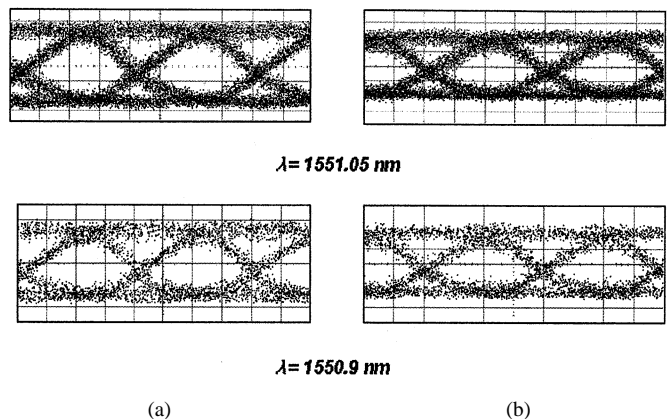

Fig. 10. Representative recovered (a) I and (b) Q eye diagrams at wavelengths of 1550.9 and 1551.05 nm over 3 km of MMF.

## VI. FEASIBILITY OF 1-Tb/s LINK CAPACITY

Finally, in order to assess how closely WDM-SCM channels could be spaced with the 5.1-Gb/s QPSK signal, a high-performance free-space WDM multiplexer, loaned by Essex Corporation, has been used.<sup>1</sup> The spectrum of each transmitted wavelength channel, as described in the previous section, exhibits modulation sidebands centered at 5.1 GHz on either side of the optical carrier. Since each transmitted channel therefore occupies a bandwidth of about 15.2 GHz, two wavelength channels with a spacing of 20 GHz have been combined as shown in Fig. 9. Detection of the quadrature signals in the system demodulator indicates that even for 20-GHz spaced optical carriers, subcarrier transmission demonstrates no discernible crosstalk between adjacent channels. Fig. 10 shows the recovered eye diagrams after simultaneous transmission over 3-km MMF on the adjacent wavelengths of 1550.9 and 1551.05 nm [13]. The successful transmission of both ten frequency-stabilized and tunable laser sources as described in the previous section and two selected individual wavelengths with 20-GHz spacing

<sup>1</sup><http://www.essex.com>.

within each 100-GHz passband of the AWG was demonstrated. While this demonstration leaves unanswered questions, particularly with respect to the possibility of excessive interference noise with a fully populated 200-wavelength grid, it does indicate a potential for 1.02-Tb/s data transmission up to 3 km of standard 50- $\mu$ m MMF, if 200  $\times$  5.1 Gb/s WDM/SCM channels within the C-band ITU-grid were used.

## VII. CONCLUSION

This paper has described the use of SCM for datacommunications applications over multimode fiber. SCM can be used to provide significantly enhanced bandwidth over bandlimited MMF transmission systems by making use of the MMF passband. It has been shown that successful extended range transmission over MMF can be achieved using subcarrier modulation, with the subcarrier channel demonstrating improved performance compared to conventional baseband transmission. This has been achieved by developing an I&Q modem with 5.1 Gb/s per subcarrier capacity and subsequently implementing this in a full MMF link test bed.

The coherent modulation/demodulation scheme used to generate the SCM channel has then been shown to be able to overcome the power penalty associated with the excess passband loss, allowing SCM sensitivities lower than the equivalent baseband case. This is important, as it shows the potential for penalty-free SCM link operation with capacities in excess of baseband modulation techniques. In addition, we have demonstrated a 40  $\times$  5.1 Gb/s WDM/SCM system over both 500 m of worst case 62.5  $\mu$ m multimode fiber and 3 km of 50- $\mu$ m MMF. Preliminary results demonstrate the possibility of 20-GHz WDM channel spacings, which, if scaled, show the possibility of 1-Tb/s aggregate rates with a bandwidth-length product of 3 Tb/s-km.

## ACKNOWLEDGMENT

The authors would like to thank Essex Corporation for the loan of the DWDM multiplexer. The authors are grateful to Agilent Technologies for supplying some of the lasers used in this paper.

## REFERENCES

- [1] *The Gigabit Ethernet Standard*, IEEE Standard 802.3z, 1998.
- [2] *The 10 Gigabit Ethernet Standard*, IEEE Standard 802.3ae, 2002.
- [3] L. A. Buckman, B. E. Lemoff, A. J. Schmit, R. P. Tella, and W. Gong, "Demonstration of a small form factor WWDM transceiver module for 10-Gb/s local area networks," *IEEE Photon. Technol. Lett.*, vol. 14, pp. 702–204, May 2002.
- [4] P. Pepeljugoski, D. Kuchta, Y. Kwark, P. Pleunis, and G. Kuyt, "15.6 Gb/s transmission over 1 km of next generation multimode fiber," *IEEE Photon. Technol. Lett.*, vol. 14, pp. 717–719, May 2002.
- [5] K. M. Patel and S. E. Ralph, "Enhanced multimode fiber link performance using a spatially resolved receiver," *IEEE Photon. Technol. Lett.*, vol. 14, pp. 393–395, Mar. 2002.
- [6] X. Zhao and F. S. Choa, "Demonstration of 10-Gb/s transmission over a 1.5 km long multimode fiber using equalization techniques," *IEEE Photon. Technol. Lett.*, vol. 14, no. 8, pp. 1187–1189, 2002.
- [7] T. E. Darcie, "Subcarrier multiplexing for lightwave networks and video distribution systems," *IEEE J. Select. Areas Commun.*, vol. 8, pp. 1240–1247, 1990.

- [8] L. Raddatz, I. H. White, D. G. Cunningham, M. C. Nowell, M. R. T. Tan, and S. Y. Wang, "High bandwidth data transmission in multimode fiber links using subcarrier multiplexing with VCSELs," *Electron. Lett.*, vol. 34, pp. 686–688, 1998.
- [9] T. K. Woodward, S. Hunsche, A. J. Ritger, and T. B. Stark, "1 Gb/s BPSK transmission at 850 nm over 1 km of 62.5  $\mu$ m core MMF using a single 2.5 GHz subcarrier," *IEEE Photon. Technol. Lett.*, vol. 11, pp. 382–384, 1999.
- [10] E. J. Tyler, M. Webster, R. V. Penty, I. H. White, S. Yu, and J. Rorison, "Subcarrier modulated transmission of 2.5 Gb/s over 300 m of 62.5 mm core diameter multimode fiber," *IEEE Photon. Technol. Lett.*, vol. 14, pp. 1743–1745, Dec. 2002.
- [11] E. J. Tyler, M. Webster, R. V. Penty, and I. H. White, "Penalty free subcarrier modulated multimode fiber links for datacomm applications beyond the bandwidth limit," *IEEE Photon. Technol. Lett.*, vol. 14, pp. 110–112, Jan. 2002.
- [12] P. Kourtessis, T. Quinlan, E. Rochat, S. D. Walker, M. Webster, I. H. White, and R. V. Penty, "0.6 Tb/s/km multimode fiber feasibility experiment using 40 channel DWDM over quadrature-subcarrier transmission," *Electron. Lett.*, vol. 38, no. 15, pp. 813–815, 2002.
- [13] D. G. Cunningham and W. Lane, *Gigabit Ethernet Networking*: MacMillan Publishing, 1999.
- [14] J. G. Proakis, *Digital Communications*, 4th ed, ser. Series in Electrical and Computer Engineering. New York: McGraw-Hill.
- [15] P. Kourtessis, S. Dudley, Y. T. Quinlan, S. D. Walker, E. J. Tyler, R. V. Penty, and I. H. White, "A complete 5 Gb/s throughput quadrature subcarrier system featuring zero-latency carrier and data synchronization," in *Optical Fiber Communications Conf. (OFC'2002)*, vol. 2, 2002, pp. 144–145, paper TuV1.
- [16] P. M. Hill, R. Olshansky, and M. Abdollahian, "Novel carrier and clock-recovery circuit for multigigabit/second lightwave systems," *IEEE Photon. Technol. Lett.*, vol. 5, pp. 96–98, 1993.
- [17] E. Rochat, P. Kourtessis, M. Webster, T. Quinlan, S. Dudley, S. D. Walker, R. V. Penty, M. C. Parker, and I. H. White, "Ultra-high capacity transmission over 3 km of legacy 50  $\mu$ m-multimode fiber using c-band HDWDM and quadrature-subcarrier multiplexing," presented at the 28th Eur. Conf. Optical Communications ECOC'2002, paper 8.2.2.

**E. J. Tyler**, photograph and biography not available at the time of publication.

**P. Kourtessis**, photograph and biography not available at the time of publication.

**M. Webster** (S'98–M'00), photograph and biography not available at the time of publication.

**E. Rochat**, photograph and biography not available at the time of publication.

**T. Quinlan**, photograph and biography not available at the time of publication.

**S. E. M. Dudley**, photograph and biography not available at the time of publication.

**S. D. Walker**, photograph and biography not available at the time of publication.

**R. V. Penty** (M'00), photograph and biography not available at the time of publication.

**I. H. White** (S'82–M'83–SM'00), photograph and biography not available at the time of publication.