

I am very grateful to my educational supervisors for their guidance and support during this period of research.

**Prof Ken Farrington,
Prof Cindy O'Malley and
Prof Robert Slater**

Abstract

Volume overload is a common feature in patients on haemodialysis (HD). This contributes significantly to the cardiovascular disease burden seen in these patients. Clinical assessments of the volume state are often inaccurate. Techniques such as interdialytic blood pressure, relative blood volume monitoring, bioimpedance are available to improve clinical effectiveness. However all these techniques exhibit significant shortcomings in their accuracy, reliability and applicability at the bed side. We evaluated the usefulness of a dual compartment monitoring technique using Continuous Segmental Bioimpedance Spectroscopy (CSBIS) and Relative Blood Volume (RBV) as a tool to assess hydration status and determine dry weight. We also sought to evaluate the role of Atrial Natriuretic Peptide (ANP) and B-type Natriuretic Peptide (BNP) as a volume marker in dialysis patients.

The Retrospective analysis of a historical cohort ($n = 376$, 55 Diabetic) showed a significant reduction in post-dialysis weights in the first three months of dialysis (72.5 to 70kg, $p < 0.027$) with a non-significant increase in weight between months 6-12. The use of anti-hypertensive agents reduced insignificantly in the first 3 months, increased marginally between months 3-6 and significantly increased over the subsequent 6 months. The residual urea clearance (KRU) fell and dialysis times increased. The cohort was very different to that dialysing at Tassin and showed a dissociation between weight reduction and BP control. This may relate to occult volume overload.

CSBIS-RBV monitoring in 9 patients with pulse ultrafiltration (pulse UF) showed distinct reproducible patterns relating to extra cellular fluid (ECF) and RBV rebound. An empirical Refill Ratio was then used to define the patterns of change and this was related to the state of their hydration. A value closer to unity was consistent with the attainment of best achievable target weight. The refill ratio fell significantly between the first (earlier) and third (last) rebound phase (1.97 ± 0.92 vs 1.32 ± 0.2).

CSBIS monitoring was then carried out in 31 subjects, whilst varying dialysate composition, temperature and patient posture to analyse the effects of these changes on the ECF trace and to ascertain whether any of these interventions can trigger a change in the slope of the ECF trace distinct to that caused by UF. Only, isovolemic HD caused a change in both RBV and ECF in some patients that was explained by volume re-distribution due to gravitational shifts, poor vascular reactivity, sodium gradient between plasma and dialysate and the use of vasodilating antihypertensive agents. This has not been described previously. These will need to be explored further. The study did demonstrate a significant lack of comparability of absolute values of R_{ECF} between dialysis sessions even in the same patient. This too has not been described previously. This is likely to be due to subtle changes in fluid distribution between compartments. Therefore a relative changes must be studied. This sensitivity to subtle changes may increase the usefulness of the technique for ECF tracking through dialysis.

The potential of dual compartment monitoring to track volume changes in real time was further explored in 29 patients of whom 21 achieved weight reductions and were able to be restudied. The Refill Ratio decreased significantly in the 21 patients who had their dry weights reduced by 0.95 ± 1.13 kg (1.41 ± 0.25 vs 1.25 ± 0.31). Blood pressure changes did not reach statistical significance. The technique was then used to examine differences in vascular refill between a 36°C and isothermic dialysis session in 20 stable prevalent patients. Pulse UF was carried out in both these sessions. There were no significant differences in Refill Ratios, energy removed and blood pressure response between the two sessions. The core temperature (CT) of these patients was close to 36°C and administering isothermic HD did not confer any additional benefit.

Mean BNP levels in 12 patients during isovolemic HD and HD with UF did not relate to volume

changes. ANP concentrations fell during a dialysis session in 11 patients from a mean 249 ± 143 pg/ml (mean \pm SD) at the start of dialysis to 77 ± 65 pg/ml at the end of the session ($p < 0.001$). During isolated UF levels did not change but fell in the ensuing sham phase indicating a time lag between volume loss and decreased generation. (136 ± 99 pg/ml to 101 ± 77.2 pg/ml; $p < 0.02$) In a subsequent study ANP concentrations were measured throughout dialysis and in the post-HD period for 2 hours. A rebound in ANP concentration was observed occurring at around 90 min post-HD. The degree of this rebound may reflect the prevailing fluid state and merit further study.

We have shown the utility of dual compartment monitoring with CSBIS-RBV technique and its potential in assessing volume changes in real time in haemodialysis patients. We have also shown the potential of ANP as an independent marker of volume status in the same setting. Both these techniques merit further study.

Contents

Abstract.....	2
Contents.....	4
Acknowledgements	10
Hypothesis	14
Abbreviations	15
Figures and Tables	17
Chapter 1.....	22
Background and Literature Review	22
1.1 Kidney Failure	23
1.2 Origins of dialysis:.....	24
1.3 Vascular Access for haemodialysis:.....	25
1.4 Frequency and adequacy of dialysis:.....	26
1.5 Cardiovascular disease in ESRD.....	28
1.6 Dry Weight:	29
1.7 Hypertension and dry weight.....	31
1.8 Mechanisms contributing to hypertension in the dialysis population.....	32
1.9 Intradialytic hypotension (IDH)	34
1.10 Physiological principles:	34
1.11 Factors determining vascular stability during dialysis:	37
1.12 Prognosis and IDH and myocardial stunning: the role of myocardial stunning.....	39
1.13 Strategies to decrease the incidence of intradialytic hypotension (IDH)	41
1.14 Residual Renal function and interdialytic weight gain	43
1.15 Techniques for use in fluid management of haemodialysis patients:	44
Chapter 2.....	50
Dialysis Machine Functions and Volume Management	50
2.1 Introduction.....	51
2.2 Relative blood volume monitoring (RBV)	51
2.21 Principles and Development	51
2.22 Clinical utility.....	52
2.23 Biofeedback Techniques - Blood Volume Tracking (BVT)	58

2.24	Limitations of RBV monitoring:	59
2.3	Control of dialysate temperature	61
2.31	Clinical Studies.....	61
2.32	Development of the Fresenius BTM [®]	65
2.33	IDH and extracorporeal energy transfer	65
2.34	Cold to isothermic to cold again?.....	68
2.35	Isothermic HD and HDF:	68
2.36	IDH and CT rise in the absence of UF:	68
2.37	Ultrafiltration profiling and sodium profiling:	69
Chapter 3	71
Bioimpedance	71
3.1	Introduction.....	72
3.2	Early History of bioimpedance	72
3.3	Basic principles	73
3.4	Body composition in bioimpedance volume modeling.....	79
3.5	Bioimpedance in the dialysis population:	82
3.6	Modification of the Col-Cole algorithm for altered hydration states:	96
3.7	A bridge from BIA to BIS.....	103
3.8	Bioimpedance methods for volume management in the dialysis population:	104
3.9	Conclusion	111
Chapter 4	114
Natriuretic peptides	114
4.1	Introduction	115
4.2	The discovery of natriuretic peptides.....	115
4.3	Structure and synthesis:	116
4.4	Actions:	118
4.4.1	Cardiovascular System:	118
4.4.2	Renal effects:	118
4.4.3	Central Nervous System:.....	119
4.4.4	Antiproliferative effects:	119
4.5	Mechanism of action	119
4.5.1	Natriuretic peptide receptors:	119
4.6	Metabolism.....	120

4.7 Role of the natriuretic peptides in cardiac diseases:.....	121
4.7.1 Cardiac failure and ischaemic heart disease:	121
4.7.2 Hypertension:.....	121
4.7.3 Diagnostic and prognostic potential:	122
4.7.4 Therapeutic potential of natriuretic peptides:.....	122
4.8 Natriuretic peptides in renal disease:.....	123
4.8.1 Significance in the dialysis population:	123
4.8.2 Therapeutic value of natriuretic peptides in Acute Renal Failure:	128
4.9 Summary.....	129
Chapter 5.....	130
Materials and Methods.....	130
5.1 Introduction	131
5.2 Techniques: General	131
5.2.1 Study Population:	131
5.2.2 Renal Plus.....	133
5.2.3 Laboratory variables:	133
5.2.4 Dialysis:	133
5.2.5 Data Acquisition set up: Finesse	134
5.3 Techniques: Specific.....	136
5.3.1 Blood Volume Monitoring:.....	136
5.3.2 Blood Temperature Monitor.....	138
5.3.3 Bio impedance Spectroscopy	140
5.3.4 Natriuretic peptides	144
5.4 Statistical analysis	145
CHAPTER 6.1	147
Dissociation between changes in blood pressure and dry weight after initiation of	147
incremental high-flux haemodialysis	147
6.1.1 Introduction.....	148
6.1.2 Subjects and Methods	150
6.1.2.1 Renal Database: (Renal Plus).....	150
6.1.3 Results:	151
6.1.3.1 Changes in Post-dialysis weight:	151
6.1.3.2 Blood Pressure trends	152

6.1.3.3 Correlation between MAP and weight reduction:	153
6.1.3.4 Incremental dialysis and residual renal function:	154
6.1.3.5 Nutritional Status	155
6.1.4 Discussion:	155
Chapter 6.2.....	160
Dual Compartment monitoring: A pilot study	160
6.2.1 Introduction.....	161
6.2.2 Materials, subjects and methods	161
6.2.3 Techniques and Materials	161
6.2.4 Study Methodology.....	163
6.2.5 Data Analysis:	164
6.2.6 Results	165
6.2.7 Analysis of RBV-RECF profiles	168
6.2.8 Discussion and Conclusions	172
Chapter 6.3.....	175
Factors influencing CSBIS.....	175
6.3.1 Introduction.....	176
6.3.2 Materials and Methods	179
6.3.2.1 Subjects:	179
6.3.2.2 Methods:	179
6.3.2.3 Procedure	180
6.3.2.4. Data analysis:	182
6.3.3. Results:	182
6.3.3.1 Patient characteristics and participation	182
6.3.3.2 Haemodynamic changes	184
6.3.3.3 Biochemical changes	184
6.3.3.4 Bioimpedance profiles during changes in electrolyte composition:.....	186
6.3.4 Discussion:	200
Chapter 6.4.....	203
Quantification of vascular refill using combined CSBA-RBV monitoring	203
6.4.1 Introduction	204

6.4.2 Subjects and Methods	204
6.4.2.1 Subjects	204
6.4.2.2 Data Collection	205
6.4.2.3 Techniques	205
6.4.2.4 Dialysis and Ultrafiltration Prescription	206
6.4.2.5 Data Analysis	207
6.4.2.6 Refill Ratio (RR).....	207
6.4.3 Results.....	210
6.4.4 Discussion	213
Chapter 6.5.....	215
Dialysate temperature and vascular refill during haemodialysis:	215
6.5.1 Introduction.....	216
6.5.2 Methods.....	217
6.5.2.1 Patients.....	217
6.5.2.2 Techniques	217
6.5.2.3 Dialysis prescription	218
6.5.2.4 Ultrafiltration prescription	218
6.5.2.5 Study Protocol:.....	219
6.5.2.6 Data analysis.....	220
6.5.3 Results.....	220
6.5.4 Discussion and conclusions	224
Chapter 6.6.....	226
Effect of High Flux dialysis on plasma	226
6.6.1 Introduction.....	227
6.6.2 Methods.....	227
6.6.2.1 Patients.....	227
6.6.2.2 Dialysis Prescription	228
6.6.2.3 Dialysis and Ultrafiltration profile	228
6.6.2.4. BNP sampling strategy	229
6.6.2.5 Measurement of BNP	229
6.6.2.6 Analysis.....	229
6.6.3 Results.....	229
6.6.4 Conclusions	232

Chapter 6.7.....	234
Evaluation of atrial natriuretic peptide as a marker of hydration state	234
6.7.1 Introduction.....	235
6.7.2 Aim.....	235
6.7.3 Methods.....	235
6.7.3.1 Patients.....	235
6.7.3.2 Dialysis and ultrafiltration profile.....	236
6.7.3.3 Study protocol	236
6.7.3.4 ANP assay:	238
6.7.3.5 Statistical Analysis	239
6.7.4 Results:.....	239
6.7.5 Discussion and conclusion	241
Chapter 6.8.....	243
Evaluation of Atrial Natriuretic Peptide as marker of fluid status in haemodialysis patients.....	243
6.8.1 Introduction.....	244
6.8.2 Subjects, materials and methods	244
6.8.3 Results.....	246
6.8.3.1 Subject 1.....	246
6.8.3.2 Subject 2:.....	249
6.8.3.3. ANP profiles in the second cohort (n =6)	252
6.8.4 Conclusion	255
Chapter 7.....	257
Discussion.....	257
Reference List.....	265

Acknowledgements

The researcher wishes to thank the following people who have helped with their time in reviewing the research protocols, suggesting improvements and helping in the setting up of equipment for these studies across the three renal units.

Dr R N Greenwood MSc, MD, FRCP

Consultant Nephrologist

Renal Unit

Lister Hospital

Stevenage

The British Renal Society

Woking

Surrey, UK

(Research Grant for the Temperature study and ANP Study)

Dr P Warwicker

Consultant Nephrologist and Clinical Director

Renal Unit

Lister Hospital

Stevenage

Dr Nathan Levin MD

Clinical Director

Renal Research Institute

New York

USA

Dr F Zhu PhD

Senior Scientist

Renal Research Institute

New York

USA

Dr S Sarkar MD

Research Fellow

Renal Research Institute

New York

USA

Dr D Wellsted PhD

RDSU and Head of CLiCIR

University of Hertfordshire

Hatfield

Ms Paula McLAREN BSc

Research Sister

Renal Unit

Lister Hospital

Dr Murugan Sivalingam MRCP

Consultant Nephrologist

Renal Unit

Lister Hospital

Dr Clare Castledine MRCP

Renal SpR

Renal Unit

Lister Hospital

Dr E Spalding MD MRCP

Consultant Nephrologist

Western Infirmary

Glasgow

Mrs Mandy Eves

Health Care Assistant

Renal Unit

Lister Hospital

Dr P Chamney PhD

Senior Engineer

Fresenius Medical Care

Germany

Dr M D Penney PhD

Consultant Clinical Biochemist

Department of Clinical Biochemistry

The Royal Gwent Hospital

Newport, UK

Dr D Hampton PhD

Senior Biochemical Scientist

Department of Clinical Biochemistry

The Royal Gwent Hospital

Newport, UK

Richard Humber

Senior Renal Technician

Renal Unit

Lister Hospital

Shahriar Rahmati

Dialysis services and Software implementation

Fresenius Medical Care

Germany

**The Renal Nursing Team across Lister, Luton & Dunstable and St Albans City
Hospitals**

Hypothesis

- Continuous Segmental Bioimpedance Spectroscopy (CSBIS) accurately reflects volume changes in the ECF compartment
- CSBIS will not be affected by changes in dialysate composition, temperature, change in subject posture or due to isovolemic HD, will remain a true indirect measure of ECF volume change.
- Dual compartment monitoring with relative blood volume (RBV) and CSBIS will provide real time information on vascular refill during dialysis
- Perturbation during dialysis by using pulse ultrafiltration (UF) followed by a rebound phase will amplify fluid shifts in the intravascular and ECF compartments that can then be analysed further to predict the 'proximity' to dry weight
- Impending hypotension can be predicted by identifying simultaneous changes in ECF and RBV traces.
- Atrial natriuretic peptide (ANP) and B-type natriuretic peptide (BNP) will be useful biochemical markers of the fluid state.
- Changes in ANP concentrations will have a volume related and dialyser clearance related components. This will be distinguishable during a dialysis session with UF.

Abbreviations

↑	increased concentrations
↓	decreased concentrations
ANP	Atrial Natriuretic Peptide
BIA	Bioimpedance analysis
BIS	Bioimpedance spectroscopy
BNP	B-type Natriuretic Peptide
BP	Blood pressure
BTM	Blood Temperature Monitor
BVA	Bioimpedance vector analysis
BVM	Blood Volume Monitor
Ca	Calcium (mmol/l)
CAD	coronary artery disease
CCF	congestive cardiac failure
cGMP	cyclic guanosine mono phosphate
CNP	C-type Natriuretic Peptide
CRF	chronic renal failure
CSBIS	Continuous segmental bioimpedance spectroscopy
CT	Core temperature as measured by BTM
CXR	chest X-ray
DBP	Diastolic Blood Pressure
DM	diabetes mellitus
DNP	Dendroaspis Natriuretic Peptide
ECF	Extracellular fluid compartment
E-control	Energy neutral dialysis during BTM
EF	ejection fraction
HD	Haemodialysis
ICF	Intracellular fluid compartment
ICF	Intracellular Fluid
Iso UF	Ultrafiltration with dialysate flow switched off
IVC	inferior vena cava
K	Potassium (mmol/l)
LV	left ventricle
LVEDP	left ventricular end diastolic pressure
LVH	left ventricular hypertrophy
LVM	left ventricular mass
LVMi	left ventricular mass index
MAP	Mean Arterial Blood Pressure
MF-BIA	Multifrequency bioimpedance analysis
Na	Sodium in mmol/L
R	Resistance (ohms)
R _{ECF}	Resistance of the Extracellular fluid compartment
R _i or R _{INF}	Resistance measured at extrapolated infinite frequency in the Cole model
R _{ICF}	Resistance of intracellular fluid
RR	Refill Ratio

R _{TBW}	Resistance of Total Body Water
SBIA	Segmental bioimpedance,
SBIS	Segmental bioimpedance spectroscopy
SBP	Systolic Blood Pressure
SF-BIA	Single Frequency Bioimpedance analysis
Sham HD	Both ultrafiltration and dialysate flow switched off, only extracorporeal circulation
SSBIS	Sum of Segmental Bioimpedance Spectroscopy
T	Dialysate temperature
TBW	Total body water
T-Control	Isothermic dialysis using BTM
UF	Ultrafiltration
WBIA	Whole body bioimpedance

Index of Tables and Figures:

Table 1.1: Factors responsible for Hypertension	32
Figure 1.1: The DeJager-Krogh Phenomenon	36
Figure: 1.2 Ultrafiltration rates according to degree of residual renal function (urea clearance [KRU]) in haemodialysis patients up to 5 years after dialysis initiation.	43
Figure 2.1 Illustration of the investigated indices. (1) "Long-term" variability (2) "Short-term" variability, (3) Slope of the linear regression line (Reproduced with permission from Beige et al Kidney International, Vol. 58 (2000), pp. 1805–1809)	54
Figure 2.2 (A) Simulation of the single exponential $[y = b e^{\frac{-x}{\tau}}]$ decays (Exp curves A, B, and C) (Reproduced with permission from Mitra et al American Journal of Kidney Diseases, Vol 40, No 3 (September), 2002: pp 556-565)	55
Table 3.1 Terminology used in bioimpedance description	73
Figure 3.1 Equivalent electrical circuit: (parallel law of summation of Resistances)	78
Figure 3.2: RXc point graph (reproduced with permission from Piccoli <i>et al</i> Kidney International, VoL 46 (1994), pp. 534—539)	80
Figure 3.3: Impedance locus:	81
Figure 3.4: Vector migration with hydration state (reproduced with permission from Piccoli <i>et al</i> Kidney International, VoL 46 (1994), pp. 534—539)	87
Figure 3.5: Relationship between normovolemia and hypervolemia with respect to dry weight (Reproduced with permission from Chamney <i>et al</i> Kidney International, Vol. 61 (2002), pp. 2250–2258)	105
Figure 3.6: Change in calf ECF (reproduced with permission from Zhu et al ; Blood Purif 2003;21:131–136)	108
Figure 3.7 : Resistance Ratio Changes in R0/Rt profile through dialysis at different dry weights (pooled data of 10 patients) Reproduced with permission from Zhu et al, personal communication	109
Figure 3.8 : RBV-R _{ECF} Profile	111
Figure 3.9: RBV-R _{ECF} profile (pulse UF)	111
Table 3.2 : Available bioimpedance technologies	113
Figure 4.1 Natriuretic peptides	116
Table 4.1: Characteristics of Natriuretic Peptides	117
Table 4.2 : Specificity of receptors for various natriuretic peptides	120
Table 4.3. Natriuretic peptides in dialysis patients	127

Figure 5.1: Finesse Data Acquisition system	136
Figure 5.2 Ultrasonic volume flow sensor:	137
Figure 5.3 Components of Fresenius 4008 Blood Volume monitor Module	137
Figure 5.4 Blood Temperature Module: Fresenius	140
Figure 5.5 : Xitron 4200 analyser, software suite and electrode placements	142
Figure 6.1.1 Weight and blood pressure changes during the first year after dialysis initiation. The Tassin experience (Charra, Bergstrom and Scribner. Am J Kidney Dis 32, 720-4, 1998)	149
Figure 6.1.2: Error bars representing post-dialysis weight during the first 12 months following dialysis initiation in 376 dialysis patients	151
Figure 6.1.3: Comparison of post dialysis weights over the first 12 months following dialysis initiation in 55 haemodialysis patients with diabetes and 322 without diabetes.	152
Figure 6.1.4 : Pre-dialysis mean arterial blood pressure trends in 362 patients at dialysis initiation and at 3, 6, and 12 months post-initiation	152
Table 6.1.1. Antihypertensive medication in 376 patients at 3, 6 and 12 months following dialysis initiation.	153
Figure 6.1.5: Scatter plot depicting change in weight and change in pre-dialysis mean arterial pressure during the first 12 months of dialysis	154
Figure 6.1.6: Fall in residual renal function during first year of dialysis in 376 incident dialysis patients at the Lister	155
Table 6.1.2: Nutritional parameters and haemoglobin in 376 haemodialysis in the first 12 months following dialysis initiation.	156
Figure 6.1.7: Comparative age distributions of Tassin and Lister incident dialysis populations	157
Table 6.1.3: Dialysis Fluid composition in Lister and Tassin	158
Figure 6.2.1: Placement of gel electrodes for calf CSBA:	163
Table 6.2.1: Patient characteristics and ultrafiltration (UF) prescription.	164
Table 6.2.2. Bioimpedance Profiles	165
Figure 6.2.2 shows the RBV, and ECF Relative Resistance (Ro/Rt) plots	167
Figure 6.2.3: RBV and ECF Relative Resistance trends in a typical patient during haemodialysis with pulse ultrafiltration	167
Figure 6.2.4: Concept of refill ratio	171
Table 6.2.3: Refill ratio for all patients in pilot study	172
Figure 6.2.5. Suggested means for improvement of Refill Ratio.	174
Table 6.3.1: Overview of Studies	178

Table 6.3.2: Patient and dialysis characteristics	183
Table 6.3.3 Reasons for withdrawal	183
Table 6.3.4. Numbers in separate sub-studies	183
Table 6.3.5: Basic clinical and haemodynamic data of patients in separate sub-studies	184
Table 6.3.6: Biochemical values (sodium, potassium, calcium) during dialysis in different sub-studies	185
Figure 6.3.1: Changes in RECF and RBV during a dialysis session with alteration in dialysate sodium	186
Table 6.3.8: Change in Resistance ratio during different phases (%)	187
Figure 6.3.2: Profile during the dialysis period using a Dialysate Na of 146	187
Figure 6.3.3: Profile during the dialysis period using a Na of 130	187
Figure 6.3.4: Profile generated during dialysis period with dialysate Na 138	188
Table 6.3.9: Composite Resistance Ratio change of all 7 patients plotted at 1 minute intervals for each intervention	188
Figure 6.3.5: Composite Resistance ratios of all 7 patients during terminal 10 minute phase of each sodium concentration	189
Figure 6.3.6: Changes in Resistance Ratio in the first 90 minutes of dialysis.	190
Table 6.3.10. Results of ANOVA comparison of slopes over 5 minute periods during dialysis at different dialysate sodium concentrations.	191
Figure 6.3.8: Comparison of slopes over 5 minute periods during dialysis at different dialysate sodium concentrations	191
Figure 6.3.9: Comparison of slopes for dialysate Ca and K interventions	192
Figure 6.3.10: Comparison of slopes for different postures and temperatures	195
Table 6.3.11: Changes in monitored variables during one hour of isovolaemic dialysis –	193
Table 6.3.12. Ultrafiltration volumes (UF), and mean ultrafiltration rates (ml/kg/hr) in 3 patients studied by dual compartment monitoring over 10 successive dialysis sessions.	194
Figure 6.3.11: Resistance ratio during first 60 minutes of dialysis with UF in 3 patients over 10 successive sessions	196
Table 6.3.12. Results of curve fitting in 25 sessions in 3 patients in which decay of Resistance ratio fitted first order kinetics.	197
Figure 6.3.11 : Characteristics of first order decay	198
Table 6.3.13 R_{ECF} values in 12 subjects:	198
Table 6.3.14 Lack of association between R_{ECF} at the start of dialysis and the corresponding UF	198
Figure 6.3.12 Variation in the start R_{ECF} of Subject BD	199

Figure 6.4.1: Cartoon representing modified HD session T_d : Dialysis duration, t : duration of specified segment	207
Fig 6.4.2: A complete CSBA-RBV profile: R1 is the first rebound phase (HDiso), R2 second rebound phase, Y-axis represents R_0/R_t which is the ratio of R_{ECF} at time 0 (start of dialysis) to time t , X-axis represents absolute time	208
Fig 6.4.3: Concept of Refill Ratio (RR) ($A1/B1$). $A1$ is the difference between R_0/R_t and RBV values at the start of R1, the R_0/R_t value having been adjusted to 100 % at start of R1. $B1$ represents a similar value at the end of R1.	209
Fig 6.4.4: Refill ratio ($A2/B2$) during second rebound period (RR2)	210
Table 6.4.1 Characteristics of the 29 studied patients	210
Figure 6.4.5: Comparison of Refill Ratio for Rebound phase 1 (RR1) and rebound phase 2 (RR2) phases in 29 patients at baseline ($p = 0.001$)	211
Table 6.4.2: RR profile of 21 patients who achieved weight reduction prior to repeat monitoring	212
Figure 6.5.1 Ultrafiltration prescription	219
Figure 6.5.2 Composite curves showing core temperature trends	222
Table 6.5.1. Basic haemodynamic details of the two phases.	221
Table 6.5.2: Change in Relative blood volume (RBV) and energy loss	222
Figure 6.5.3 Regions of interest for the calculation of refill ratios	222
Tables 6.5.3a. UF-1 and UF2 volumes and Refill Ratios for Phase N	223
Tables 6.5.3b shows the UF-1 and UF2 volumes and Refill Ratios (RR1 and RR2) for Phase T	224
Table 6.6.1 Patient characteristics	228
Figure 6.6.1. Schema depicting the structure of the dialysis and ultrafiltration perturbations throughout the session. The schema also depicts the BNP sampling strategy.	229
Table 6.6.2 BNP levels during the study	230
Figure 6.6.1. Plot of log-transformed BNP levels throughout the phase of the study	231
Table 6.7.1; Clinical and dialysis characteristics of 11 study patients	236
Figure 6.7.1: Schema of sub-phases of study and sampling intervals	238
Figure 6.7.2 ANP levels at the start and end of the dialysis session	240
Figure 6.7.3: Error Bars representing serial ANP concentrations through different phases of dialysis	241
Fig 6.8.1: Subject 1. ANP and BNP concentrations during dialysis along with RBV and UF traces	247
Fig 6.8.2: ANP and BNP concentrations in the interdialytic period (Subject 1)	248

Fig 6.8.4: ANP and BNP concentrations in subject 2 during the inter-dialytic period	251
Table 6.8.1: Subject demographics.	253
Table 6.8. 2: ANP concentrations in all six patients. (De: end of dialysis session, De + 1: one hour post-dialysis, De + 2: 2 hours post dialysis)	253
Fig 6.8.5: Delayed rebound of ANP concentrations in the post-dialytic period	255

Chapter 1

Background and Literature Review

1.1 Kidney Failure

The kidneys maintain a near constant composition of the internal environment including the volume, tonicity and compartmental distribution of the body fluids. This is achieved by a careful regulation of ultrafiltration at the glomerular level and reabsorption of the ultrafiltrate at the tubular level. Around 180L/day of plasma water is ultrafiltered through the glomeruli equivalent to a glomerular filtration rate (GFR) of 125ml/min. Ninety nine percent of this ultrafiltrate is reabsorbed by the tubules resulting in an average urine output of 1.5L/day. The renal blood flow accounts for 20 percent of the cardiac output though the kidneys comprise only 1 percent of the total body weight.

Renal failure results in a grossly deranged metabolic state characterised by accumulation of various toxins leading to acidosis, electrolyte and fluid state disturbances, anaemia and poor nutrition. These effects begin to appear as the GFR falls below around 30ml/min and are pronounced when GFR reaches 10ml/min. Irreversible renal disease characterised by falling GFR below 15ml/min is classified as End Stage Renal Failure (ESRF) or Stage V Chronic Kidney Disease (CKD). Management of stage V CKD in developed countries is usually with renal replacement therapy (RRT).

UK Renal Registry data (2008 report)[1] shows that over 6500 patients commenced RRT in the UK in 2007, an annual incidence of 108 pmp. The UK prevalent RRT population, at over 45,000 (745 pmp), is continuing to increase at around 5.0% per annum. The most common treatment modality in the prevalent population was transplantation (46.6%), closely followed by centre-based HD (42.1%).

The current practice of nephrology involves a considerable proportion of the clinician's time being spent on the management of patients on RRT. As a cohort these patients have a one year survival of 78% (unadjusted for age). This improves to 87% when the initial 90 days of RRT is taken out of consideration. The 5 year survival rate is around 45%. The high mortality and morbidity in these patients is mediated by numerous factors notably primary renal disease, and the increasing age, comorbidity (particularly cardiovascular comorbidity), and dependency of the dialysis population.

Haemodialysis, in particular, results in substantial changes in the fluid status over the duration of dialysis session, which are often poorly tolerated. Short duration intermittent therapy poses a substantial stress on the cardiovascular system, frequently resulting in intradialytic hypotensive episodes which may co-exist with hypervolemia, and the resultant hypertension, in the inter-dialytic period. Regular, accurate assessment of fluid status is needed to maintain near euvolemia in these patients and the current time-constrained clinical practice does not always allow this. Furthermore the techniques available to assist in fluid state management are not always accurate, are often time consuming and not easily applicable to routine clinical practice

1.2 Origins of dialysis:

The term dialysis was coined by Thomas Graham, Professor of Chemistry at the Anderson's University in Glasgow in 1861. The term was used to describe the process of diffusion of crystalloids through plant parchment coated with albumin[2]. Using this method, he could extract urea from urine. Dialysis in experimental animals was first conducted by Abel, Rowntree and Turner in 1913. They created the first artificial kidney using a cellulose derivative called collodion. Collodion was configured into tubes contained in a glass jacket. Anticoagulation was achieved using hirudin. Using this 'vividiffusion' device the authors observed separation of serum from blood as it passed through the collodion tubes filling the space outside in the glass jacket. The inventors envisaged the use of such a device to treat humans suffering from toxic states such as kidney failure.[3] Georg Haas conducted the first dialysis session in an uremic patient in 1924 at the University of Giessen in Frankfurt. The session lasted for 15 minutes and further six similar treatments were conducted, the last of which used heparin as an anticoagulant [4]. The first practical dialysis device was invented by Kolff and Berk in Netherlands in 1943[5], and used successfully to treat a patient with acute renal failure This rotating drum artificial kidney consisted of 30-40 metres of cellophane tubing in a stationary 100-litre tank. Modifications of the Kolff dialyser during the ensuing 20 years led to establishment of haemodialysis as a viable treatment for kidney failure in the acute setting. [6-8]

Cellulose membranes became widely available during this time and development continued with subsequent modifications to membrane morphology by use of substituted derivatives of cellulose. The pathway towards the use of haemodialysis in long-term treatment of patients with chronic kidney disease, was also paved by the availability of purified heparin, standardisation of dialysis fluid preparation, including use of acetate as buffer, and most importantly by the development of techniques for the establishment of sustainable vascular access.

1.3 Vascular Access for haemodialysis:

Scribner, Dillard and Quinton invented the first long term vascular access device using a polytetrafluoroethylene (PTFE) tubing as a shunt between the radial artery and cephalic vein. Blood flow rates of 100ml/min were achieved and most importantly the shunt could be used repeatedly.[9-11] This led to the development of the first hospital based chronic treatment programme in Seattle in 1960.[12;13] By this time membrane technology had moved away from drum type dialysers to that of parallel plate low resistance cellulose dialysers introduced by Kiil[14]. The problem of batch processing of the dialysate fluid had been solved by the method of proportional pumping and the introduction of acetate as a buffer circumvented the precipitation problems encountered with bicarbonate.

In 1966 Brescia and Cimino developed the subcutaneous arteriovenous fistula by anastomosing the cephalic vein to the radial artery.[15;16] This provided a further impetus to long-term haemodialysis by minimising the embolic and clotting problems encountered with the Scribner shunt. Parallel plate dialysers were replaced by hollow fibre dialysers in the 1970s.[17] Membrane technology was further improved with the introduction of synthetic membranes. These membranes could be fashioned with permeability characteristics substantially greater than those of cellulose-based membranes. High-flux membranes allowed greater convective clearances and increased the potential for removal of middle molecules.[18] Improvements in dialysis delivery systems over the ensuing decades have allowed huge expansion of dialysis programmes. More than a million patients worldwide were receiving dialysis by 1999, with the number expected to hit 5 million by the year 2020.

1.4 Frequency and adequacy of dialysis:

Long-term dialysis was initially performed every 5-7 days for 18-24 hours. This did not ameliorate patient symptoms of fluid overload, hypertension, bone disease and neuropathy. These features were better controlled by the 10-16 hour twice weekly sessions which followed. Rationing of hospital based treatments resulted in the start of a home haemodialysis programme in Seattle with patients dialysing on parallel plate dialysers for 8-10 hours overnight three times a week.[19] Symptom control in patients dialysed using these regimens was substantially better and the era of thrice weekly haemodialysis therapy was born.[12;20-23] Eight hour sessions three times a week became the norm.

However, patient's symptoms did not correlate with pre- or post-dialysis urea or creatinine and the need was perceived for measures which quantified dialysis delivery. This was especially important since the advent of hollow fibre synthetic dialysers, improved dialysis delivery systems, and robust vascular access, had fuelled a culture of shortening treatment times.[24] The National Cooperative Dialysis Study (NCDS) was designed to compare the effects of high and low small solute clearance and short and longer treatment times on outcome in long-term dialysis patients. The study concluded that the duration of dialysis did not have a significant effect on medium term outcome as long as small solute clearance was high.[25-29] Subsequent reductions in treatment times in the US contributed to a significantly increased mortality in the US dialysis population.[30-34] Re-analysis of the NCDS data later led to the mechanistic modelling of urea clearance and to the introduction of the concept of normalised urea clearance (Kt/V), which is now widely used as a measure of dialysis adequacy.[35]. The parameter K refers to the urea clearance by dialysis, t to the dialysis duration, and V to the patients's urea distribution volume which is equivalent to the total body water. Delivered Kt/V can be estimated from pre- and post-dialysis blood urea levels. The reanalysis suggested that a single pool $Kt/V > 0.9$ for a thrice weekly session was associated with improved outcome provided nutrition was adequately maintained.

Subsequently, observational data suggested that improvements in outcome continued beyond a single pool Kt/V of 1.2.[36-42] This translates to a dialysis duration of 4 hours three times a week. It also became apparent that there was a need to take into account two-pool effects on dialyser urea clearance

especially for shorter treatment times. Such two-pool effects are the consequence of intercompartmental disequilibrium and result in a significant post-dialysis rebound of blood urea levels, which is larger following more rapid dialysis sessions.[43-49] These considerations led to the concept of the two-pool Kt/V and to the equilibrated Kt/V , which effectively makes use of an estimated post-rebound blood urea value in the Kt/V calculation.[50-53] There were also suggestions from observational data that there may be a survival advantage of treatments using high-flux rather than low-flux membranes. [54-61]

The HEMO study [62] was designed to compare outcomes (mortality) for what was by then regarded as standard doses for thrice-weekly treatment (an equilibrated Kt/V of 1.05 approximately equivalent to a single pool Kt/V of 1.25) to outcomes using higher doses (equilibrated Kt/V of 1.45 approximately equivalent to a single pool Kt/V of 1.65). Outcomes using high-flux and low-flux membranes were also compared. The study found that primary outcome, death from any cause, was not significantly influenced by either the dose or the flux assignment. [63;64] Subsequent dosing guidelines have been based on the findings of this study with the acceptance that these doses define the limits of thrice weekly treatments. However, since the HEMO study, there has been much interest in exploring the potential benefits of more frequent treatments on outcome, and a number of randomised studies are underway.[65-67]

Solute clearance, however, is only one aspect of the treatment goal. Another major aspect is optimisation of the fluid state. Intermittent haemodialysis leads to cyclic alterations in the volume status with associated changes in blood pressure. Interdialytic hypertension is often the result.[68] Shorter duration therapies predispose patients to intra-dialytic symptoms when fluid state optimisation is striven for within the constraints of the truncated sessions. There is now an increasing recognition of the pitfalls of a Urea Kinetic Modelling based approach as the sole determinant of dialysis adequacy. With this there has been a shift in emphasis to an inclusive approach that treats solute and volume removal as distinct elements of the dialysis equation. This requires a radical re-think of the duration of dialysis sessions with a need to develop home based therapies[69-75], alternate day dialysis sessions eliminating the two day weekend, daily dialysis in certain situations and adoption of new technologies not dissimilar to the modular model of APD[76].

1.5 Cardiovascular disease in ESRD

Symptomatic ESRD is usually characterised by hypervolemia, hypertension and increased sympathetic activity causing vasoconstriction.[77] Progressive salt retention, as renal function declines, is the driver for ECF volume expansion. Antihypertensive agents are usually prescribed along with diuretics as renal function declines. The degree of hypertension varies with the aetiology of renal dysfunction. The accumulation of vasoconstrictor agents like asymmetrical dimethylarginine (ADMA), ouabain-like peptides and decreased nitric oxide (NO) activity further amplifies the tendency for hypertension.[78;79]

When patients are established on dialysis, the expanded ECF compartment is gradually reduced to its normovolemic state by sequential ultrafiltration. The attainment of euvoemia is a clinical judgement and a large proportion of patients remain volume overloaded in spite of best clinical efforts.[80] This volume element, associated with altered vascular reactivity and the imbalance between vasoconstrictor and vasodilatory mediators, promotes left ventricular dysfunction and myocardial fibrosis.[81-83] Anaemia, which is very common in advanced renal disease, also contributes to concentric or eccentric ventricular hypertrophy.[84-86] Intradialytic hypotension, symptomatic or otherwise, is now recognised to cause myocardial stunning that further compromises cardiac function.

Pre- and post-dialysis blood pressures have independent associations with mortality, though the associations are complex.[87-89] Observational data frequently demonstrate features of “reverse epidemiology”[90], patients with blood pressures in the lower ranges having the highest mortality risk – presumably because of co-existent heart failure. Wide pulse pressures reflecting older age and co-existent cardiovascular co-morbidity, also increase risk. Larger interdialytic weight gains (IDWG) are associated with shorter survival when co-morbidity is taken into account. With increasing acceptance rates and consequent inclusion of a larger cohort of elderly patients,

management of the cardiovascular disease burden takes up a substantial proportion of the physician's time. [91-95]

Rigorous management of the volume state can potentially minimise cardiovascular disease burden by improving blood pressure control in the inter-dialytic period. This is amply demonstrated by Charra et al in their cohort of patients dialysing over a longer time than that is conventionally practised, allowing for optimal fluid removal at low ultrafiltration rates. The resultant improvement in blood pressure control translates to better survival, though these effects may also be contributed to by other factors including significantly better dialysis adequacy.[68;96-99] The cohort of patients in whom the blood pressure normalised showed lower systemic vascular resistance. The explanation for this remains unclear but it may involve changes in non-osmotically active sodium bound to glycosaminoglycans in the vessel wall.[100] Mass sodium removal within the constraints of intermittent short duration dialysis, however, remains incomplete in many instances, contributing to inter-dialytic hypertension and progressive cardiac dysfunction.

1.6 Dry Weight:

Dry weight is defined as the lowest weight a patient can tolerate without intradialytic symptoms and/or hypotension and in the absence of overt fluid overload.[101] There is as yet no adequacy measure for optimal fluid removal during dialysis. Dry weight is usually clinically 'judged' based on observations of pre-dialysis blood pressures, interdialytic blood pressure profiles if available, examination of the neck veins, auscultation of the chest for signs of volume overload and presence or absence of peripheral odema. Physiological dry weight is the weight resulting from normal renal function, preserved vascular permeability, normal serum protein concentration and normal body volume regulation.[102] A number of factors may influence the designation of dry weight in the haemodialysis patient. These include nutritional state, residual renal function, the integrity of cardiovascular reflexes, and the presence or absence of concomitant antihypertensive therapy.

The majority of patients initiating dialysis therapy are in a catabolic state and improvement of the internal milieu as a result of treatment, can result in improved appetite, a gain of lean body weight and the need to reassess dry weight and revise it upwards. An accurate assessment of dry weight, from the clinical perspective depends on the knowledge of body compartments and an idea of the degree of volume expansion in each of these compartments. Furthermore solute concentration and interdialytic weight gain need to be accurately known to prescribe the ultrafiltration rates for individual dialysis sessions. An imprecise dry weight estimation often leads to deleterious consequences which may impact on long term survival and quality of life in dialysis patients.

Eighty percent of all hypertension in the dialysis population is related to chronic hypervolemia.[103] Salt and water excess secondary to decreased excretion consequent to nephron loss can be ameliorated by dialysis. Charra et al have achieved normotension in their patients through a combination of dietary sodium restriction and long hours dialysis. They have also observed a lag period between the decrease in weight and normalisation of the blood pressure[104]. Although the renin-angiotensin-aldosterone system, and other factors such as increased sympathetic drive and endothelial dysfunction have been implicated in the genesis of hypertension, the overwhelming evidence points towards the critical role of volume overload.[105-107] The consequence of an over-estimation of the dry weight is therefore hypertension. Hypertension is likely to be a major factor in the hugely increased cardiovascular and cerebrovascular morbidity and mortality in the dialysis population.[108] Left ventricular dysfunction, left ventricular hypertrophy and accelerated atherosclerosis are common outcomes of fluid overload and accompanying hypertension.[109-112] The age of incident patients on dialysis programmes is now significantly higher than it was two decades ago. There has been a concomitant increase in the prevalence of various co-morbidities such as diabetes, ischaemic heart disease in incident patients. All of these impact on mortality. The consequences of fluid overload and hypertension are amplified in these circumstances. Thus it is of paramount importance that the volume state is rigorously monitored and controlled in dialysis patients.

1.7 Hypertension and dry weight

Hypertension in the dialysis population is widely prevalent, the UK Renal Registry report of 2008 reports 18/48 units returning BP data showing >50% of patients having BP higher than 140/90mmHg pre-dialysis. Forty eight percent of haemodialysis patients achieve target BP pre-HD.[113] The data from HEMO reported >70% of patients to be hypertensive[114] whilst a recent USRDS survey showed 91% of the renal physicians prescribing antihypertensive agents with 75% of patients remaining hypertensive[115].

Hypertension in a large majority of dialysis patients is volume related. Overt clinical evidence of an expanded volume is not often obvious in prevalent patients. This relates both to the limitations of clinical assessment as well as to the logistic difficulties involved in instituting regular routine assessments in busy units. There is evidence from numerous studies that if the volume state were assessed frequently, if dialysis sessions were prolonged and if an established patient education programme existed to help optimise salt and water intake, most patients will achieve normotension. This is amply borne out in the cohort of patients who had dialysed in Tassin with long sessions (often 8 hours thrice weekly), with relatively low dialysate flow rates and use of acetate as the buffer[116]. Similar data has also been reported by Goldsmith *et al* [117;118] in their cohort of 35 long session home haemodialysis patients whose ambulatory blood pressures averaged 115/66 mm Hg and without resort to hypotensive drug therapy. The echocardiographic characteristics of these patients were significantly different to those of a corresponding cohort of in-centre HD patients showing lesser eccentric LVH and well preserved systolic function. The improved survival demonstrated by Charra *et al* in their cohort is linked to the prolonged sessions allowing for better ECF volume normalisation and their rigorous pursuit of the correct dry weight.

The relationship between a correct dry weight when the ECF volume is normal and BP control is non-linear. There is a time lag between reductions in weight and achievement of normotension. This can be up to 6 months as demonstrated by Charra *et al* in their cohort. This lag phenomenon is thought to be

primarily related to the altered vascular reactivity causing increased peripheral arterial resistance in response to the ECF expansion occurring as progressive nephronal loss leads to ESRD.[119;120]

Blood pressure is regulated by cardiac, renal and neurohormonal factors as alluded to by Guyton and colleagues[121]. The loss of this autoregulation when kidneys fail leads to hypertension in a majority of dialysis patients.

When ECF volume expansion occurs, the cardiac output increases in response. This is followed by an increase in peripheral vascular resistance protecting against end organ injury. The rise in blood pressure that follows the increase in vascular resistance results in natriuresis restoring volume and thereby normalising blood pressure. In ESRD the natriuretic mechanisms are absent and progressive nephronal loss leads to increasing vascular resistance and hypertension as the ECF compartment expands.

1.8 Mechanisms contributing to hypertension in the dialysis population

Table 2.1: Factors responsible for Hypertension

ECF Expansion	<ul style="list-style-type: none"> • Non compliance with salt and water restriction • Vasoactive substances in circulation • Non-osmotically active sodium
Dialysis Prescription	<ul style="list-style-type: none"> • Short sessions • Dialysate sodium and potassium • Erroneous dry weight estimations
Vascular reactivity	<ul style="list-style-type: none"> • Abnormal Calcium-phosphate product • Hyperparathyroidism • Vascular calcification and stiffening • Coexisting peripheral vascular disease
Drug and Toxin related	<ul style="list-style-type: none"> • Erythropoietin • Smoking • Over the counter medicines- nasal decongestants/sympathomimetics

Circulating factors

- Inhibition of Nitric Oxide systems
- Na⁺-K⁺ ATPase inhibition
- “uremic toxins”
- Parathormone

Renal mechanisms

- Aetiology of renal failure
- Dysregulated Renin-angiotensin axis
- Renal ischaemia/Renovascular disease
- Sympathetic hyperactivity

Table 1 highlights the major factors which have been implicated in the pathogenesis of hypertension in the ESRD population. Many of these factors can be modified by encouraging salt restriction, adequate dialysis and an accurately determined dry weight. However, the effect of various circulating agents on the systemic vascular resistance also needs to be considered. These include inhibitors of the nitric oxide system such as asymmetrical dimethyl arginine (ADMA)[122-125], ouabain like compound (OLC), digoxin like immunoreactive substance (DLIS)[126] and neuropeptide-Y[127]. OLC and DLIS have a large volume of distribution and therefore are poorly cleared during dialysis. Maintenance of the euvolemic state over a period of time will result in lowering of concentrations of these agents thereby normalising blood pressure. This is now accepted to be a coherent explanation for the lag phenomenon described by Charra and his colleagues. Slow mobilisation of non-osmotically active sodium, which is “stored”, particularly in the skin, may also have a role[128]

Achieving optimal salt and water balance in short session dialysis is difficult and blood pressure remains a vexing issue with most physicians resorting to pharmacological therapy. The repeated re-reinforcement of a <5g salt diet and its importance in maintaining normotension has again been described by Shaldon and Vienken in their cohort in 2006[129]. Ozkhaya *et al* had adopted a similar approach to salt restriction along with the provision of slightly prolonged dialysis sessions and extra sessions in select patients to

achieve normotension over a period of time in a majority of their patients without resort to pharmacological therapy. The physician assessments were more frequent and this helped in the reinforcement of the dietary message.[130-132] Agarwal *et al* had also reported reductions in blood pressures when dry weights were reduced in the study cohort of 100 patients by 0.9kg in 4 weeks and 1 kg in 8 weeks. The interdialytic ambulatory BP reduced by an average of 7mmHg systolic and 3mmHg diastolic when compared to the control population.[133]

1.9 Intradialytic hypotension (IDH)

Dialysis related hypotension occurs in at least 20% of sessions and contributes significantly to morbidity.[134-136] Intra-dialytic hypotension in a significant proportion of patients is also associated with post-dialysis hypotension. A lower blood pressure has been shown to be associated with increased morbidity and mortality in the dialysis population secondary to impaired cardiac function.[137] With the increased acceptance of elderly patients onto dialysis programmes and patients with higher comorbidities, management of dialysis related hypotension has become more challenging. In addition, the current dialysis practice forces the adoption of higher UF rates within shortened sessions increasing the propensity for hypotension. Poor reinforcement of the restricted salt diet in many dialysis centres contributes to larger inter dialytic weight gains (IDWG) causing intra-dialytic hypotension, interdialytic hypertension and inappropriate anti-hypertensive drug use.

The hypotensive episodes may also cause poor cardiac perfusion, mesenteric ischaemia and access malfunction.[138;139]. Progress has been made in the management of these episodes over the last 20 years, though, there still remain a significant proportion of patients in whom interventions fail.

1.10 Physiological principles:

Decreased circulating blood volume causes hypotension during dialysis. Various compensatory mechanisms exist to preserve cardiac filling during fluid removal. Some of the important factors are mentioned below.

- Decreased venous capacity
- Augmented cardiac contractility and rate
- Redistribution of cardiac output by selective increased vascular resistance through activation of cardiopulmonary and baroreceptors

1.10.1 Decreased venous capacity

In normal conditions, the venous capacitance vessels can sequester a significant proportion of the total blood volume, that can change markedly in conditions of hypovolemia. The capacitance of the venous bed can be altered by neuro-endocrine mechanisms and by decreased regional filling. Neuronal venoconstriction in capacitance beds is poorly understood in humans and may not be a significant factor in countering decreased circulatory volume.

The regional filling can be decreased by the so called DeJager-Krogh phenomenon[140]. When the resistance is increased in the vessel supplying a compliant vascular bed, flow is reduced as well as the downstream distending pressure. Loss of pressure leads to a passive recoil of the capacitance bed pushing blood into the draining vein thereby augmenting cardiac venous return. (Figure 1.1)

This decrease in regional filling is readily evident in the splanchnic and cutaneous vascular beds in the setting of hypovolemia. In addition, the splanchnic vasculature is richly innervated by alpha and beta adrenergic fibres, the increase in norepinephrine in conditions of hypovolemia cause venoconstriction, decreasing the volume in the splanchnic bed and increasing cardiac preload.

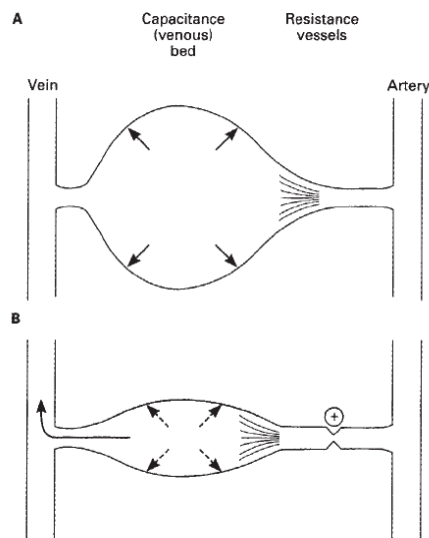

In the top panel (A) the resistant vessel tone is low and the flow through the compliant vascular bed is high, this increases distension pressure causing sequestration of blood in venous bed.

In the lower panel (B), the resistance vessel tone has increased causing a fall in tone as well as the distending pressure in the capacitance bed. Fall in pressure causes a passive recoil of the capacitance bed decreasing its capacity and translocating the previously sequestered blood into the draining vein

Figure 1.1: The DeJager-Krogh Phenomenon

1.10.2 Changes in cardiac contractility and rate:

The heart rate increases initially in response to hypovolemia. This is transient and is usually followed by an increase in cardiac contractility aiming to preserve the stroke volume. Stroke volume is largely pre-load driven, therefore, changes in contractility alone is not significant in preserving haemodynamic stability.

1.10.3 Redistribution of cardiac output:

Cardiopulmonary receptors in the atria and pulmonary vessels exert a constant degree of tonic inhibition of sympathetic outflow to the resistance vessels in skeletal muscle and splanchnic circulation.[141] In early stages of hypovolemia, even before changes in pulse or mean arterial pressure are manifest, the ‘switching off’ of the tonic inhibition by activation of the cardiopulmonary receptors causes an increased tone in resistance vessels to skeletal muscle, splanchnic circulation and the skin. This would increase venous return as described through the DeJager-Krogh phenomenon. As hypovolemia becomes more significant the baroreceptors in the arch of aorta and the carotids sense the drop in mean arterial pressure (MAP) and also abolish the tonic inhibition of sympathetic outflow causing further increases in vascular resistance to the aforementioned organ systems and effecting similar changes in the renal microcirculation

as well. Associated with these changes are the increases in concentrations of various vasoactive agents like norepinephrine, renin, aldosterone and later stages vasopressin and adrenaline. This sequence of events attempt to compensate for fluid loss and preserve vital organ perfusion. The venoarterial reflex and the leg muscle reflex also come into play effecting emptying of capacitance vessels in this situation.

1.11 Factors determining vascular stability during dialysis:

1.11.1 Cardiac function:

Progressive renal dysfunction leading to ESRD is usually associated with salt and water retention causing most patients to be hypertensive at the time of starting dialysis. Cardiac dysfunction is a norm rather than an exception. In the presence of diastolic dysfunction, higher filling pressures are required to maintain a cardiac output. This is of course difficult to sustain when fluid is being removed from the intravascular space. Hypotension often ensues. This can be mitigated by either adopting a slower UF rate and therefore a longer session or daily sessions of short duration during day or longer sessions nocturnally. Hypotension rarely complicates nocturnal daily HD. [142-144]

Overt systolic LV dysfunction is also very common and this improves significantly with decreases in preload as progressive weight reductions are achieved by sequential UF.[145] Antihypertensive drug therapy may modify the sympathetic drive and also hamper compensatory rate control responses to fluid removal.

Lastly significant coronary artery disease in the context of ESRD increases the risk of haemodynamic compromise significantly and any ensuing hypotension will further worsen myocardial function by diminishing perfusion.[146;147]

1.11.2 Plasma refill

Isovolemic dialysis is not usually associated with significant changes in plasma volume. It is feasible that volume shifts happen between plasma volume and ECF determined by the dialysate sodium gradient. Nette *et al* [148] reported a rise in RBV during the first and second hour of a 4 hour isovolemic dialysis session in six stable HD patients. The increases in RBV were 2.4 and 2.5% respectively and the authors concluded that this may be related to changes in vascular resistance or the result of inter-compartmental

fluid shifts. Hypovolemia causing reduced cardiac filling is the driver for hypotension and is offset by the compensatory mechanism of vascular refill from the ECF. In a typical dialysis session, the ultrafiltrate volume ranges between 1.5-2 L that is 50-60% of the plasma volume. It is a tribute to the cardiovascular compensatory mechanisms that hypotension does not occur more frequently. Plasma refill is very brisk in the presence of significant interstitial oedema and slows considerably as target weight is approached. Any intervention that maximises and quickens vascular refill will confer better vascular stability for a given UF rate. Such interventions may be altering dialysate sodium concentrations[149-151], withdrawal of vasodilatory antihypertensive agents, ensuring adequate nutritional status with maintenance of normal serum albumin and reinforcing the message on salt restriction. In addition to salt intake, high plasma renin activity also drives thirst and use of angiotensin converting enzyme inhibitors (ACE-I) to modify this may reduce IDWG.[152]

Diminished plasma refill is often seen in elderly, patients with significant cardiac disease, in the presence of hypoalbuminemia and with the use of beta blockers, vasodilators and alpha blockers. Enhanced oxidative stress[153], production of pro-inflammatory cytokines[154], abnormalities in the nitric oxide (NO) pathway[155], decreased endothelin-1 and rise in highly sensitive CRP [156] signifying inflammation occur in a significant proportion of long term dialysis patients. This inflammatory state alters vascular permeability and predisposes to hypotension. Use of acetate as a buffer causes venodilatation in the splanchnic beds reducing efficiency of refill.[157] Food ingestion during dialysis produces a similar effect.[158] Dialysate temperature higher than the core temperature causes 'thermal stress' towards the latter half of dialysis when the energy dissipation fails in the face of reduced cutaneous circulation heralding rapid vasodilatation and hypotension.

1.11.3 Capacitance venous beds and the interaction with arterial tone:

Maintenance of an appropriate arterial and venous tone is essential to sustain pre load.[159] Loss of sympathetic tone in the capacitance beds causes peripheral pooling and hypotension. Cardiopulmonary and baro receptors release their inhibition of the sympathetic tone as atrial filling pressure falls and the augmented sympathetic activity 'squeezes' the compliant capacitance venous beds in the skeletal muscle,

splanchnic circulation and lesser extent the skin to maintain preload as fluid is being removed through UF.[160] This sympathetic tone may collapse if the tissue perfusion cannot be sustained. Poor perfusion is accompanied by increased adenosine tri-phosphate (ATP) breakdown into adenosine di-phosphate (ADP) and adenosine mono-phosphate (AMP). AMP is metabolised to adenosine and eventually to inosine, hypoxanthine and uric acid. Adenosine release causes hypotension by inhibition of norepinephrine. This can cause a sudden change in sympathetic tone precipitating hypotension. However, support for this hypothesis remain sketchy.[161]

1.11.4 Sympathetic nervous system (SNS) dysfunction:

Another factor thought to be responsible for intradialytic hypotension in this population is the paradoxical decrease in SNS activity in a cohort of hypotension prone patients. ESRD is a state characterised by heightened SNS activity and this can be demonstrated, for instance, by the frequency of impulse propagation in the peroneal nerve through implanted microelectrodes. The rapid neuronal firing is a characteristic of ESRD and is not seen in anephric patients. When patients start dialysis, the SNS activity can be shown to increase significantly as a response to fluid removal.[162;163] In some patients, the activity paradoxically slows down and is now thought to be centrally mediated by the so called Bezold-Jarisch reflex. Afferent fibres in the inferior wall of the myocardium, when triggered, cause hypotension and bradycardia. This can be seen in patients with inferior wall myocardial infarction (MI), during coronary angiography and in vasovagal syncope. A heightened sensitivity in some dialysis patients can precipitate hypotension if relative ischaemia of the inferior wall occurs in response to hypovolemia [164]. Autonomic dysfunction *per se* in the setting of uremia, in association with diabetes or in the very elderly can cause a failure in the maintenance of the vascular tone during fluid removal precipitating hypotension.

1.12 Prognosis in relation to IDH: the role of myocardial stunning

The propensity for HD to cause cardiovascular instability is also clear from this discussion. Repeated IDH episodes are now well recognised as an independent predictor of mortality. Even in the absence of significant coronary artery disease (CAD), dialysis patients run the risk of cardiac failure, dysrhythmias

and sudden death. Recent evidence points to the risk of 'myocardial stunning' during dialysis with UF that can potentially lead to progressive cardiac dysfunction. The decreased coronary flow reserve (CFR) seen in many dialysis patients consequent to increased peripheral arterial resistance, low grade LV fibrosis and eccentric hypertrophy predispose to 'stunning' when stressed by ultrafiltration. It has been long known that dialysis induces cardiac ischaemia, Zuber *et al*[165] reported on ST-T wave changes during dialysis and HF in 1989.

Further studies have alluded to the occurrence of ST-segment depression to be between 15-40%[166-168]. Rises in cardiac troponins (cTnT and cTnI) during and after dialysis have been observed by many investigators and this has been correlated strongly to mortality in many instances[169-176]. The timing of these measurements have led to some ambiguity of their importance as prognostic markers as these markers are best measured 4-6 hours post-HD or in the inter-dialytic period.

Singh *et al* [177] reported on the incidence of dialysis induced ischaemia in 10 asymptomatic patients assessed by sestamibi single photon emission computed tomography (PET) observing perfusion defects in 7/10 patients with only 3 of these patients showing ECG changes of ischaemia. McIntyre's group[178-181] in the UK have studied the phenomenon of 'myocardial stunning' in many of their HD cohorts reporting on beneficial effects of cool dialysate in improving LV dysfunction and also the usefulness of RBV based biofeedback in reducing the progression of LV dysfunction when compared with standard HD. In seventy of their patients, 64% developed myocardial stunning as evidenced by the development of regional wall motion abnormalities (RWMA) during dialysis. This associated with a rise in cTnT were the two most important factors increasing the hazard of death in this cohort of patients. Subsequent analysis of myocardial blood flow (MBF) in 4 patients (3 diabetic), by PET scans, showed a global reduction in MBF during dialysis and reductions in segmental MBF in areas that developed RWMA. Partial recovery was observed in all patients 30 minutes post-HD in terms of their RWMA but only 23% in terms of function of the affected segment. These patients had normal coronary artery anatomies on catheterisation prior to their entry into the study.

Casper Franssen's group in Netherlands studied 7 non-diabetic patients with PET evaluation of their MBF at the start, 30 and 220 min into dialysis with the findings of similar global reductions in MBF. The first 30 minutes of isovolemic HD was associated with a 13.5% reduction of MBF that fell further with commencement of UF to 26% by the end of HD. Similar decreases in cardiac output (CO) were noted, 21% reduction at end-HD. Two patients developed RWMA at end-HD with significantly increased reductions in MBF in these areas.[182]

These observations confirm the severity of 'cardiovascular stress' HD patients routinely undergo, during thrice weekly dialysis. They also highlight the need for a concerted effort in preserving vascular stability not only by using technologies like isothermic HD and biofeedback RBV monitoring but also by reinforcing the message about salt restriction and lower IDWGs. The adoption of more physiological therapies like long duration HD, daily nocturnal HD and alternate day in-centre dialysis will go some way in decreasing the cardiovascular stress induced by conventional HD.

1.13 Strategies to decrease the incidence of intradialytic hypotension (IDH)

1.13.1 Regular Clinical assessment

In spite of its shortcomings clinical assessment is the backbone of fluid management in haemodialysis patients. The importance of regular assessment and resetting of dry-weight cannot be over-emphasised especially during "probing for dry-weight" in the weeks following dialysis initiation, and during and after any periods of intercurrent illness. Failure to deliver this, because of insufficient resource or insufficient training, may be a major factor in the high prevalence of IDH, and a driver behind the readiness to resort to potentially helpful technologies with a relatively poor evidence base.

1.13.2 Patient education

Starting renal replacement therapy causes tremendous physical and emotional upheaval in most patients even if they had been followed up over a period of time with progressive renal dysfunction. The impact is more severe in unplanned initiations onto the dialysis programme. The change in dietary patterns forced by the loss of renal function need to be explained and reinforced by a multidisciplinary team of

physicians, nurses, dieticians and carers so as to ensure adequate blood pressure control in the interdialytic period and to minimise IDWGs. This message is largely centred around salt restriction but also is pertinent with respect to other changes in the diet to maintain other biochemical variables (phosphate, potassium, PTH, bicarbonate) within physiological targets. A <5g salt diet has a huge beneficial impact on blood pressure control.[183-185]

Food intake during dialysis can precipitate hypotension and should be avoided. Sivalingam *et al* [186;187] measured RBV, cardiac output (CO), systemic vascular resistance (SVR), ECF resistance and blood pressure in 20 non-diabetic individuals during dialysis when ingesting a standard meal 45 minutes into dialysis. The BP was significantly lower 30 minutes post-ingestion with a drop in RBV increasing the tendency for hypotension. Similar results have been reported by Shibagaki who noted a change in RBV of 14% compared to a pre-meal value of 3.2%.[188]

1.13.3 Withdrawal of antihypertensives and incremental dialysis

Phased withdrawal of antihypertensive agents and accurate monitoring of residual renal function allow the attainment of the dry weight with minimal complications. Continued monitoring of residual renal function and the provision of incremental dialysis help in tailoring UF prescriptions in line with patient's own urine output. This will decrease the incidence of symptomatic hypotension occurring as a result of over ambitious volume removal. However, it should be noted that in the first 8-12 weeks after commencement of dialysis, hypotension may frequently complicate treatments as dry weight is 'probed' and body compartment volumes return to their normal hydration state followed by a decrease in vascular tone over a prolonged period of time. (lag phenomenon)[189]

1.13.4 Other strategies

There have been numerous attempts to augment clinical management by the use of other technologies to help avoid IDH. These include relative blood pressure monitoring, bio-impedance techniques, and dialysate temperature control. These, and others are described in detail below. Other measures such as

ultrafiltration profiling, sodium profiling, dialysate calcium modification, and the use of vasoactive drugs such as midodrine, are beyond the scope of this thesis.

1.14 Residual Renal function and interdialytic weight gain

The geometric mean eGFR at dialysis initiation in haemodialysis patients in the 2008 UK Renal Registry report was 8.6 ml/min/1.73m². [190] Traditionally it has been thought that this residual renal function was lost very quickly in haemodialysis patients, in contrast to those on CAPD, though recent evidence would suggest that, at least in patients using biocompatible membranes, that the rate of loss of residual renal function is similar on the two modalities [191]. Over 30% of patients on high-flux dialysis have a significant renal urea clearance (> 1ml/min) after 5 years on the treatment. Conserved residual function of this degree is associated with improved survival in haemodialysis patients [192]. Patients with this degree of conservation of renal function tend to have good urine volumes and this makes a major contribution to maintaining salt and water balance, and significantly reduces required ultrafiltration volumes

(Figure)

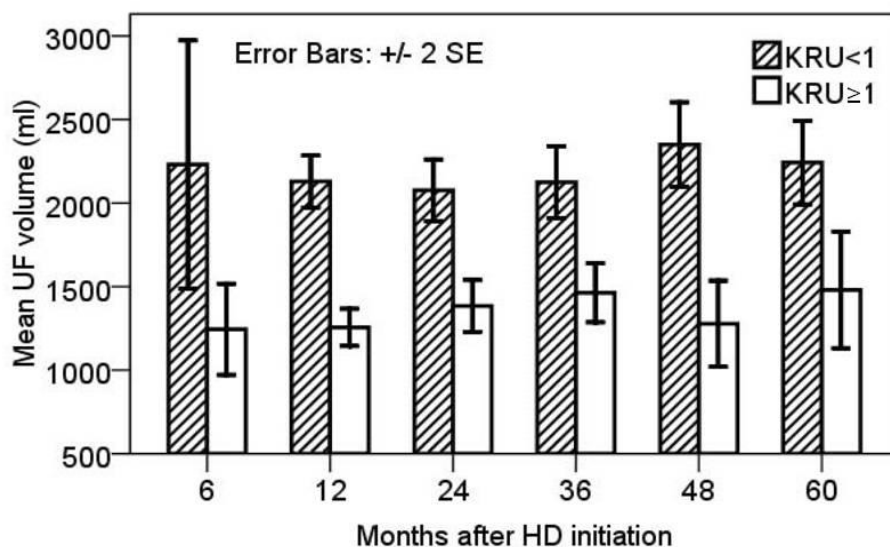

Figure: 1.2 Ultrafiltration rates according to degree of residual renal function (urea clearance [KRU]) in haemodialysis patients up to 5 years after dialysis initiation.

Urine output can be improved by use of diuretics in haemodialysis patients with preserved kidney function and there is some observational evidence of a survival benefit for this practice[193] Aggressive volume reduction in the early days of dialysis – as part of “probing for dry weight’ can have a cause a rapid loss of residual renal function[194]. Efforts should be made to conserve residual renal function though not at the expense salt and water overload.

1.15 Techniques for use in fluid management of haemodialysis patients:

1.15.1 Clinical Assessment: ‘probing for dry weight’

The term ‘dry weight’ was first used by Thomson and Waterhouse in 1967 when describing haemodialysis as a treatment for chronic renal failure[195]. Charra *et al* describe the process of establishing a dialysis patient’s dry weight to be similar to the commencement of insulin in a newly diagnosed diabetic[196]. They describe the process of ‘probing for dry weight’ in their patients as the weight reductions achieved by vigorous UF over several weeks until the BP in the interdialytic period returns to normal. This is achieved in conjunction with phased withdrawal of antihypertensive agents and continued even if intradialytic symptoms occur.

Clinical assessments also focussed on the presence or absence of peripheral oedema, pulmonary rales, degree of jugular venous distension and inter-dialytic, pre- and post-dialysis blood pressures with any postural changes. Radiographic evaluation was also carried out, mainly to assess cardiac size. The authors reported the need for an average period of 8-12 weeks during which weight reduction took place, and emphasised the need for continuing vigilance in terms of dietary restrictions and clinical assessments. This approach, though simple, is time consuming and error prone when applied to current clinical practice. Continued use of antihypertensive agents, the increasing cardiovascular comorbid load of the haemodialysis population, and the morbidity associated with high UF rates during short sessions, increase the difficulties with this trial and error approach. Hence a whole range of technologies have been evolved since the early nineties promising better accuracy, reproducibility and applicability in determination of dry weight, the potential to achieve better control of interdialytic blood pressure, and the potential to reduce intradialytic symptoms. These are briefly described below.

1.15.2 Ambulatory blood pressure monitoring (ABPM)

It is well recognised that clinic BP readings in patients with essential hypertension are significantly higher than readings obtained at home or as an ambulatory recording. Verdecchia *et al* reported ABPM readings to be an independent predictor of prognosis in essential hypertension.[197;198] They had reported a white coat hypertension in 19.5% of their hypertensive patients based on ABPM readings[198]. Similar results have been reported by Clement *et al* [199] and Bobrie *et al*[200]. In the CKD population not yet on dialysis, home blood pressure readings vary significantly from clinic recordings and higher home reading significantly predict the rate of progression to ESRD. The clinic readings are less predictive. The loss of nocturnal dipping in ABPM was also associated with a greater rate of progression to ESRD.[201]

Coomer and Schulman reported on 36 haemodialysis and 18 peritoneal dialysis patients who had undergone 48 hour ambulatory BP recordings, noting the mean systolic blood pressure (SBP) to be lower than that obtained by the nurses pre-HD (by 10mmHg). The post-HD readings were higher than that recorded in the unit (by 7 mm Hg). There was no nocturnal variation and BP four hours post-dialysis was significantly lower on the ABPM indicating perhaps the use of antihypertensive agents post-dialysis[202]. Mitra *et al* had described similar discrepancies between interdialytic ABPM measurements and those recorded in the unit. The systolic, diastolic and mean BP reading done 20 minutes post-HD correlated strongly with the mean readings obtained through ABPM. The pre-HD readings significantly overestimated the mean ABPM measurement. There were no nocturnal variations and the BP from day 2 was higher than that of day 1 perhaps indicative of ECF expansion. This is more marked in the 6 hours leading up to the next dialysis session.[203] In a controlled clinical trial, a reduction of dry weight was reflected in a significant reduction in ambulatory blood pressures[204]. In a similar study changes in home BP readings (3 times daily for 1 week) were strongly related to changes in interdialytic ABPM readings, in contrast to changes in pre- and post-dialysis readings. These findings suggest that home BP readings may have a role in dry weight assessment[205].

1.15.3 Echocardiography

Huting *et al* reported progressive cardiovascular dysfunction in a cohort of 61 normotensive ESRD patients with serial echocardiographic evaluations of the left atrial and ventricular dimensions. There was progressive left atrial enlargement, increased asymmetrical hypertrophy and increase in end-diastolic left ventricular diameter. This was proposed by the authors to be due to hypertension in the context of volume overload and presence of anaemia[206]. Similar echocardiographic evaluations at the start and 1 year into dialysis by Foley *et al* in their cohort of 227 patients showed progression to cardiac failure in 90 patients within 1 year with a further 34 showing features of cardiac failure subsequently. However improvements in LV mass index (LVMI) and fractional shortening did occur in a significant proportion of these patients, indicative of regression of LVH brought about to a significant degree by ECF volume normalisation[207]. Parfrey *et al* had earlier reported the prognostic significance of systolic blood pressure on progressive increase in LVMI in their cohort of 339 HD patients followed over many years[208]. Echocardiographic evaluations provide a useful prognostic guide to the new occurrence or worsening of pre-existing cardiac disease, but, are not practicable as a volume management tool. It is feasible to monitor left atrial diameter through serial dialysis sessions and relate the change to volume. Such associations though are tenuous and difficult to reproduce. The technique is heavily operator dependant. As a surrogate to echocardiography Doppler assessments of the inferior vena caval diameter have been widely used to assess the hydration state.

1.15.4 Assessment of the inferior venacaval diameter (IVCd)

Ando *et al* first reported the usefulness of IVCd measurement as a technique to assess the volume state in haemodialysis patients in 1985[209]. They later reported IVCd in quiet inspiration and expiration in anuric dialysis patients to be 5.7 ± 5.4 and 16.7 ± 3.2 mm respectively, also defining the collapsibility index (CI) as a ratio of the IVCd at inspiration and expiration subtracted from unity ($1 - \text{IVCd}_i/\text{IVCd}_e$). The authors proposed an end dialysis IVCd at expiration of 8 ± 3 mm as a marker of euvoemia with a corresponding CI of 0.9. Overhydration was indicated by a CI of 0.2 or less and an IVCd_e post-HD of 22mm or higher. These measurements were made using a proprietary probe patented by the investigators and therefore

were not universally applicable. [210] Cheriex and Leunissen defined CI similarly but the IVCd was normalised to the body surface area (BSA) and reported as VCD in mm/m². Through non-linear regression analysis the mean right atrial (RA) pressure could be calculated from VCD. A VCD of 11 mm/m² and a CI of >40% was taken to be indicative of normovolemia with underhydration resulting in VCD <8mm/m² and CI >75%. These values were equivalent to a RA pressure of 7mmHg and 3mmHg respectively. Of the 22 patients studied with a clinically determined dry weight, only 6 were normovolemic based on VCD. The authors achieved low intra and inter-observer variabilities (2.5% and 5% respectively) in their research laboratory[211]. Katzarski and his co-workers measured IVCd in 35 HD patients of whom 17 were hypertensive. Blood volume (BV) was measured in these patients using radio iodine labelled albumin. The hypertensive patients had larger BV and a correspondingly bigger IVCd and lower CI.[212] A variation in the US assessment of IVC diameter was proposed by Naruse *et al* called the IVC flat ratio (F-IVC). This was obtained by cross-sectional rather than sagittal measurements of the IVC diameter. The flat ratio correlated well with weight reductions[213]. Several other investigators have included IVCd measurements along with natriuretic peptide assays and echocardiography to improve the accuracy of the dry weight estimations[214-217]. The drawbacks of IVCd measurements include cost of specialist equipment, inter-observer variability and the need for the subject to wait 20-30 minutes after dialysis before measurements could be done to allow vascular refill.

1.15.5 Bioimpedance

Bioimpedance is a simple non-invasive tool to measure ECF and TBW in healthy subjects, though its utility in states of abnormal hydration remains a subject of debate. Great strides have been made in the evolution of the technique over the last two decades, as its utility has become established in the fields of nutrition, body composition, sports medicine and dialysis. There are advocates of single- and multi-frequency methodologies. Segmental methodologies of increasing levels of complexity are now becoming available for use in the dialysis setting. These technologies, in association blood volume monitoring (dual compartment monitoring), form much of the basis for this thesis. A separate introductory chapter (Chapter 3) has therefore been devoted to a description of the theory, evolution and clinical utility of bioimpedance techniques.

1.15.6 Natriuretic Peptides

ANP and BNP are the most important members of the natriuretic peptide family with an important role in volume homeostasis. Both ANP and BNP cause natriuresis and hypotension and will return volume state to normal in response to acute volume loading. In progressive renal dysfunction the levels of these peptides increase secondary to decreased urinary excretion, volume overload and cardiac dysfunction. There are suggestions that ANP changes do correlate with volume removal during haemodialysis and that BNP is an important marker of cardiac dysfunction in this population. Changes in ANP and BNP levels during the dialysis process constitute a significant part of this thesis. Hence a separate chapter (Chapter 4) has been devoted to a description of the biochemistry and clinical utility of Natriuretic peptides with special reference to the dialysis population.

1.15.7 Blood volume monitoring:

1.15.7.1 Absolute Blood Volume (ABV):

ABV measurements are difficult to adopt into clinical practice. These require radioactive tagging of either the red cells or the plasma protein components, usually albumin. I¹³¹ labelled albumin has been used by Katzarski and his colleagues in 16 haemodialysis patients whilst validating the usefulness of IVCd as a volume marker[212]. BV values obtained from 35 healthy volunteers was used for comparison.

Indocyanine green (ICG) can also be used to measure blood volume and has the added advantage that the substance is not radioactive. Mitra *et al* used ICG with its adsorption peak at 805nm, to serially determine plasma volume (PV) and then the BV based on haematocrit measurements. The dye is non-toxic, highly protein bound, hepatically excreted and has an elimination half life of 2-3 minutes. Ten mg of the dye was injected into the venous port followed 3 minutes later by sampling from the arterial port at one minute intervals. The study was done during a period of isovolemic dialysis to ascertain reproducibility and also during a complete dialysis session when UF was done in pulses. The isovolemic PV measurements showed excellent reproducibility ($r^2 = 0.98$, method SD 356 ml, coefficient of variability 4.07%) and a difference of only 149 ± 341 ml (mean \pm SD) when compared with predialysis PV values (before commencement of isovolemic dialysis). This method could potentially be used repeatedly during dialysis

to measure BV. However the need for a specialist substance, compatible equipment to read the decay characteristics and the time involved makes this technique more of a robust research tool[218].

1.15.7.2 Relative Blood Volume (RBV) monitoring:

RBV monitoring was developed as a tool to reduce the incidence of intra-dialytic symptoms consequent to hypotension resulting from UF rates that exceed the rate of vascular refill. The principle behind the technique is the continuous measurement of an intrinsic property of blood such as the mass density, viscosity, electrical conductivity, optical density or haemoglobin concentration and the relation of changes in these parameters at any given time during UF to that at the start of the session. A considerable body of experience has accumulated on the utility of this technique in the haemodialysis population. RBV monitoring forms an important part of the dual compartment monitoring described in this thesis. A separate chapter has therefore been dedicated to a description of this technique and it's clinical utility.

Chapter 2

Dialysis Machine Functions and Volume Management

1. Relative Blood Volume Monitoring
2. Dialysis fluid temperature control
3. Ultrafiltration profiling and sodium profiling

2.1 Introduction

Haemodialysis machines are increasing in sophistication. Many modern machines have a range of functions which may be of potential benefit in the management of volume in every day clinical practice. These include relative blood volume monitoring, dialysate temperature control, ultrafiltration modelling, and sodium modelling. This chapter will explore the potential usage of these techniques in clinical situations.

2.2 Relative blood volume monitoring (RBV)

2.2.1 Principles and Development

Blood volume monitoring has been in use for over 15 years in dialysis practice as a potential tool to aid achievement of dry weight and also to reduce the incidence of intradialytic hypotension (IDH). Stiller and his colleagues described the technique of continuous measurements of haemoglobin concentrations in 20 HD patients over 50 sessions[219]. The changes in haemoglobin concentration in response to the UF rate was taken to be the fractional change in blood volume. Schneditz *et al* developed a similar technique measuring the changes in total protein concentration (TPC) during dialysis using a sound sensor that was later modified to produce the Fresenius BVM (blood volume monitor)[220]. The optical method of monitoring changes in haematocrit was proposed independently by de Vries's[221] group in Netherlands and Steuer[222] and colleagues in USA measuring the optical absorbance of monochromatic light continuously.

The principle behind the technique is that of mass conservation. The concentration of constituents of blood confined to the vascular compartment will proportionately change as the plasma volume decreases with UF. The technique makes two assumptions- the total amount of the measured constituent should remain constant and there should be uniform mixing of the measured constituent in all regions of the vascular bed. These assumptions will be examined in detail in a subsequent section.

The fundamental equation in any RBV technique is:

$$\text{RBV change (in \%)} = [(C_0/C_t) - 1] \times 100,$$

where C_0 and C_t represent the concentration of the constituent that is studied at start of UF and at time 't'.

There are currently at least three available devices to measure RBV:

- Fresenius BVM using an ultrasonic method
- Hemoscan using the optical method,
- Crit Line® using optical methods [this is a stand alone device].

These deploy one of two strategies. The first measures changes in haemoglobin (Hb) or haematocrit (Hct) concentration by determining the optical absorbance of monochromatic light (Crit Line and Hemoscan). The second method measures changes in sound velocity as concentration of total protein changes with loss of plasma volume. Both exhibit high coefficients of correlation with laboratory reference methods for Hb/Hct and total protein estimations (0.99 and >0.88 respectively)

2.22 Clinical utility

RBV monitoring has been shown to predict the onset of IDH by various groups during the early evolution of the technique[223-225] (Kim et al, De Vries et al and Steuer et al) though subsequent work by various other investigators has posed some additional questions.

Steuer *et al* had been involved in the development of the optical device measuring changes in haematocrit in 1993-1994 and described the use of this device in predicting intradialytic morbid events (IMEs) including IDH, cramps and lightheadedness in 16 patients over 93 sessions. IMEs occurred in 48 sessions and the investigators described the occurrence of events at a threshold haematocrit in 12 of the 16 patients.

In addition, the rate of change of RBV was higher in sessions complicated by an IME than that where BP was maintained throughout (12.2 ± 5.5 vs 5.6 ± 3.6 %/hr). Lastly there was no reproducible

relationship between mean arterial pressure (MAP) and change in haematocrit in most of the patients. The authors proposed a threshold haematocrit that they termed 'crash crit' above which IMEs occurred in most of their patients. It was also suggested that the rate of change of RBV should not exceed 8%/hr in hyopotension prone patients and the UF rate altered to prevent reaching this RBV threshold[224]. The 'crash crit' has not been reproduced consistently in other studies.

The concept of tailoring the UF rate to changes in RBV by a closed loop biofeedback control system was developed by Zucchelli's group in 1998. The dependant variable was RBV change and the two independent control variables were UF rate and dialysate conductivity (DC). Eight highly symptomatic patients were assessed in a crossover study for improved haemodynamic tolerance in the biofeedback model (BV-CHD) versus the a conventional HD (CHD) session. Each patient was studied for 36 consecutive sessions, first 12 being CHD (A1), second being BV-CHD (B) and the last CHD again (A2). The authors defined a RBV trajectory for each of these patients that was then obtained by changes to the UF rate and DC. The ideal RBV trajectory was defined to be one where the RBV variability was minimal towards the second half of the session and a resultant smooth decline in the RBV slope. The total UF volumes were identical during both BV-CHD and the CHD sessions with an identical mean DC of $14.2 \pm 0.3\text{mS/cm}$. The RBV decline was lower in the BV-CHD group though the difference did not reach statistical significance. (-10.6 ± 1.6 vs $-12.3 \pm 3.1\%$). However the systolic arterial pressure (SAP) declined significantly less during the BV-CHD compared to the CHD phase indicating better haemodynamic stability. The number of IDH episodes were 3 severe and 22 minor in the BV-CHD phase compared with 26 severe and 16 minor in the CHD phase ($p < 0.05$). The biofeedback model was successful in converting many potential severe IDH episodes into minor ones by the rapid institution of both a change in rate of UF and DC. The authors allude to the addition of the DC model as the reason for better tolerance while achieving identical weight losses that were identical in A1, B and A2 phases[226].

A mathematical model of RBV change during dialysis and relating the variability of the RBV curve from a linear regression line to the onset of IDH was described by Beige's group in Germany[227]. One hundred and fifty eight patients were monitored over 380 treatments in a supine position with a constant UF rate. Critline instrument was used to monitor RBV changes. An aquisition resolution of 20 sec was achieved

and the RBV change in response to UF was plotted against dialysis time to generate the RBV curves. A linear fit was performed and the variability of the curve from this linear fit was defined mathematically as 'long term variability index' and the standard error of the RBV data points from that calculated through the 'linear fit equation' was defined as the 'short term variability index'; a measure of a goodness of fit but in short time segments. (figure 2.1) Both these indices were dimensionless numbers. The slope of RBV reduction was calculated over the whole period and also during short time segments.

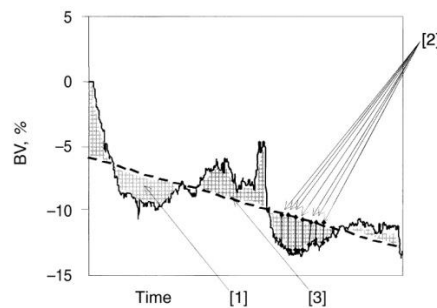

Figure 2.1

Illustration of the investigated indices. (1) "Long-term" variability, defined as the area between the blood volume (BV) curve and linear regression line. (2) "Short-term" variability, defined as the mean deviation of BV values from linear regression line. (3) Slope of the linear regression line
(Reproduced with permission from *Beige et al Kidney International, Vol. 58 (2000), pp. 1805–1809*)

Forty six episodes of IDH occurred and 10 minutes before the onset, the long and short term variability indices were at their lowest, sessions complicated by IDH also showed lower overall values of the long-term variability index. There was also a decrease in the slope of the RBV curve prior to the occurrence of an IDH episode. The investigators speculated an increased incidence of IDH when the long-term variability index was below 16. This was the first attempt to define the RBV decay as a mathematical construct and relate it to a clinical occurrence. The model was complicated and required specialist understanding to calculate the indices and the authors commented that using these indices as measures of variability was speculative. Nevertheless, the authors felt that, there were changes in 'patterns' in the RBC curve in sessions complicated by IDH that were deemed suitable to explore to develop a biofeedback model coupling UF rates with RBV decay.

Mitra *et al* [228] defined the RBV changes to UF pulses in thirty dialysis patients monitored over a single session. UF pulses were applied to remove 40% IDWG in the first 30 minutes of the session followed by

a 20-30min isovolemic dialysis and further three pulses removing 20% of IDWG each with isovolemic dialysis for a short duration separating these pulses. If hypotension had not occurred following these three pulses further UF pulses were applied of equal volume until hypotension ensued. The RBV profiles during these UF pulses (not the first pulse removing 40% IDWG) were fitted to an exponential curve defined by the equation

$$y = b * e^{-\frac{x}{c}}$$

Where 'c' was defined as the UF decay constant (τ_{UF}) and 'b' the UF decay amplitude.

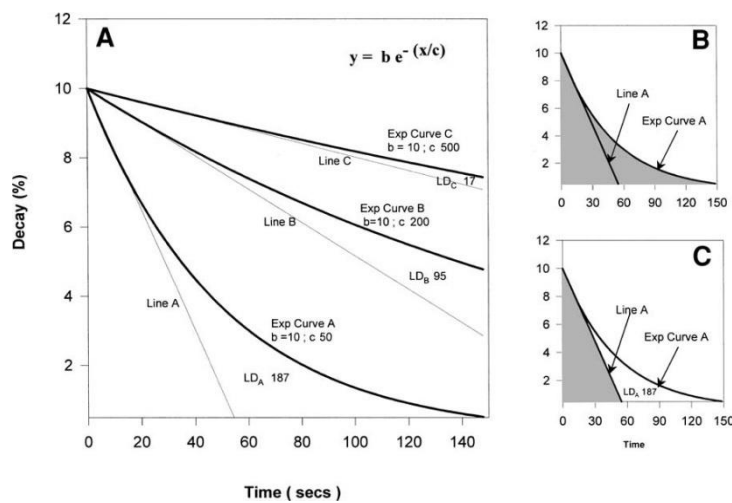

Figure 2.2

(A) Simulation of the single exponential $[y = b e^{-\frac{x}{c}}]$ decays (Exp curves A, B, and C) with identical coefficient $[b=10]$ and varying decay constant (c). Equivalent parameters on UF-induced exponential decay curves are $c = \tau_{UF}$ and $b = \text{UF decay amplitude}$. Lines A, B, and C represent predicted linear decay for each curve. Linear divergence (LD, %s) represents the integrated area between exponential and linear decay for each curve. Exp curve C is defined by a higher c (T) and diminishing linear divergence. (B, C) Demonstration of the derivation of LD for Exp curve A. LD is the difference between integrated areas under the Exp curve A (B; shaded area) and Line A (C; shaded area). (Reproduced with permission from *Mitra et al American Journal of Kidney Diseases*, Vol 40, No 3 (September), 2002: pp 556-565)

The first minute of the RBV curve corresponding to each of the UF pulses was then analysed and curve fitted to represent a linear decay. The RBV trace corresponding to successive UF pulses approached linearity with the area between the obtained RBV trace and the extrapolated linear decay becoming smaller in subsequent pulses until linearity is approached. This approaching linearity as UF pulses are applied removing more and more volume correlates well with the onset of IDH and the limit of UF for that session. The author describes this approaching linearity as a switch from two pool to single pool kinetics as refill from the interstitium to the blood volume diminishes as target weight is approached. In

contrast to the method of Beige *et al* where a linear regression was applied to the whole RBV curve encompassing the full session with a constant UF. Mitra *et al* characterised a short segment of the RBV change that was amplified by the adoption of an UF pulse. The time segment was sufficiently short to allow the extrapolation of a linear decay onto the whole of the trace. This then enabled the recognition of a trace transformation (from exponential to linear) over successive UF pulses and inferences relating to the proximity of target weight and the risk of impending hypotension should UF continue. In patients whose RBV trace continued in an exponential trajectory, continued UF would be appropriate.

Continuing on the theme of RBV trace characterisation, Andrulli *et al* [229] in 2002 reported on their cohort of 123 HD patients, stratified into normotensive (A, n = 32), hypotension prone (B, n = 25) and hypertensive (C, n = 66) groups with their RBV profiles probed for markers for the onset of IDH. The RBV profiles were labelled as flat, linear decrease, concave upwards decrease, concave downwards decrease, regular and irregular line. BP and heart rate (HR) were recorded every 20 minutes. Sodium balance was also measured. There were subtle differences in the composition of the groups with group B having more elderly and more diabetic patients, group C more women and lower mean weight significantly to that seen in Group A. The degree of RBV reduction was identical ($-13.8 \pm 7\%$) in all three groups. In the hypotension prone group no significant differences were demonstrated in intradialytic RBV change between asymptomatic sessions and those complicated by IDH ($-13.9 \pm 6.4\%$ vs $12.7 \pm 5.2\%$). Predictors of IDH were the rate of decrease of RBV at between the 20th and 40th minute after start of dialysis, an associated irregularity of the trace, a larger sodium gradient and a lower heart rate decrease in the first 20 minutes of dialysis. A concave upwards RBV profile was also thought to be indicative of poor vascular refill and hence more frequently associated with hypotension.

Vascular refill characteristics were studied with a Critline monitor in 28 haemodialysis patients by Rodriguez and his colleagues [230]. The study was performed in three phases. In Phase 1, the refill characteristics were defined, in the second phase the RBV trace during dialysis was correlated with refill characteristics and in the third phase interventions were carried out to achieve optimal dry weight. The RBV profiles from phase 2 led to the identification of three patterns; first with intradialytic reduction in RBV but no post-dialysis vascular refill, second with intra-dialytic RBV reduction and post-dialysis

vascular refill and third with no change in RBV throughout dialysis. In phase 3, an UF protocol for blood volume reduction was adopted with post-dialytic vascular refill monitoring. Simultaneous clinical assessments of the hydration status and evaluation of post-dialysis fatigue helped in adjusting the dry weight downwards in many instances at the same time enabling the detection of underhydration in a few instances with revision of weight upwards. The approach was simple and did not require sophisticated algorithms to interpret RBV changes and may yet be the most useful way of applying the technique to assess fluid status.

Randomised control trials comparing the usefulness of RBV monitoring have been lacking, until the results from the CLIMB study (CritLine for intradialytic Monitoring Benefit) published in 2005[231]. The authors tested the hypothesis that RBV monitoring would improve fluid removal thereby reducing mortality. The trial recruited 227 patients to the Critline limb and 216 to the conventional monitoring limb. Set algorithms for fluid removal based on Critline trends of RBV decline were provided to all personnel across the 6 participating centres. The study ran for 6 months and the primary outcome was the rate of non-access related hospitalisations.

The Critline limb had a significantly higher non-access related admissions (120 vs 81; RR 1.49; $p = 0.017$; CI 1.07 to 2.08) and the authors reported rather surprisingly that the RR achieved statistical significance only for non-cardiac reasons for hospitalisations when the non-access related admissions were split into cardiac and non-cardiac. The incidence of IDH reported as number of episodes divided by the number of patient-days at risk were exactly the same between groups (0.07) and the frequency of symptoms of hypotension again were identical. (0.11). It was concluded that intensive monitoring and reacting to changes in the RBV trend could be detrimental and do not really improve the intra-dialytic haemodynamic stability. Intriguingly there was also excess mortality in the intervention group (8.7% vs 3.3%, $p = 0.021$). The cause for such an increase in mortality by application of an extracorporeal monitoring technique is difficult to understand, it should be noted though that mortality in the control group was very low. Nevertheless, the results do not support systematic increases in UF volumes in the Critline group. There was no overt evidence to indicate that care may have been compromised by the distraction of Critline monitoring and there was no construct available to analyse any systematic

differences in care provided between groups. It is feasible that missing data regarding RBV decays in a significant number of patients and relatively relaxed enforcement of the algorithm may have coloured the interpretation of UF trends and if available or algorithm stringently enforced the cause for such a significant difference in outcomes could have been more clear. Furthermore lack of a systematic enrollment approach to identify and include patients with specific volume management issues or stratification based on specific clinical correlates compromising volume removal may have accounted for such a difference in survival between groups. Whilst the CLIMB study was not designed to impact on the incidence of IDH, it however illustrated the lack of discernible trends in the RBV decay predicting the onset of IDH.

In one of the earliest studies of blood volume monitoring during dialysis, Lopot *et al* commented on the patterns of decay in 66 HD patients describing a linear decay in blood volume curve in 33 patients, no decrease in BV in 21 patients and a plateau response in 11 where the blood volume remained unchanged for a variable length of time before decreasing[232]. Whole body bioimpedance and IVCd was used to adjust the dry weight in each of the three groups. The authors commented on the possible role of BV monitoring in identifying hypervolemia in prevalent patients and also its potential usefulness in UF volume prescriptions to prevent hypotension during dialysis.

2.23 Biofeedback Techniques - Blood Volume Tracking (BVT)

As mentioned previously, a biofeedback device tracking the RBV change along a pre-determined trajectory by varying the UF rates and DC provides better haemodynamic stability by ‘ironing out’ sudden drops and variations in the RBV trace. The percentage change in RBV in the biofeedback model was lower than conventional HD though this did not reach statistical significance (only 8 patients studied) [233]. Ronco *et al* found similar haemodynamic stability by instituting acetate free biofiltration coupled with a biofeedback system adjusting UF rates and DC continuously in response to the rate of RBV reductions[234]. Nineteen hypotension prone patients were studied by Carlo Basile’s group in Italy using the same system of Santoro *et al* over shorter and medium term with markedly decreased IDH and hypotensive symptoms when dialysing with the biofeedback model. A higher $\Delta\text{RBV}/\Delta\text{ECF}$ ratio was

obtained when dialysing with the BVT indicating better preservation of vascular refill [235]. Franssen *et al* used the technique and described post-HD blood pressure improvements in hypotension prone patients (n =12), though, evident only on ABPM [236]. A less well reported biofeedback system is based on the original concept of ‘crash crit’ with UF rates programmed to stop if a preset haematocrit is reached. The preset haematocrit is decided in a run in period with a clinically determined dry weight[237][238].

A case was made for a ‘crash crit’ based biofeedback system by Kraemer *et al* [239]when they noted an absence of relationship between slope of the RBV curve and the onset of hypotension. The conclusion therefore was that a critical RBV threshold preceding hypotension did not exist in all patients (only 12 out of 18 patients had a critical RBV threshold in the study) and biofeedback control of UF may be beneficial. Barth *et al* tested the premise that a critical RBV threshold did exist for most HD patients by observing trends in 60 HD patients and noting that the SD of the critical RBV threshold was <5% in 45 of the study patients. The SD of the critical RBV in 21 out of these 45 patients was closer to 4% implying that in 30-35% instances these patients will not exhibit changes in BP heralding IDH if purely a critical RBV threshold criteria is used[240].

2.24 Limitations of RBV monitoring:

2.241 Disparity between ABV and RBV

RBV monitoring is a technique limited to measuring hydration changes in the intravascular bed by using a surrogate marker- total protein (TP), Hb or Hct. Extrapolating the changes to ABV can often be quite erroneous. The intravascular compartment emptying during dialysis is offset by fluid shift from the ECF. The efficiency of this vascular refill will determine the presence or absence of disparity between RBV changes during dialysis and the corresponding changes in ABV. Overhydration will be associated with an expanded ECF and reflects as an increase in ABV. Assuming this excess fluid is removed completely during dialysis, the magnitude of change in RBV in this instance will be greater to reach the same post-HD ABV compared to a situation in which there is a lesser degree of initial fluid overload. If a critical RBV threshold method is deployed, there is a danger that the post-HD ABV will remain higher leading to persistent hypervolemia and an erroneous dry weight. Simultaneous comparison of changes in RBV and

ABV (indocyanine green method, Mitra *et al* [218]; radioiodine labelled albumin or Cr-labelled RBCs) will clarify the relationship further.(see below)

Such an attempt was successfully made by Dasselaar's group in Netherlands and published in 2007[241]. ABV was measured during a dialysis session with ^{125}I labelled albumin for plasma volume and ^{51}Cr labelled erythrocytes for the RBC fraction. In addition, to measure transcapillary leakage of albumin another dose of ^{125}I albumin was administered at 180min into dialysis. Subjects were stable HD patients without diabetes, dialysing through an AVF with no recirculation and not diabetic. The UF volume was $2450 \pm 770\text{ml}$; ABV declined from $5905 \pm 824 \text{ ml}$ to $4877 \pm 722 \text{ ml}$, a percentage reduction of 17.3 ± 4.4 compared to a ΔRBV of 8.2 ± 3.7 ($p = 0.001$) indicative of a gross underestimation of ABV change by relative blood volume monitoring.

2.242 Fahraeus effect and altered F_c ratio

The haematocrit (Hct) measured in the arterial or venous blood is not the same as the total body Hct. This is called the Fahraeus effect (1929)[242]. If whole blood is allowed to flow from a large reservoir into a small circular cylindrical tube, the hematocrit in the tube is less than that in the reservoir, and the smaller the tube, the smaller will be the tube hematocrit. This is a feature of particulate flow and occurs in the microvasculature $<200 \mu\text{m}$ in diameter. The ratio of the whole body Hct (lower) to that of the arterial or venous Hct is called the F cell ratio (F_c) and is 0.91 in healthy state. The relationship between whole body Hct and arterial/venous Hct does not remain constant during dialysis and UF. The movement of low Hct blood from the microvasculature into the intravascular compartment as a compensatory mechanism to maintain pre-load means the RBV measurements based on the principal of mass conservation are no longer valid. Mitra *et al* and Dasselaar *et al* report a rise in F_c as UF continued with increases from a baseline of 0.87 to 0.94 and 0.896 to 0.993 respectively. This then adversely affects the accuracy of RBV monitoring systematically underestimating the volume change[241].

2.243 Postural changes during HD

The assumption of a sitting or semi reclining position at the start of a HD session after a period of standing can cause changes in Hct that could be misinterpreted as change brought about by the discrepancy between UF and vascular refill. Standing causes a relative increase in Hct as plasma gravitates towards the interstitial space, both in healthy individuals and dialysis subjects. Assumption of the supine position after a period of standing allows for the mixing of Hct in various circulatory beds causing a real rise in Hct followed by a fall as plasma mobilises from the tissues into the circulation. This mixing can take as long as 30min in the dialysis population and commencement of RBV monitoring whilst this is happening will result in an erroneously high Hct as the starting point.

2.244 Exercise and food intake

Food intake causes a drop in RBV as mentioned previously. Intradialytic exercise also causes a reduction in RBV due to a complex interaction between the interstitium. Microvasculature, cardiac output changes and changes in peripheral vascular resistance. The result is mostly beneficial in terms of haemodynamic stability

2.245 Refill from splanchnic circulation

Towards the latter third of HD it is often the case that volume recruitment occurs from the splanchnic beds to maintain vascular stability and splenic contraction in particular can flood RBC rich blood into the circulation. This may be interpreted as a decrease in RBV by the device whereas in reality the volume has increased.

2.246 Other Issues

Albumin infusions and blood transfusions will both be interpreted as a decrease by the device. Changes in the RBC volume may also occur during sodium profiling or with the use of hypotonic or hypertonic dialysate. [243;244]

2.3 Control of dialysate temperature

2.31 Clinical Studies

The influence of dialysate temperature (T) on vascular stability has long been recognised. Maggiore et al described better haemodynamic profiles in patients whose extracorporeal circuit was actively cooled to 35°C compared to when it was 37 °C[245]. Similar beneficial effects were observed by the same authors in different clinical situations including haemofiltration, isolated ultrafiltration and during extracorporeal therapies used for treating ARF. Heat transfer from the dialysate to blood was observed in these studies when the T was set at 38 °C. Preventing this heat transfer still resulted in an increase in the core temperature (CT) not abolished by aspirin infusion arguing against a pyrogen hypothesis. Active cooling was considered an important measure to preserve cardiovascular stability[246-248].

Orofino *et al* tested this hypothesis in 60 patients followed up over 12 months over 7742 dialysis sessions with half the sessions done with a T of 37°C and the other half at 35°C. The incidence of systolic hypotension (SH) marginally decreased from 16.4 to 14.3%. In 12 patients with SH >30% in their higher T sessions had their hypotensive episodes reduced from 44.2 to 34.1% when dialysing with a cooler dialysate. A T of 36°C was suggested as standard dialysis prescription[249]. Lindholm's group measured, in 8 hypotension prone patients, the temperature of the blood at the arterial and venous blood lines as well as that of the dialysate at the inlet/outlet of the dialyser. The mean temperature of the arterial blood at the commencement of dialysis was 35.7°C. T was altered to change the temperature at the venous blood line to 37, 36 and 35°C for two dialysis sessions each. The heart rate and mean arterial pressure (MAP) increased and decreased respectively at venous temperatures of 36 and 37°C but remained stable at 35°C. This probably represents the first attempt at an isothermic dialysis.[250]

Sherman and colleagues conducted a randomised trial studying the effects of T's of 35.6, 36.7 and 37.8°C in 17 patients over 150 dialysis sessions. More hypotensive episodes occurred during 37.8°C dialysis with better BP preservation at 35.6°C. When a subset of patients (n = 7) experiencing frequent IDH were studied with even cooler dialysate (34.4°C) the incidence of hypotension decreased from 0.58 to 0.05 episodes per session. The use of a T about 1°C lower than the 'isothermic' was proposed[251]. A similar conclusion was reached by Jost and Agarwal in their randomised study comparing 35 and 37°C in 6 hypotension prone and 6 other patients with large interdialytic weight gains. The beneficial response was thought to be a result of increased peripheral vascular resistance mediated via the efferent sympathetic

nervous system.[252] Increased LV contractility during cooler dialysis was demonstrated by Levy and her colleagues in 6 stable HD patients before and after 37 and 35°C dialysis[253]. In another study, decreases in cardiac output, which were disproportionate to those brought about by changes in blood volume, were observed in 7 patients who showed a 25% or greater drop in MAP when dialysing with a T of 37°C. When these patients were switched to 'cooler' dialysis the decrease in MAP was significantly reduced, the stroke volume increased and peripheral vascular resistance increased dramatically. The latter effect was responsible for central shunting of blood from low resistance vascular beds[254].

The cooler dialysis referred to by various investigators is somewhat ambiguous as one needs to know the degree of cooling offered by measuring the core temperature (CT) of patients. It is well known that ESRD is associated with poor thermoregulation and accompanying comorbidities and autonomic dysfunction will further hamper adaptive mechanisms. In one of the earliest studies involving a larger cohort of patients, Fine and Penner, clearly illustrated the variations in CT of 128 dialysis patients[255]. Twenty nine patients had temperatures <36 (hypothermic) while 48 had temperatures >36.5°C (euthermic); these two groups were monitored through a cross over study. Patients whose temperatures ranged between 36-36.5°C were not studied. The T compared was 37 versus 35°C. Each patients was observed over 30 dialysis sessions, of which 10 were at 37°C followed by 10 at 35°C and 10 sessions back at 37°C (ABA), in the second study the sequence was reversed. (BAB) There were in total 1662 37°C treatments compared with 893 at 36°C. A ABAB/BABA scheme was designed at the start, but patients refused to go back to 35°C for a second time because of the increased coldness felt at the lower temperature. The group designated hypothermic, not surprisingly had a 16% incidence of SH during 37°C dialysis in comparison with 3.4% during 35°C. The incidence of SH did not differ significantly in euthermic patients between the two treatments. (7.4 vs 7%). The investigators highlighted the variations in body temperatures of dialysis patients and similar variations in CT have been reported by Pizzarelli and others[256]. The beneficial effect of cooling is more pronounced in the cohort with lower CTs than those without. However patients often complain of feeling bitterly cold and variations in the ambient temperatures may exacerbate this.

The aforementioned studies espouse the benefits of low temperature dialysis. The physiological basis of this beneficial effect has been proposed to be the ability of a lower T to offset the tendency for CT increase that accompanies UF. Decreasing blood and TBW volume is associated with increasing heart rate as mentioned previously and a consequent increase in metabolic rate. Coupled with cutaneous vasoconstriction the capacity for heat loss is substantially decreased causing rises in CT. [257] If inappropriately higher T is used heat transfer to the patient also occurs destabilising the BP.

Whilst dialysis with UF results in a rise in CT, compromising vascular stability, haemofiltration (HF) usually is a better tolerated modality thought to be due to increased extracorporeal circuit heat loss, convective versus diffusive clearance and lower UF and blood flow rates. Maggiore's group speculated that if heat losses during HD with UF[247] were made similar to that during HF, then changes in MAP would be identical. A similar improved tolerance is observed for haemodiafiltration (HDF). Movilli's group studied 12 patients who underwent standard bicarbonate HD for 6 months followed by either pre-dilutional HDF or acetate free biofiltration (AFB) for 12 months. There was a modest but significant reduction in the incidence of hypotensive episodes[258]. The Italian Cooperative Dialysis Study Group compared various modalities of dialysis and did not find significant differences in the incidence of hypotension. It should be mentioned that the incidence of hypotension was very low through the whole study period[259].

Karamperis *et al* came to contrary conclusions when they studied 12 patients during a session of pre-dilutional HDF (infusion rate 1.2L/kg/session) and a session of low flux HD of 4.5 hours duration. The CT was kept constant by varying the T. No haemodynamic differences were demonstrable with similar energy changes during both treatments[260]. As stable patients were studied it is difficult to completely discount beneficial effects of HDF. This was demonstrated by Donauer and his group studying 17 hypotension prone HD patients for 25 sessions each with constant T and post-dilutional HDF (o-HDF). In the second part of the study o-HDF was compared with HD and the T was altered to achieve the same energy flow rate (Temp-HD) as that of o-HDF. Symptomatic hypotension occurred at a rate of 40% of sessions in the HD sequence whereas only 4% during o-HDF. There was active cooling of both the extracorporeal blood and CT during o-HDF. When energy transfer rates were matched there was no

difference in the incidence of hypotension between o-HDF and Temp-HD[261]. Karel Leunissen's group in Netherlands described exactly similar results in their 11 patients dialysed conventionally (UF + HD) at T of 37°C, HF at 36°C (pre-dilution) and HF with infusate warmed to 39°C (warm-HF) on successive dialysis sessions. Changes in the extracorporeal venous and arterial temperatures were identical in UF+HD and warm-HF whilst HF at 36°C was associated with best haemodynamic profiles. The investigators used innovative technology- strain gauge plethysmography- to measure forearm vascular reactivity (FVR) as a marker of improved vascular stability in addition to the conventional parameters of MAP and symptoms of IDH[262]. The same group went further comparing the effect of the infusate rate (1 vs 2.5 L/hr) in post-dilutional HF on blood pressure and energy parameters. The energy removed during the 2.5L/hr infusate was comparable to that during conventional HD at 35.5 °C making the authors conclude that the better stability of HF can be matched by cooler T dialysis[263].

2.32 Development of the Fresenius BTM®

Maggiore's work recognising the importance of heat transfer as a factor predisposing to arterial hypotension in 1981 provided the impetus for the development of the patented blood temperature monitoring (BTM) technology[264]. Hans-Dietrich Polaschegg, the head of the R&D department of Fresenius, that was then a small dialysis equipment manufacturer, filed the first patent for the BTM in 1986[265]. The technology was then integrated into dialysis delivery systems and became available from 1988 ushering in a new era in the understanding of thermal changes during dialysis beyond just temperature measurements. BTM could also, non-invasively, measure access recirculation.

2.33 IDH and extracorporeal energy transfer

Provenzano *et al* [266] first quantified energy changes using an early version of the BTM during 37°C and 34°C T reporting a gain in energy at the rate of 83 ± 61 cal/min during the former compared with an energy loss at a rate of 463 ± 121 cal/min during the latter session. Kramer and Polaschegg reported on the ability of the BTM module to measure energy changes during dialysis in 1992, when the module was able to be integrated into dialysis delivery systems[267]. Further progress was made by Schneditz's group, when they compared two pre-set levels of energy loss (-13.4 vs -30.2 W, per session) during two dialysis

sessions in 8 patients using the BTM and correlated the equivalent T as 37.3 and 35.3°C respectively. The session with the higher energy loss was associated with a significantly larger RBV change (-12.8 vs -7.2), a drop in core temperature compared to a rise (-0.1 vs +0.4°C) and a better preservation of BP inspite of the larger decrease in RBV[268].

A similar attempt by Kooman's group in Netherlands measuring energy changes in nine patients dialysing at 37.5°C (warm) and 35.5°C (cool) found 3 times as much energy being removed during the cool dialysis (-7 vs -22.7 W) and preservation of the core temperature. Even though the T was almost identical (37.3 vs 35.3 in Schneditz *et al* and 37.5 vs 35.5 in van der Sande *et al*) in both these studies the energy changes were different for broadly similar weight losses but differing UF rates[269].

The tendency for the CT to rise inspite of energy removal from the body lends credibility to Gotch's volume hypothesis of heat accumulation with UF[257]. Rosales *et al* elegantly proved the association between UF and CT change by maintaining the CT constant during dialysis and measuring the energy needed to be removed to achieve this. This was facilitated by the 'T-control' mode of the BTM that varied the dialysate temperature to keep the CT constant (isothermic dialysis). Twenty seven patients were studied over 51 treatments, extracorporeal heat flow was 17 ± 6 W, energy expenditure (H) from anthropometric data was 65 ± 12 W, $28 \pm 10\%$ of energy expenditure (H%) was removed during isothermic dialysis. The percentage weight loss was $4.8 \pm 1.4\%$ (W%). There was a tight correlation between H% and W% indicating the need to remove a bigger fraction of energy if IDWGs were larger to maintain the CT constant. For every percentage of body weight decrease (by UF) 6% of H needed to be removed through the extracorporeal circuit. The T cooled from 35.9 ± 0.3 to 35.6 ± 0.6 °C[270].

The role of isothermic dialysis in maintaining vascular stability in hypotension prone patients was examined in a randomised control trial across 9 European countries in 27 centres (Study Group of Thermal Balance and Vascular Stability). IDH was rigorously defined and 116 patients were identified to take part, 95 completed the study. Patients were their own controls. A screening period of one month was spent collecting data on hypotensive episodes, with patients being recruited if they had 3 or more hypotensive episodes during the 12 monitored dialysis sessions. Two interventions were chosen,

isothermic HD (HD_{iso}) where the CT is kept constant by energy removal and thermoneutral HD (HD_{therm}) where the energy flow in the extracorporeal circuit is zero. Each intervention was carried out for 4 weeks, one half of patients were randomised in an (A-B) fashion with the other half doing the reverse (B-A). A 1 week run in period on standard HD was done preceding randomisation. The median number of sessions complicated by IDH reduced from 6 to 3 in the HD_{iso} phase of the study ($p < 0.001$ when compared with HD_{therm}). Sixty six out of 95 patients experienced lower number of IDH episodes when on HD_{iso} . During HD_{therm} the median IDH episodes remained almost identical (6) to that observed during the standard HD session. The arterial and venous temperatures increased along with an increase in T during HD_{therm} whereas the arterial temperature remained the same with both the venous and T reducing through the duration of the session in the HD_{iso} phase. Blood pressure reductions were more obvious from the 90th minute into dialysis and were significantly higher for HD_{therm} than for HD_{iso} . The application of a feedback system to cool the dialysate as required rather than setting an arbitrary 'cool' temperature for the entire session meant the sessions were better tolerated. The nadir T in the HD_{iso} was a more modest 35.7°C and the exposure was limited to towards the end of dialysis when the risk of IDH was at its highest. Similarly during HD_{therm} the T rose but to a modest 37.5°C and obviously not for the entire duration of the session with the average T being 37.3°C. The rationale of comparing HD_{iso} with HD_{therm} , the latter being an intervention resulting in a rise in CT, rather than evaluating against conventional HD of say a T of 37°C was justified by the fact that a conventional HD would cause variable energy changes through the extracorporeal circuit in different patients whereas HD_{therm} was an uniform intervention of zero change. This trial remains an important milestone in the implementation of BTM to reduce IDH with an unambiguous demonstration of the importance of maintaining CT constant during dialysis[271].

A systematic review of the benefits of lowering the dialysate temperature by Selby and McIntyre showed 22 studies comprising 408 patients; 16 studies studied the effect of an empirical 'cool' T while 6 used BTM biofeedback to control CT; all were cross over studies but were of short duration. IDH occurred 7.1 times less frequently with the use of a cooler dialysate (both empirical and BTM controlled), post-dialysis MAP was 11.3 mm Hg higher and there were no compromises in dialysis adequacies when cooler

dialysate was used. The symptoms relating to cooling were poorly reported in most of these studies[272]. KDOQI in 1997 advocated lowering T as an intervention to reduce IDH episodes[273] and more recently the European Best Practice Guidelines on cardiovascular instability accepted lowering T as an intervention to prevent IDH scoring the strength of evidential support as level I[274].

2.34 Cold to isothermic to cold again?

With the advent of BTM, the intriguing concept of lowering CT rather than keeping it constant through isothermic HD has risen recently. Van der Sande's group studied 14 patients with increased incidence of IDH over 3 mid week sessions. Thermoneutral, isothermic and CT cooling by 0.5°C were the interventions and BP changes, patient tolerance, changes in RBV and changes in cardiac output and central blood volume (CBV) were the parameters studied. Cooling the CT by 0.5°C resulted in better preservation of blood volume, a higher SBP and a substantially increased energy removal. IDH episodes were a mean of 3 each during thermoneutral and isothermic HD and one during CT cooling dialysis. Three patients however complained of shivering during CT lowering HD. Even though there is a tendency for better preservation of CBV and higher SBP, larger studies with longer monitoring are required to justify going beyond the isothermic HD remit[275].

2.35 Isothermic HD and HDF:

Extracorporeal cooling by the infused substitution fluid has been shown to be the significant factor conferring better tolerability of HDF versus HD. It still remains unclear as to whether pre- or post-dilutional HDF will be superior to isothermic HD. It is also feasible to apply the isothermic element to HDF and assess energy changes with and without the isothermic component. An Italian study currently recruiting will address this issue in a subset of patients prone to IDH over longer term[274].

2.36 IDH and CT rise in the absence of UF:

Gotch's volume hypothesis proposes a rise in CT dependant on UF volume and the degree of cutaneous vasoconstriction induced by this. However it is now clear that UF alone does not explain the heat accumulation during dialysis. In a study analysing the changes in CT during thermoneutral HD with and

without UF the rise in CT was identical, when isothermic HD with and without UF was carried out, energy removal required to keep CT constant did not differ significantly. Thus, other dialysis related factors, like purity of dialysate and the degree of backfiltration through the dialyser that is likely to increase metabolic rate; decreased cutaneous heat loss due to environmental factors, variations in the circadian rhythm of CT in uremia or removal of 'cooling' factors (?Adrenomedullin) during dialysis may all be implicated[276]. Further, larger studies are required to test these hypotheses.

2.37 Ultrafiltration profiling and sodium profiling:

Ultrafiltration profiling has been advocated as a means of reducing intradialytic hypotension.

The notion that isolated ultrafiltration causes less haemodynamic stress is well-established[277]. This led to the development of the concept of ultrafiltration profiling. A variety of profiles are available as alternatives to those employing a constant ultrafiltration rate. These include a linear decreasing profile, a stepwise decreasing profile, and various profiles in which intermittent pulses of high volume ultrafiltration alternate with ultrafiltration pauses. Very little work has been carried out to compare these profiles. The study by Donauer et al is probably the most useful. This study demonstrated a benefit of a linearly decreasing profile over a constant profile but also suggested that use of ultrafiltration profiles using intermittent high ultrafiltration pulses was associated with an increased incidence of intradialytic symptoms[261]. During the course of this study we have used high volume ultrafiltration pulses in some settings to investigate their effects on haemodynamic parameters but have not used them in routine clinical practice.

Most haemodialysis machines are also capable of sodium profiling. In this technique, instead of the sodium concentration in the dialysis fluid remaining constant, it is varied to produce a time-dependent profile over the course of a dialysis session. In standard profiles the initial sodium concentration is set higher than the time-averaged value. This level is reduced throughout the session to a level correspondingly less than the time averaged value towards the end of the session. The main aim of this, is to support the plasma osmolality in the initial stages of the dialysis, thus avoiding the osmotic disequilibrium consequent to the two-pool distribution of urea, thereby augmenting plasma refill and

avoiding transcellular fluid shifts. The lower dialysis fluid sodium levels in the latter stages of the session are meant to ensure diffusive loss of sodium at this stage so that there is no net gain of sodium throughout the session. The subject has been well-reviewed by Stiller et al[278]. There are serious problems with the evidence base for this technique. The 30 papers in this area generally describe brief studies using small heterogeneous groups. A wide variety of profiles were compared with standard dialysis utilising a constant dialysis fluid sodium. Many of these comparisons were inappropriate, and the majority of profiles (up to 60%), added sodium by diffusion (high time average dialysate sodium concentration). Only 23% were “isonatraemic”, and in only 17% of these studies, was there any account taken of the prevailing serum sodium concentration. Not surprisingly in these circumstances, many of the studies were associated with a reduction in intradialytic hypotensive episodes, and less symptoms of disequilibrium. In many cases though, these advantages were achieved at the expense of sodium overloading, manifesting predominantly as interdialytic hypertension. It is fair to say that, though sodium profiling is has a reasonably high clinical profile, that the evidence of long-term benefit is scanty, and that the potential for problems, is not insignificant. There have also been a number of studies of combined ultrafiltration and sodium profiling. These small, short-term studies suggest that the combination of a linearly decreasing ultrafiltration profile with a sodium balance neutral, linearly decreasing sodium profile, may have some haemodynamic advantage [279;280]. Sodium profiling has not been used as a tool in used in the subsequent clinical studies which form part of this thesis.

Chapter 3

Bioimpedance

3.1 Introduction

Renal replacement therapy (RRT) in the form of haemo- or peritoneal dialysis aims to achieve a reduction in the concentration of toxic molecules accumulating as a result of loss of kidney function, whilst also aiming to normalise the total body water content by ultrafiltration (UF). The quality of solute removal is assessed by urea kinetic modelling and appropriate adjustments are made to the duration of a HD session or to the volume of fluid exchanged in the case of PD, to maintain a target Kt/V . However there are no adequacy standards for volume removal. Clinical assessment of volume status has major limitations and there is a high prevalence of occult and often overt hypervolemia, significant inter-dialytic hypertension, inappropriate use of hypotensive agents and accelerated cardiac morbidity and mortality. Alternative techniques have been evolved to assess and manage the UF requirements, ranging from BP profiling, relative blood volume monitoring, doppler ultrasound (US) measurements of inferior vena caval (IVC) diameter, pre- and post dialysis, echocardiography, natriuretic peptide concentrations, and bioimpedance. This chapter concentrates on the evolution of the bioimpedance technologies over the last three decades and their increasing use in the dialysis population to assist volume assessment.

3.2 Early History of bioimpedance

Bioimpedance refers to the resistance offered by tissues to the passage of an electrical current. It is determined by the ionic conductance of tissue fluid offset by the dielectric properties of tissue interfaces. By the early and mid twentieth century the conducting characteristics of mammalian tissues to the passage of alternating current at varying frequencies had been defined. Early research explored tissue conduction responses to electric current of single, dual or multiple frequencies. Multiple frequency analysis defined the dispersion characteristics of tissue interfaces. Work by Cole[281] led to the evolution of a multi-frequency impedance model that has now been incorporated (with modifications) into many modern bio-impedance analysers. Thomasset[282] investigated the single frequency model, defining the relationship between total body water and measured resistance to the applied electric current. Nyboer had earlier reported on the usefulness of the bioimpedance technique in the evaluation of circulating blood volume, a development which led to the evolution of bioimpedance plethysmography for cardiac output

measurements[283;284]. The relationship between resistance and body water was further strengthened by the report of Hoffer *et al* in 1969[285] on their equations for the calculation of total body water (TBW) based on tetra-polar bioimpedance measurements made at chosen alternating current frequencies between 100 Hz to 1MHz. The subjects were 20 healthy medical students and 34 patients, 15 of whom had advanced renal failure. Hoffer's observations led to the development of a number of prediction equations based on the impedance index (Ht^2/Z). As discussed subsequently, the impedance index forms the cornerstone of bioimpedance technologies as applied to body composition analysis. This is the physiological equivalent of the mathematical construct and assumes the human body to be a cylinder with the height taken to be the length and its volume inversely proportional to its electrical resistance. The validity and accuracy of such models have been questioned and their limited usefulness in the setting of altered hydration states spurred on the development of the multi-frequency method and the field of impedance vector analysis.

3.3 Basic principles

The explanations for terms used in the description of the technique are summarised in Table 3.1

Table 3.1: Explanation of terms and principles used in Bioimpedance

Definitions	
Alternating current (AC)	<p>in AC current the voltage oscillates in a sine waveform given by the equation</p> <p>Instantaneous voltage $V = V_0 \sin \omega t$ (1)</p> <p>Where ω is the angular frequency related to the frequency 'f' as</p> <p>$\omega = 2\pi f$ (2)</p>
Resistance (R)	<p>Opposition to flow of an electric current through an object</p> <p>Measured in Ohms (Ω)</p> <p>Calculated as</p> <p>$R = \rho L / \Lambda$ (3)</p> <p>Where ρ is the specific resistivity of the material, L its length and Λ its cross sectional area</p> <p>Also calculated through Ohm's law as</p> <p>$R = V / I$ (4)</p> <p>where V is the potential difference in volts across the object and I the current that passes through it in amperes</p> <p>Resistance in an AC circuit is given by</p> <p>$R = (V_0 \sin \omega t) / (I_0 \sin \omega t)$ (5)</p> <p>In an AC circuit with only resistors the current and voltage are in phase with each other</p>
Resistivity (ρ)	<p>Measure of the material's ability to oppose flow of current through it</p> <p>From (1) above</p> <p>$\rho = RA / L$ (Ωm) (6)</p> <p>Defined differently, it is the reciprocal of conductivity (σ)</p>

	$\rho = 1/\sigma$ (7)
Capacitor	A device capable of storing electrical energy Constructed as two plates with conductance σ , area A , separated by a distance 'd' with a non-conducting material in between called the dielectric with a permittivity ϵ
Capacitance (C)	The factor determining the amount of charge 'Q' that could be stored for a voltage 'V' Capacitance is directly proportional to the area of the conducting plates and inversely proportional to the distance 'd' separating them $C = \epsilon A/d$ (9) Where ϵ is the permittivity constant of the dielectric material C can also be expressed as $C = Q/V$ (10) where Q is the charge stored with V being the voltage across the conducting plates (Coulomb per volt or Farad)
Reactance (X)	The resistance offered to the flow of current in an AC circuit by a capacitor and/or an inductor $X_c = 1/2\pi fC$ (8) Where X_c is the capacitive reactance, f is the frequency of AC current and C the capacitance $X_L = 2\pi fL$ (9) Where X_L is the inductive reactance of an Inductor with inductance of 'L' Henries
Impedance (Z)	The total opposition to flow of current in an AC circuit. This is determined by the circuit elements: resistor, capacitor and inductor In the bioimpedance field, this is simplified as that arising from a capacitor and resistor connected in series or parallel. Impedance is a complex number with a real and an imaginary part represented in a polar form as $Z = Z e^{j\theta}$ (10) Where e is the exponential notation, j an imaginary number defined as $j^2 = -1$ and θ the phase angle The numerical value of Z can be calculated as $Z = (R^2 + X_c^2)^{0.5}$ (11) And $Z = X_c * R / (X_c + R)$ (parallel) (12) The calculation of phase angle requires representation of Z in a vector form and calculation of Φ as the angle opposite the right angle in a right-angled triangle (Pythagorous Theorem)
Permittivity	Defined as a material's ability to transmit an electric field, also called the dielectric constant Higher the permittivity higher the capacitance and more will be the energy stored for a given AC voltage The permittivity of body tissues changes with the frequency of the applied current
Beta dispersion[286]	The change in the capacitance characteristics of the human skeletal muscle in the AC frequency range 1kHz to 1MHz Thought to be due to the phospholipid bilayer Vital in bioimpedance spectroscopy to differentiate conductance through ECW and TBW compartments
Anisotropy[287]	Variation in the electrical field generated when the applied current is parallel or perpendicular to the orientation of tissue fibres. The Wrist-Ankle bioimpedance model assumes minimal anisotropy with electrode placements in wrist and ankle with frequencies of applied current in the β dispersion range
Characteristic frequency	AC frequency at which capacitive reactance is maximum for the tissue studied, is a function of the integrity of the cell membrane
Phase angle	$\tan^{-1} \Phi = X/R$ Where X and R are reactance and Resistance respectively Defines the 'out of sync' characteristic of voltage and current in an AC circuit with a Resistance R and reactance X

3.3.1 Resistance-volume relationship

The conductance of human tissues is directly proportional to the volume of the ionic content that is accessible to the passage of electric current. The resistance to electrical conduction occurs at non-conducting interfaces and tissues (*eg* bone and pulmonary tissue). The combination gives a complex heterogenous unit whose conducting properties are difficult to define accurately and become even more tenuous in abnormal hydration states. Nevertheless, in the initial half of the 20th century, with the development of accurate sine wave generators, attempts were made to develop a workable model.

In its simplest form the resistance offered by a conductor of length ‘L’ and cross-sectional area ‘A’ is given by

$$R = \frac{\rho L}{A} \quad (1)$$

Where R is the resistance in ohms (Ω), ρ the resistivity in ohm centimetres ($\Omega \cdot \text{cm}$)

Multiplying both the denominator and numerator by L, the equation becomes

$$R = \frac{\rho L^2}{AL} \quad (2)$$

The quantity AL is the volume of the cylinder and substitution and rearrangement gives the volume equation

$$V = \rho L^2 / R \quad (3)$$

This equation forms the cornerstone of impedance-volume calculations and has been modified to fit either total body water (TBW) or extracellular water (ECF) in a reference population when isotope dilution derived volume data is available for regression analysis. ‘L’ is the length of the conductor that

usually is taken to be the height (Ht) of the subject. The 'R' component is the total resistance and is often referred to as impedance (Z). Volume of a cylinder therefore is inversely proportional to its impedance.

3.3.2 Alternating Current (AC)

Alternating current differs fundamentally from direct current (DC) as the direction of current flow changes cyclically with time. This rate of change is the frequency of AC. This is 50Hz in most domestic and industrial electric supplies with the exception of United States where it is 60Hz. Sine wave generators can provide an AC circuit of current strength 'I' and voltage 'V' where the current frequency can vary between the kilo Hertz (KHz, 1Khz = 1000Hz) to Mega Hertz (MHz, 1 MHz = 1000KHz) range. This frequency range induces a stepwise recruitment of conduction through different body compartments that enables the investigator to calculate different compartment volumes.

3.3.3 Frequency dependent conduction:

The ability of mammalian tissues to maintain an electrical field in response to an applied current (the permittivity of the tissue) changes with the frequency of the applied current. This is thought to be due to the property of the phospholipids bilayer of cell membranes to behave as a capacitor with capacitance in the nano-Farad (nF) range.

The capacitive reactance (X_c) is related to the current frequency as

$$X_c = 1/2\pi f^2C \quad (4)$$

Where 'C' is the capacitance and 'f' the frequency of the alternating current applied.

From Equation 4, it is clear that at higher frequencies the capacitive reactance decreases, making the cell membrane more 'conductive'. This dramatically increases the conducting volume of the tissue with the recruitment of the intracellular water (ICF) compartment. Recognition of this led to the development of a dual/multi frequency current model that could potentially differentiate ECF and TBW compartments based on the resistance characteristics to the frequency of the applied current. At low frequencies, the ECF compartment is the conducting pathway, whereas at highest frequencies, the loss of cell membrane

capacitance causes conduction through both ECF and ICF compartments allowing calculation of TBW. This, however, introduces complexity to the volume-impedance model because of the uncertainty in defining the appropriate low and high frequency AC signals that exclusively will conduct through ECF or TBW respectively. It is also difficult to develop voltage generators with such high resolutions when the magnitude of the applied current is in the 0.8 – 1.2 mA range. Nevertheless a frequency of 5kHz for ECF and 50 or 100kHz for TBW have been widely used and the resultant volume equation takes the form of

$$V = a*(Ht)^2/R_5 + c \text{ for ECF and} \quad (5)$$

$$V = d*(Ht)^2/R_{50} + e \text{ for TBW} \quad (6)$$

Where ‘a’, ‘b’, ‘c’ and ‘d’ are constants derived by regressing TBW/ECF volumes derived by reference method against the impedance-index[285].

3.3.4 The current circuit

Traditional bioimpedance measurements are made in the tetra-polar configuration. A pair of current (I) electrodes are placed on the dorsum of the hand at the base of the fingers and on the forefoot whilst another pair of voltage (V) electrodes are placed proximal to ‘I’ leads at the wrist and ankle respectively. The upper limb (UL) and lowerlimb (LL) leads are usually ipsilateral though Hoffer and other investigators had adopted a contralateral placement to maximise conductor length. The current amplitude is 0.8 – 1.2 mA and not discernable by the subjects.

The conducting elements analogous to a circuit diagram will be the ECF resistance (R_{ECF}), ICF resistance (R_{ICF}) and cell membrane capacitance, C_m , giving rise to capacitive reactance (X_C). It is obvious that R_{ICF} , R_{ECF} and X_C could be arranged in a serial or parallel configuration with different resultant total impedance (Z) values. The parallel model is preferred as a more physiological representation of the ECF and ICF and was first proposed by Cole in early 1930s [288]. (Figure 3.1)

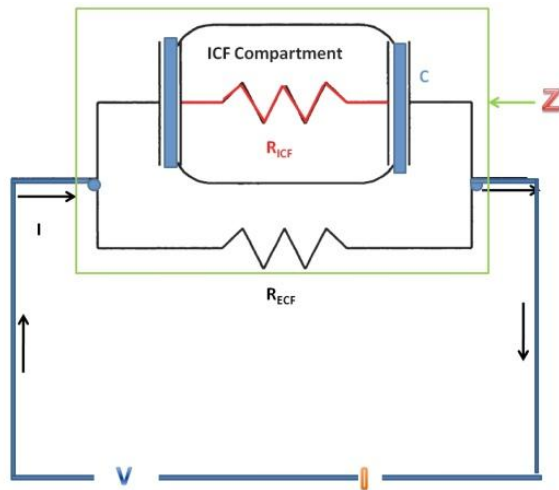

Figure 3.1

Equivalent electrical circuit:

ECF and ICF compartment separated by cell membrane of capacitance 'C' arranged in parallel configuration. 'V' and 'I' are voltage and current respectively, 'Z' the impedance. Total impedance given by the sum of impedance of ICF compartment and resistance of ECF (R_{ECF})

(parallel law of summation of Resistances)

Instruments using the series model (involving conversion of serial impedance measurement to its parallel equivalent) have been in use since the early 1980s and are usually used with equations derived for a reference population by regressing volume data against isotope dilution derived data[289;290].

3.3.5 Impedance and phase angle

The measured impedance is the sum of the capacitive reactance (cell membrane and other tissue interfaces) and resistance (ECF and ICF) whatever the configuration employed (series/parallel, single/dual/multi-frequency). The capacitive reactance causes the applied current to lead the measured voltage by the phase angle. Therefore impedance is expressed in a vectorial form incorporating the absolute value and the phase angle. Whilst the importance of phase angle in an electrical circuit is academic, it assumes huge importance in tissue impedance analysis. Phase angle is a direct measure of capacitance and hence is crucial for developing a biophysical model that can accurately delineate the ECF and ICF. The complex impedance is measured based on the drop in voltage across the biological circuit (wrist-ankle configuration) for a given amplitude of alternating current (0.8-1 mA). Further resolution of the absolute value of the impedance will yield ECF and TBW resistance in ohms that can then be regressed for respective compartment volumes. This method is used for a single/dual frequency bioimpedance model. For multifrequency bioimpedance analysis, where the complex impedance is measured at different frequencies sequentially, the ECF and ICF resistances are derived based on the response to a group of low and very high current frequencies.

3.4 Body composition in bioimpedance volume modeling

The field of body composition analysis continues to evolve at a rapid pace with more sophisticated techniques now available to measure various components of a composite model. In its simplest form, the human body can be envisaged to be made up of fat tissue and the fat free mass (FFM), sometimes referred to as the 2 compartment (2C) model. A further subdivision, splitting the FFM into its liquid and solid compartments (3C) allows for the development of techniques to measure ICF (total body K⁴⁰ analysis), ECF (bromide dilution) and TBW (deuterium dilution, tritiated water, ¹⁸O₂ dilution) and bone mass by DEXA. Bioimpedance methodology applies this modified 3C model to the human body indirectly relating the measured electrical parameter to the volumes. For the sake of simplicity, the human body is divided into 5 cylinders (2UL, 2LL, trunk) and the height of the subject being the length of the current pathway[291-296].

3.4.1 Single and multi-frequency bioimpedance analysis (SF-BIA and MF-BIA):

Thomasset had used a single frequency bioimpedance analyser to describe the relationship between the total resistance of the biological system and the water content. The choice of 100kHz was arbitrary and reflected the available resolution of the sine wave generators of that time[282]. Hoffer had experimented with other AC frequencies and concluded that a frequency of 50kHz or 100kHz would both be appropriate to explore the resistant-volume relationship[285]. Nyboer had earlier modelled the current circuit to be in parallel configuration [284], ECF compartment in parallel arrangement with cell membrane capacitance and ICF, this coupled with the easy availability of analysers using the 50/100kHz current, led to the widespread acceptance single frequency parallel configuration bioimpedance analysers. A dual frequency model was proposed by Deurenberg and Schouten[297] to differentiate conduction by the ECF and TBW using 5kHz and 50kHz respectively. The model used the parallel circuit configuration and was used widely in the field of nutrition to define indirectly the ICF and BCM[292;298;299]. Other investigators have used multiple frequencies on a logarithmic scale to measure TBW and ECF by developing equations regressed from volume parameters derived from isotope dilution methods. (MF-BIA)[300;301]

3.4.1.1 Single frequency method (SF-BIA) and the R-X_c graph (or BVA):

The impedance at 50 KHz can be resolved into its respective reactance and resistance components in either series or parallel configurations. The impedance measured is represented in vector form with a magnitude and phase angle (PA, Φ). If the magnitude and PA are known, it is possible to resolve the vector into its resistance and reactance components applying trigonometric principles. This is represented graphically with the reactance represented by the Y-axis and resistance in the X-axis. It is possible to derive the respective values for a parallel configuration (ECF and ICF compartments connected in parallel) from its series equivalent. The most widely used single frequency analyser marketed by RJL Systems in 1984 (Detroit, Michigan, USA) deployed this algorithm to calculate TBW from predictive equations .

Piccoli *et al* [302;303] used the graphical representation of the impedance vector and its resistance and reactance components to plot data from a large cohort of healthy subjects, describing a plane of high probability in which most of the impedance vectors would lie. (Figure 3.1) Comparisons were then made with impedance vectors from patients with abnormal hydration or obesity. The resistance and reactance values were normalised to the height of the subjects. This representative method was called the R-X_c graph or bioimpedance vector analysis (BVA).

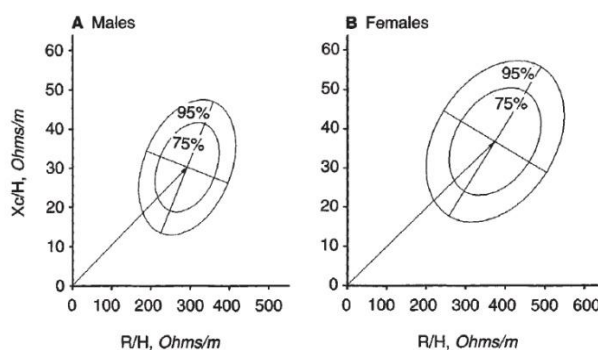

Figure 3.2: R-X_c point graph
 Derived from a reference healthy population, ellipses representing 75% and 95% confidence intervals
 A: Males B: Females R: Resistance X_c: Reactance
 H: Height
 The vector represents impedance of an average healthy subject
 (reproduced with permission from Piccoli *et al* *Kidney International*, Vol. 46 (1994), pp. 534—539)

3.4.1.2 Bioimpedance Spectroscopy: (BIS)

Multifrequency impedance had been used extensively by various investigators in the early twentieth century to define the electrical properties of animal tissues. Work by Geddes, Schwann, Frick and others had increased understanding of electrical conduction in mammalian tissues and defined the dispersion characteristics of the skeletal muscle that underpins multifrequency bioimpedance modelling even today[286;304-307]. However it was not until the work of Cole, defining the dielectric properties of tissues, that multifrequency bioimpedance was recognised as a potential tool for volume modelling. Cole had described impedance and phase angles obtained at different current frequencies in the form of an impedance locus[308][309-311] (Figure 3.3)

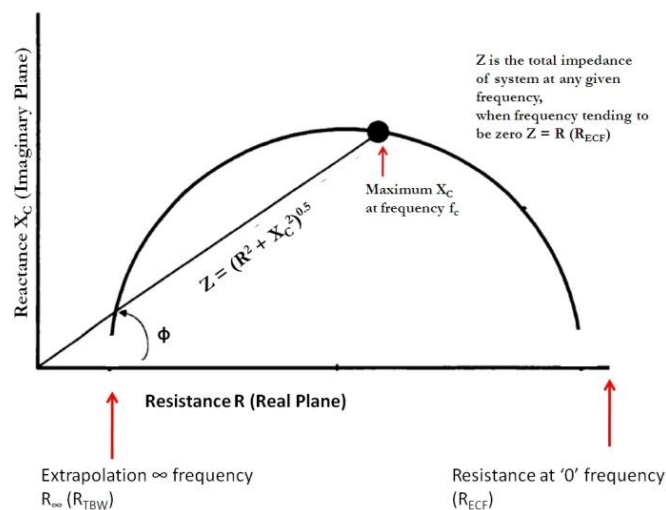

Figure 3.3: Impedance locus:

Reactance in imaginary plane while Resistance in real plane, increasing current frequency from right to left, individual impedance values at each frequency cluster to form the locus. Assumes a semicircle with a depressed centre. Extrapolation onto real axis will give respective TBW and ECF resistances (infinite and 0 frequencies respectively)

The frequency at which Impedance (Z) is maximum is the characteristic frequency of the model (f_c)

Φ is the phase angle, R_∞ resistance at extrapolated infinite frequency, X_C is reactance, R is total

The locus takes the form of a semicircle with a depressed centre lying below the X-axis, with its constituent coordinates defined as a pair of resistance-reactance values at different frequencies mapped on a Cartesian plane incorporating the imaginary number scale. The imaginary part of the scale describes

the capacitive reactance. Using this representation it is possible to derive a hypothetical value for impedance at zero and infinite frequencies that will represent ECF and TBW resistance respectively. The advantage of this approach was that the model lent itself to the derivation of ICF resistance and thereby estimation of ICF volume. The frequency of current at which the capacitive reactance was maximal was defined as the characteristic frequency of the biological tissue. Extrapolation allowed for more accurate TBW and ECF estimations. This was defined as bioimpedance spectroscopy (BIS) and was adopted across various disciplines. Whole body bioimpedance analysers using the BIS principle became widely available (WBIS) and later segmental BIS (SBIS) instruments were used in nutrition and dialysis fields due to potential for greater inaccuracies with the WBIS method.

3.4.2 Mixture theory:

The human body is heterogenous with conducting and non-conducting media arranged randomly with innumerable interfaces between. The assumption that introduced current will travel exclusively along pre-determined pathways through conducting elements, is erroneous. Therefore the entity 'apparent conductivity' was explored by the proponents of the multifrequency model. This required adoption of the emulsion theory proposed by Tetsui Hanai in 1963 [312] to the body composition model. Mixture theory corrects for presence of the non-conducting elements and aims to improve the accuracy of the volume calculations[296].

3.5 Bioimpedance in the dialysis population:

Probing for dry weight in the dialysis patient is usually achieved by progressive ultrafiltration (UF) over successive sessions until clinical euvolemia is achieved. This however is hampered by various factors including short UF sessions, use of antihypertensive agents and the presence of significant cardiac disease. All these factors promote intra-dialytic haemodynamic instability in many patients as dry weight is approached. Bioimpedance has been used as an adjunct to clinical assessment by providing estimates of ECF and TBW compartment volumes pre- and post-dialysis.

The applicability of the bioimpedance technique in terms of reactance and phase angle changes was reported in 1974 by Nyboer whilst measuring impedance at 50kHz pre- and post-dialysis. Nyboer reported a lower phase angle and reactance at 50 kHz pre dialysis that returned to that seen in healthy individuals post-dialysis[284]. This was interpreted as due to changes in fluid distribution. Kanai and his co-workers(1983), reported a multifrequency approach (1kHz to 100kHz) to study the resistance characteristics of the lower leg volume compartment in healthy volunteers before and after exercise and in a single dialysis patient before and after a dialysis session.[313] They had used the Cole model, though without extrapolation, calculating the resistance at the lowest and the highest test frequency range. The extracellular fluid resistance (R_e) increased after a dialysis session and also in athletes after a period of intense exercise. Intracellular fluid resistance did not change in the authors' experiments. Further note was made of a characteristic β dispersion frequency of 50 kHz. It could be argued that, frequencies used were not wide enough and perhaps therefore did not truly reflect total body water resistance, possibly leading to an erroneous conclusion of a characteristic frequency of 50 kHz. Nevertheless, this research established a way forward for the multi-frequency method and led to the future development of the extrapolation algorithms for ECF and TBW resistance.

A conductivity based approach was tested by De Vries in 6 dialysis patients using a frequency range of 3-200 kHz. Aluminium, circular, tetra-polar electrodes were placed on the arm, two outer current electrodes and an inner pair for voltage measurement. A current of 1mA was generated from a sine-wave generator. Conductivity changes were measured during 3 dialysis sessions per patient with different UF strategies employed for each session [uniform UF, and an hour of isolated UF at start and end of a 5 hour otherwise isovolemic dialysis]. Readings were obtained at hourly intervals (n = 120). The authors described an algorithm derived from their previous work with solutions made up of plasma and red cells of varying dilutions and the Hanai mixture theory to predict intra-cellular and extra-cellular conductivities. These parameters were frequency dependant with low frequency conduction exclusively extracellular and high frequency representing conductivity of the whole system. An exponent of 1.5 was applied to the extracellular conductivity to estimate extracellular volume. Conductivities of the ECF compartment decreased throughout dialysis with UF and the pattern varied with different UF strategies. The drop in

ICF conductivity was significantly less than that of the ECF component. The authors concluded by noting the potential of the technology to describe fluid shifts during dialysis by measuring the ECF/ICF conductivity ratio employing a multifrequency approach. The authors, however, did not elaborate on the usefulness of the mid frequency ranges and did not use the Cole-Cole model of impedance (see below)[299;314-316] .

A single frequency approach was later described by Scanferla and colleagues in 23 haemodialysis patients who had their resistance and reactance measured at 50kHz continuously through a dialysis session. It was observed that the resistance was strictly inversely correlated with body weight ($r = 0.82$) and reactance increased almost continuously through dialysis. The change in reactance was disproportionate to that of the resistance and consequently was associated with an increase in phase angle. In seven patients with symptomatic hypotensive episodes, reactance decreased sharply during the event whilst the resistance continued to rise. The authors implied that this change in reactance may be an useful indicator of impending hypotension and that the technique could be useful to track fluid changes and would be reflective of the intactness of the cell membrane. This is the earliest reported use of the bioimpedance technique, continuously, in the dialysis population[317]. A comparison of the single frequency and multiple frequency analysers was performed by Jaffrin and his colleagues in 10 patients on regular haemodialysis. The authors had tested the validity of the Cole-Cole model against the $R-X_c$ approach and noted that the method of extrapolation of the impedance data to zero and infinite frequencies may have yielded a more accurate representation of the ECF and ICF resistances and consequently better volume derivations assuming resistivities of the ECF and ICF compartments remained constant during dialysis. The authors had measured the conductivities of the plasma in a single patient every 30 minutes as dialysis progressed and observed a 6% variation that did not translate to a significant change in resistivity between the pre- and post-dialysis sample[318-320].

Sinning *et al*, in 1993, adopted a single frequency approach to measure TBW in their dialysis cohort ($n = 22$) and compared the results with deuterium dilution and anthropometric equations. They had derived an equation incorporating the impedance index and weight by regressing the dilution derived TBW with the

bioimpedance derived parameter. A total of 8 equations were tried and a best fit equation was proposed[321].

3.5.1 Whole Body Multifrequency Analysis (WBIS) in dialysis

A multifrequency approach was used by Ho and his co-workers[322] in 1994 to study a wrist-ankle bioimpedance technique for its accuracy in volume prediction. Eight dialysis patients had their TBW measured by the D₂O dilution method pre- and 2 hours post-dialysis. Dilution measured TBW in the matched healthy controls was used to derive a regressed equation for TBW using the impedance index at 148kHz. The equation provided by the manufacturer of the device (Xitron Tech, San Diego, CA, USA) developed from the Cole-Cole and Hanai model was also used to measure TBW in both groups mentioned above and also in a third non-control group comprising of healthy volunteers. The regressed equation was then used to calculate the TBW in the dialysis patients pre- and post-dialysis, compared with the dilution derived TBW pre- and post-dialysis and then finally with the TBW derived using the manufacturer's equation. The mean TBW values from the two methods were not statistically different to the dilution derived TBW values but did show a variation around the zero line when the differences between these methods was plotted with the dilution derived value taken as the abscissa. The mean absolute difference was 2.3L for the regressed equation and 1.8L for the manufacturer provided equation giving a mean error of measurement of $5.9 \pm 3.2\%$ and $4.4 \pm 3.9\%$ respectively. This was one of the earliest studies comparing the accuracy of the volumes derived by both a regressed equation and the Cole model against the gold standard dilution technique in dialysis patients pre- and post-dialysis. It is to be pointed out that, even though, there were no statistically significant differences between methods. The differences in volumes measured in individual patients was still large enough to introduce some doubt about the accuracy of either of these methods when trying to ascertain the achievement of euvolemia in prevalent or incident dialysis patients. It is also important to note that the regressed equations are a product of statistical manipulation rather than those derived via a scientific volume model incorporating the impedance characteristics. Lastly the authors explored a whole body approach with a proximal placement of the leads that is seldom used in current practice. However, in spite of these shortcomings, the authors had shown the possibility of using a multifrequency bioimpedance approach (incorporating corrections

for the non-conducting components) to non-invasively measure total body water and also the ECF volume.

3.5.2 R-X_c Graph (BVA)

In the same year, Piccolli and his colleagues proposed a novel method for assessing the hydration status of a patient by measuring the impedance vector lengths and phase angles in a single frequency model. (previously referred to, Figure 3.2) The impedance data at 50kHz was collected in 86 healthy subjects, 55 patients with CRF of varying stages with and without oedema, 36 patients with nephrotic syndrome and 40 obese subjects. The components of the complex impedance, namely, resistance (R) and reactance (X_c) were normalised to the height of the subjects and plotted against each other. The authors showed that there was an ‘elliptical area’ of normality based on the data from healthy subjects could be used as a guide when plotting data from subjects with altered hydration states. The impedance vector was predicted to fall within this ‘ellipse’ with a 95% probability in healthy individuals and an individual subject’s impedance vector could be predicted to fall within the ellipse with a 75-95% tolerance limit. This was called the “RX_c point graph”. To achieve normovolemia, one would, therefore, not need actual volume data of TBW or ICF compartments, but just to track the position of the impedance vector from the start of an intervention (UF or rehydration) aiming to progress the vector to the ‘ellipse of normality’ on the post-intervention R-X_c plot. (Figure 3.4) Adjusting for age and sex will allow for further refinement of the ‘normal’ plot improving accuracy. By a rule of thumb, a short impedance vector is indicative of over-hydration or obesity. The authors alluded to the simplicity of this approach as long as data from a large reference population is available and is stratified into age, sex and body mass index sub-groups[302]. It is feasible that ethnicity may also need to be considered.

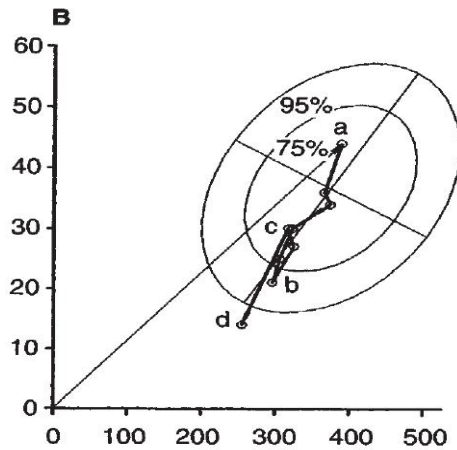

Figure 3.4: Vector migration with hydration state

Change in length of impedance vector in a female subject with progressive renal failure, vector at point 'c' when fluid overloaded, migrated to position 'b' as diuretics caused volume reduction, drift to position 'd' with further reductions in renal function requiring dialysis and migration to position 'a' (dry)

(reproduced with permission from Piccoli *et al* *Kidney International*, Vol 46 (1994), pp. 534—539)

The widespread use of the bioimpedance (single and multifrequency) technique in the field of nutrition, obesity research, exercise medicine and disease states and the availability of multiple equations to measure TBW and fat free mass led up to a consensus statement in 1994, appraising the technology and detailing its caveats. A summary of available knowledge emphasised the unreliability of the technique in disease states, its susceptibility to various interferences and the surfeit of unreliable population specific equations derived by statistical association rather than scientific reasoning. A robust scientific approach was sought to explain the measured impedance and its relationship with volume[323].

The scientific approach became possible with the increasing advance of technology and the availability of highly accurate sine wave generators. The Cole-Cole model and Hanai mixture theory gained wide acceptance in the multifrequency arena for the measurement of component volumes. One of the popular algorithms was developed by Matthie *et al* and De Lorenzo *et al* in 1992 and later modified in 2005 [300;324-327]. This is discussed in some detail below. This model has been widely adopted by various investigators in the nutrition and body composition field and has enjoyed a greater penetrance in the dialysis community grappling with the dry weight conundrum.

The authors start off by describing a circuit model with ECF and ICF resistance and reactance compartments in parallel configuration. This leads to innumerable intracellular current paths consequent to the heterogeneity of the tissue interfaces. The frequency dependant, cell membrane capacitance driven electrical path isolation introduces a previously undescribed complexity to the impedance calculation by way of the invariant time delay (T_d). T_d occurs due to the delay in conduction arising as a consequence of

complex circuit paths before the voltage is measured at a downstream electrode. In addition, T_d also occurs as a consequence of contact resistance, stray interference and the position of the subject in relation to the ground. T_d affects phase angle measurements in the impedance vector and should be corrected for to accurately fit the composite Z (real and imaginary part) to a mathematical model. The authors compared ICF data obtained in 87 healthy subjects using total body potassium measurements (TBK⁴⁰) and TBW and ECF values obtained in 14/87 men who underwent deuterium and sodium bromide dilution studies with volume parameters derived via multifrequency bioimpedance measurements. Twenty one frequencies ranging from 1 KHz to 1.248MHz were used and the complex impedance value obtained at each of these frequencies was fitted to the impedance locus as described by Cole. Extrapolation to zero and infinite frequencies allowed for the derivation of ECF resistance and TBW resistance. Using multiple frequencies allowed for the probing of cell membrane capacitance. This increased with an increase in current frequency with a resultant increase in total impedance until a frequency f_c , called the characteristic frequency is reached. Comparison with impedance values obtained at low (predominantly due to ECF water, therefore ECF resistance, R_{ECF}) and high frequencies (TBW resistance) allowed for the derivation of ICF resistance (R_{ICF}) using the parallel law of summation of resistance/reactance.

This first step was followed by the development of volume equations incorporating these resistance values, borrowing heavily from Hanai's mixture theory of emulsion conductivities. Briefly, the observed conductivity, ρ of a system composed of a non-conducting fraction of volume C , is given by

$$\rho = \frac{\rho_0}{(1 - C)^{\frac{3}{2}}} \quad (7)$$

where ρ_0 is the true conductivity of the emulsion. 'C' in human body consisted of predominantly the bony skeleton and air-tissue interfaces (lung, gut). The exponent, $\frac{3}{2}$, in the above equation was true for emulsions with small non-conducting spheres and a similar analogy was proven earlier for human blood. The authors hypothesised that the Cole model derived resistance could be scientifically proven to be a function of compartment volumes rather than the statistical association reported by various authors in the

past by regressing dilution derived volume data to the impedance parameter. Thus the authors modified the ‘impedance index’ to

$$V = k_{ECW} \times \left(\frac{L^2 \sqrt{W}}{R_{ECW}} \right)^{\frac{2}{3}} \quad (8)$$

Where ‘W’ is the weight of the subject and ‘L’ the height of the individual

The incorporation of W raised to the exponent 0.5 allowed for an indirect interpretation of conductivity as envisaged in the mixture theory influencing the volume calculations. Raising the revised impedance index to the factor, $\frac{2}{3}$, was substantiated by the authors as an accurate assumption based on the mixture theory and the dependence of volume on weight and density. The constant k_{ECW} was defined as

$$k_{ECW} = \frac{1}{1000} \times \left(\frac{K_B^2 \times \rho_{ECW}^2}{D_b} \right)^{\frac{1}{3}} \quad (9)$$

Where K_B is an anthropometric constant relating to the proportion of arms, legs and trunk; ρ_{ECF} is the ECF resistivity; D_b is the density of the human body. If the resistivity values of the ECF and ICF compartment were known (based on dilution studies), the volume calculations were simplified by the investigators as

$$\left(1 + \frac{V_{ICW}}{V_{ECW}} \right)^{\frac{5}{2}} = \left(\frac{R_{ECF} + R_{ICF}}{R_{ICF}} \right) \times \left(1 + \frac{k_\rho V_{ICW}}{V_{ECW}} \right) \quad (10)$$

where k_ρ was defined as a ratio of intra-cellular to extra-cellular resistivities.

The authors had computed the ECF and ICF resistivity based on dilution data from 14 subjects. They had also alluded to the caveat that, the accuracy of the volume model depended significantly on computed resistivity of ECF and ICF compartments from isotope dilution methods. The authors stated that the ICF obtained from dilution methods ($D_2O - NaBr$ volume) correlated less strongly with TBK⁴⁰ derived ICF, implying the difficulties in calculation of ICF even if R_{ICF} was calculated reasonably accurately from the Cole model. Furthermore the accuracy of Hanai’s mixture theory is somewhat dubious when corrections

are made on the original assumption of small non-conducting spheres. The human body is far too complex an entity to derive equations to correct for the non-conducting volumes based on an exponent of 1.5. Nevertheless, the recognition that such a correction needs to be made, and the non-availability of an alternate rigorously tested conductivity model, led the authors to adopt this version of the mixture theory. Though the numbers do not appear large enough to test validity across populations and disease states, the work underlines the potential of the bioimpedance technique in the accurate estimation of compartment volumes. The authors had set out to develop a scientific model that explained the measured impedance in relation to the conducting volume and to a large extent had succeeded. This moved the bioimpedance argument forward as a scientific tool rather than a technique whose veracity depended on statistical correlation between measured impedance and dilution derived volumes.

3.5.3 Segmental Bioimpedance Analysis (SBIS):

The wrist-ankle (WA) electrode placement as described by Thomasset in 1962 and later by Hoffer in 1969, assumed the geometry of the human body to be a cylinder with a conduction path from the extremities of the upper limb to the ipsilateral or contralateral lower limb. The resistance depended on the conductor length, usually taken to be the height of the subject, the resistivity of the material and the circumferential area. The volume of the conductor was proportional to the resistive index (Ht^2/R) as described elsewhere and all volume equations derived either by stepwise regression analysis or through the Cole-Cole model of extrapolation reflect this. The total resistance measured by a single frequency WA method is predominantly weighted towards the contributions from the arms and legs (smaller area, larger proportional length) with little measurable output from the trunk. Such approximations have been proven to be erroneous in studies with a large number of normal subjects (Segal *et al*, 1567 subjects) where it was shown by the authors that the fat free mass (FFM) related better to Ht , R and weight of the individual rather than the resistance ratio[328]. A segmental approach was hypothesised to be more accurate if the contributions from the limbs and trunk could be measured separately and added together as resistances in series. Organ *et al* [329] reported such an approach in 1994, using a single frequency analyser at 50kHz, in 200 healthy (96 men) subjects. D_2O dilution, anthropometry and underwater weighing (UWW) was used to measure TBW and thereby FFM; body density and fat content; and relative lengths, circumferential

area and volume of individual segments respectively. The electrode placement for segmental measurements were at the wrist, ankle, shoulder, hip and sternum with 25 readings obtained from placements in ipsilateral and contralateral configurations. The authors reported that the total resistance obtained through the standard wrist-ankle technique was not significantly different to the sum of the segmental resistances obtained by measuring resistance parameters of the UL, LL and the trunk. The authors attempted a resistivity based approach to correlate FFM obtained by densitometry with sum of the segment specific resistivities. The resistivity was calculated using the anthropometric measurements of the limb diameters and circumferential area. Such an attempt yielded a correlation coefficient of 0.75 with a SEE of 5.17 kg. Addition of weight, age, average cross sectional area of trunk and limbs and height yielded better correlations and lower SEE. (0.9 and 2.92L respectively).

The authors did highlight the difficulty of this model in as much as the number of measurements one needs to do before calculating the FFM through a regressed equation. However this study highlighted the important flaw in the conductivity model of bioimpedance that did not take into account either the heterogeneity of the human body or the consequent variations in resistivity characteristics. The fact that the trunk impedance contribution is only 8% to the total value even though its mass is 46% further undermines the validity of a conduction model wrist-ankle approach. Other investigators have used the segmental technique with similar results though the sum of the segmental resistances did not always appear identical to the total value by wrist-ankle method.[330;331] The criticism against the conduction model and the single frequency approach led the research towards the multifrequency Cole-Cole model that does attempt to address the heterogeneity of tissue conduction by using multiple frequencies and adopts the mixture theory to accommodate the non-conducting elements albeit inaccurately. The various methodologies were compared head-to-head by Gudivaka et al against isotope dilution techniques for accuracy of the regressed equations in normal individuals and in a separate normal subgroup receiving intravenous infusions once and diuretics 1-3 weeks later. The authors had concluded that the multifrequency Cole-Cole model was the better technique compared to the single/dual frequency models in individuals with altered hydration states[301].

The segmental bioimpedance approach evolved with the development of better analysers and algorithms that substituted individual segment resistance values into the volume model allowing for the calculation of segmental volumes. The segmental volumes were then added to give the TBW and ECF excluding the head and neck. This should be distinguished from earlier work of de Vries *et al* in which conductivity changes were measured in a single segment during ultrafiltration on dialysis[299].

3.5.4 Sum of segmental bioimpedance (SSBIS):

With advancement in technology it was possible to develop a digital switch (Zhu *et al*) allowing for the acquisition of segmental data sequentially from the upper limb, trunk, the lower limb and the traditional wrist-ankle configuration by deploying two more electrodes to the shoulder and hip. This allowed for measurement of ECF resistance and total body resistance in individual segments and then a summation of these component values to give the total body resistance.[332] This approach is not dissimilar to that adopted by Organ *et al* but did not measure compartment lengths, cross sectional area or used underwater weighing to calculate body density. The sum of resistances obtained were identical to that obtained by the wrist ankle method in the ten dialysis patients [332]. The work also explored the differences in ECF volumes pre- and post-dialysis when subjects were sitting or remained supine during dialysis. The wrist-ankle method systematically underestimated the weight loss during dialysis whereas the difference in ECF volumes pre- and post-dialysis measured by the segmental method was not significantly different to the UF volume and to the measured weight loss. The segmental method was also insensitive to positional changes measuring identical ECF volumes in both positions. The wrist-ankle method, on the other hand, tended to compute a lower ECF volume when subjects were sitting during dialysis. The authors alluded to the specific difficulties in the application of the wrist-ankle method to the dialysis population due to the greater propensity for unequal compartment volume distributions, asymmetry of limb volumes due to the presence of an arteriovenous-fistula and an exaggerated effect of gravity in terms of volume accumulation in the extremities. Also the effect of interstitial oedema in the pulmonary bed remains totally unaccounted for in calculations used in the wrist-ankle algorithm[333;334]. The equations involved in the segmental volume calculations are similar to that used in the wrist-ankle method. The significant difference being the constant used for measuring the volume of the trunk.

$$ECF_s = k_s Q_{ECF} (L^2/R) \quad (11)$$

where the constant k_s was defined as the weighting factor used to account for the inhomogeneity of current distribution in the measured segment. The upper limb and the lower limb have a value of 1 whereas the trunk is thought to have a value of 4 based on the authors' previous work in normal controls. The sum of segmental values is given by

$$ECF = 2(ECF_{UL} + ECF_{LL}) + ECF_{Trunk} \quad (12)$$

Even though the total resistance measured by the segmental method is identical to that measured by the wrist-ankle method; volumes derived from segmental method were more accurately reflective of the change in weight pre- and post-dialysis. The concept of normalised resistance, α , was introduced to explain the improved accuracy with the segmental method. Normalised resistance was defined as the change in resistance per unit change in ECF volume in the individual segment. In the wrist-ankle method the weighting of the arm and limb resistance exceeds that of the trunk even though the volume contribution of the trunk far exceeds that of the limbs. Measuring segmental resistance and then the segmental volume allows for a rational approach incorporating the inhomogeneity of current distribution in the trunk[334;335]. The insensitivity of the sum of segmental method to posture changes and a more accurate representation of volume loss during dialysis makes this technique of volume estimation more useful than the traditional whole body method in the dialysis population.

3.5.4.1 Utility of the SSBIS in dry weight assessments:

The segmental bioimpedance technique has been used by many researchers to measure the ECF volumes pre- and post-dialysis; Zhu *et al*, Carter *et al* [336], Song *et al* and others have explored its usefulness in monitoring fluid shifts, setting dry weights and defining fluid shifts between body compartments with posture changes and for measurement of trunk and abdominal cavity volumes in CAPD patients[337]. Song *et al* used the Mahalanobis distance (a scale used to distinguish among groups by means of multivariate data analysis) to distinguish between thoracic bioimpedance measured by the segmental method and the conventional whole body impedance in CAPD patients who were stratified based on

clinical assessments into euvoletic and the hypervolemic group with hypertension[338]. The authors measured the thoracic impedance by placing the voltage electrodes between the left wrist and the xiphisternum[339;340] leaving the current electrode placement unchanged from the whole body measurement. The whole body impedance index for the overhydrated group was significantly different to that of the clinically normovolemic groups. The thoracic segmental measurement however showed greater differences between the two groups and could identify differences in individual patients with better separation than the whole body method. Similar results were obtained by Zhu et al in their CAPD cohort[341]. In the haemodialysis population, a few studies have now compared whole body bioimpedance with the sum of segmental measurements and have commented on the increased sensitivity of the segmental method in identifying ECF volume changes and its higher correlation with weight changes and UF volumes[342-344].

However there remains the vexing issue of predictive accuracy for pre-dialysis TBW and ECF estimates that will allow the clinician to aim for a dry weight consistent with euvoemia. The mean difference between ECF measured by gold standard isotope dilution technique and sum of segmental bioimpedance is 1-2L. The differences are higher for ICF volumes when compared with values obtained from total body potassium analysis. One of the reasons for the inaccuracies with the segmental method is thought to be the assumption of uniform segmental resistivity values across the measured segments. In the dialysis population, differential ECF volume expansion in body segments may result in small but significant changes in conductivity and therefore will need to be accounted for in volume equations. The other reason for the discrepancy could be the effect of the body composition of subjects in the reference population and dialysis cohorts that may skew the ECF calculation to be an underestimate of the true value as measured by dilution methods.

3.5.5 Applicability of bioimpedance techniques in altered hydration states:

A decade after the initial technology review, Kyle *et al* [345;346] reporting for the European Society for Clinical Nutrition and Metabolism (ESPEN) summarised the clinical relevance of bioimpedance technologies in use in 2004. The authors commented on the reference populations used by various investigators and the bioimpedance technique used for volume calculations. The reference methods used

were DEXA, Under Water Weighing (UWW), isotope dilution techniques in the various studies. Most studies were done in healthy individuals with age ranges between 16-94 years. More than 2500 subjects had been studied for TBW estimations using predictive equations whose standard error of estimation varied between 1.3 and 3.8L. The SEE of ECF with various predictive equations varied between 0.98 to 3L in more than 500 subjects with similar age distributions. ICF estimations with multi-frequency bioimpedance analysers in 216 patients in two studies showed a SEE of 0.9 to 1.9L. The reference method used was TBK⁴⁰ estimation. The subjects in these studies were mostly Caucasian apart from one of the larger groups studied by Sun *et al* [347] that included African-Americans and Kotler *et al* who studied ethnic divers[348].

The authors had pointed out a few factors as significant shortcomings of the predictive equations including ethnicity, body mass index, and the distinct lack of subjects in these studies who had altered hydration states. In a follow up to these observations, the authors also reviewed the literature for use of various bioimpedance techniques in disease states. The study by Chertow *et al* in 3009 HD patients was not included in the review but remains the largest bioimpedance study in the dialysis population. Patients were recruited from Fresenius run renal units across North America and had their Body Mass Index (BMI), Total Body Water (TBW), Resistance (R), Reactance (X_c), Phase Angle (PA) studied using a single frequency instrument (BIA Quantum, RJL Systems, Michigan, USA). The reported correlation coefficient was 0.2 - 0.45 between the PA and body cell mass (BCM) and other nutritional parameters like albumin, pre-albumin and creatinine. The study reported a 'normal range' for PA in dialysis population, noting that <10% of these patients had PA s different to that of a normal population. PA varied between 5.62° to 3.97° in different age groups with a larger value (less narrow) in younger patients[349].

The ESPEN group reported on four other studies, where, TBW/ECF or phase angle was measured in 153 HD patients using multi-frequency Cole-Cole model or bioimpedance vector analysis (BVA). The BVA method, (Maggiore *et al*) [350], was useful as a prognostic indicator while the SEE of TBW/ECF by the Cole-Cole model ranged between 6-7% in the study of 16 patients by Ho *et al* [351] and a huge 15-25% variation in ICF measurements in the smallest study of 6 patients (Scharfetter *et al*)[352]. The sum

of segmental approach was noted to be insensitive to changes in posture and more accurate in measuring changes in ECF pre- and post-dialysis.

In the CAPD cohort, 200 patients were studied using the BVA technique by the Piccoli & Italian CAPD BIA group observing that the impedance vector tended to be associated with a lower phase angle in overhydrated patients and the significance in terms of prognosis needed longitudinal evaluation.[353] In addition to studies in the dialysis population, patients with CKD were also studied by Piccoli and Bellizzi among others, again, relating a lower phase angle to worse prognosis[354].

The review highlighted the need for volume data obtained through reference techniques (isotope dilution) in a large population with altered hydration states. The sum of segmental approach needed further evaluation. The resistivity values from the normal population were thought to be inaccurate when applied to volume expanded states. Furthermore, the limitations of the WBIA were emphasised noting its insensitivity to volume changes in the trunk and its susceptibility to positional changes when calculating ECF changes pre- and post-dialysis. The BVA method was felt to be more of a prognostic tool.

3.6 Modification of the Col-Cole algorithm for altered hydration states:

Some of the above mentioned shortcomings were addressed by various investigators by modifying the volume calculations derived from the Cole-Cole model.

Matthie *et al* had presented their modelling equations for volume calculations using the Cole-Cole model in 1990[326] that was later published by De Lorenzo in 1997. In 2000, a modification to the equation was introduced to minimise errors in the calculation of ICF. This was later published as the second generation equation by the original authors in 2005[324]. The extrapolation of the low frequency end of the impedance locus gives the ECF resistance as described previously. The relationship between R_{ECF} and ECF volume was proposed to be a simple non-linear mixture effect involving two spaces, conductive and non-conductive. At the extrapolated higher frequency end of the impedance locus, the TBW resistance (R_{TBW}) was related to the volume by a non-linear mixture effect involving ECF, ICF and the non-conducting component. Calculations of the TBW require a resistivity value (ρ_{TBW}) that is indirectly

derived based on the ratio of the ECF/ICF compartments and assuming a linear mixture effect of the individual ECF and ICF resistivities based on the ratio of their relative volumes. However the authors reported this to be erroneous and stated that the ICF resistivity was up to 3-4 times higher than that of the ECF, based on the seminal work of Geddes and Baker in 1967, who had described resistivity characteristics of all body fluids[286]. A change in ρ_{TBW} estimation, therefore, was required to account for the increased resistivity of the ICF compartment. A new series of equations for the calculation of ICF were developed as below.

$$V_{TBW} = \frac{1}{1000} \left(\frac{\rho_{TBW} * K_B * Ht^2 * \sqrt{W}}{D_B * R_{INF}} \right)^{\frac{2}{3}} \quad (13)$$

$$V_{ECF} = k_{ecf} \left(\frac{\sqrt{W} * Ht^2}{R_E} \right)^{\frac{2}{3}} \quad \text{where} \quad (14)$$

$$k_{ecf} = \frac{1}{1000} \left(\frac{\rho_{ECF}^2 * K_B^2}{D_b} \right)^{\frac{1}{3}} \quad (15)$$

ρ_{TBW} and ρ_{ECF} represented total body water (TBW) and extracellular fluid (ECF) resistivities, respectively.

K_B , was an anthropometric constant ; Ht , the height of subject; D_B , the density of the human body; W , the weight of the subject; R_E and R_{INF} , the modelled extrapolated resistances at '0' and 'infinite' frequencies respectively

The constant k_{ecf} was defined based on sodium bromide (NaBr) dilution studies for ECF and deuterium dilution (D_2O) for TBW measurements in healthy individuals. A value of 0.3 and 0.316 was quoted by authors from their previous work. From these values, the apparent resistivity of ECF was computed and from it the true ECF resistivity using the Hanai mixture theory.

Dividing equation 13 by 14 gives a following simplified equation

$$\frac{V_{TBW}}{V_{ECF}} = \left(\frac{\rho_{TBW} * R_E}{\rho_{ECF} * R_{INF}} \right)^{\frac{2}{3}} \quad (16)$$

V_{TBW} is the arithmetic sum of ECF and ICF compartment volumes,

$$V_{TBW} = V_{ECF} + V_{ICF} \quad (17)$$

By the parallel law of resistance summation, the extrapolated resistance at infinite frequency representing the TBW resistance (R_{INF}) is given by

$$\frac{1}{R_{INF}} = \frac{1}{R_E} + \frac{1}{R_I} \quad (18)$$

Where R_E and R_I represent resistances of the ECF and ICF compartments respectively. It is to be noted that at high frequencies the effect of the cell membrane capacitance (C_m) is zero and hence there is no capacitive reactance in the summation; the total impedance becoming a resistance parameter determined by the resistivities and volumes of the ECF and ICF compartments.

Further simplification of Equation 18 gives

$$R_{INF} = \frac{R_E * R_I}{(R_E + R_I)} \quad (19)$$

Substituting, V_{TBW} in equation 16 with its expansion as per equation 17; and, replacing R_{INF} with its equivalent ECF and ICF resistances as per equation 19; gives,

$$\frac{V_{ECF} + V_{ICF}}{V_{ECF}} = \left(\frac{\rho_{TBW} * (R_E + R_I)}{\rho_{ECW} * R_I} \right)^{\frac{2}{3}} \quad (20)$$

Further rearrangement gives a value for V_{ICF} as

$$V_{ICF} = V_{ECF} * \left\{ \left(\frac{\rho_{TBW} * (R_E + R_I)}{\rho_{ECW} * R_I} \right)^{\frac{2}{3}} - 1 \right\} \quad (21)$$

The authors had then used the Hanai mixture theory defining conductivity of an emulsion (in this case TBW) that was constituted by two different liquids (ECF and ICF respectively) with different conducting properties. At high current frequencies, the lack of cell membrane capacitance, allows for the application of this version of the theory, as opposed to, see below.

This should be differentiated from the earlier discussions exploring the effect of a non-conducting component of volume 'C' (analogy with the ICF compartment at low current frequencies when the cell membrane capacitance imparts a non-conducting property to the contained ICF fluid) on the total resistance of a conducting fluid resulting in an apparent resistance, ρ , as opposed to its true resistance, ρ_0 . ($\rho > \rho_0$).

In brief, if the fraction of ECF and ICF constituting TBW were represented by C_{ECF} and C_{ICF} ; then

$$C_{ICF} + C_{ECF} = 1 \quad (22)$$

The Hanai mixture can be represented in terms of the fluids' conductivities as

$$1 - C_{ICF} = \left(\frac{\sigma_{TBW} - \sigma_{ICF}}{\sigma_{ECF} - \sigma_{ICF}} \right) * \left(\frac{\sigma_{ECF}}{\sigma_{TBW}} \right)^{\frac{1}{3}} \quad (23)$$

Where, σ represents conductivity of TBW/ICF/ECF as denoted by the subscript respectively.

Substituting the conductivity parameters by their reciprocal resistivities and further simplification yields

$$1 - C_{ICF} = C_{ECF} = \left(\frac{\rho_{ICF} - \rho_{TBW}}{\rho_{ICF} - \rho_{ECF}} \right) * \left(\frac{\rho_{TBW}}{\rho_{ECF}} \right)^{\frac{2}{3}} \quad (24)$$

But
$$C_{ECF} = \left(\frac{V_{ECF}}{V_{ECF} + V_{ICF}} \right) \quad (25)$$

And the parameter on the right hand side of Equation 25 has already been defined earlier in Equation 20 and therefore,

$$C_{ECF} = \left(\frac{\rho_{ECW} * R_I}{\rho_{TBW} * (R_E + R_I)} \right)^{\frac{2}{3}} \quad (26)$$

Substituting the parameter from Equation 24 into Equation 26 results in

$$\left(\frac{\rho_{ICF} - \rho_{TBW}}{\rho_{ICF} - \rho_{ECF}}\right) * \left(\frac{\rho_{TBW}}{\rho_{ECF}}\right)^{\frac{2}{3}} = \left(\frac{\rho_{ECW} * R_I}{\rho_{TBW} * (R_E + R_I)}\right)^{\frac{2}{3}} \quad (27)$$

That after simplification gives the revised equation for ICF resistivity

$$\rho_{TBW} = \rho_{ICF} - (\rho_{ICF} - \rho_{ECF}) * \left(\frac{R_I}{R_E + R_I}\right) \quad (28)$$

Sequentially solving equations 13,14,21 and 24 will yield the ICF volume.

The second generation equation has been widely recognised by other investigators in the nutrition and body composition field. Its applicability in the dialysis population is still susceptible to errors as the initial work leading to the development of the apparent and true ECF and TBW resistivities was conducted in a small group of healthy subjects.

Jaffrin *et al* [355] defined TBW resistivities in 58 healthy volunteers through the extrapolated resistance at infinite frequency (R_{INF}) using the BIS method and fat free mass (FFM) measured by dual energy X-ray absorptiometry (DEXA). A hydration index of 73.2% was used to calculate TBW from FFM. The authors used a direct approach to calculate the TBW based on the R_{INF} value obtained from the BIS device (Xitron 4200). This is different to the method described by De Lorenzo and Matthie that required the calculation of intracellular resistance (R_I) from the extrapolated values at zero and infinite frequencies and then a proprietary equation to calculate ICF and then the TBW as an arithmetic sum of ECF and ICF. The authors used the ECF equation described by De Lorenzo by substituting the ECF resistivity with TBW resistivity that was then analysed for accuracy using the DEXA derived TBW from FFM. In brief from Hanai's mixture theory, at high frequencies, as mentioned previously, the apparent resistivity of the TBW component will be related to the true resistivity when a non-conducting fraction 'c' is present, as below

$$\rho_a = \frac{\rho_{\infty}}{(1 - c)^{\frac{2}{3}}} \quad (29)$$

where ρ_a and ρ_∞ are the apparent and true resistivities at infinite frequencies respectively

If the total body volume was V_b , inclusive of FFM incorporating TBW and the fat mass (FM), then,

$$c = 1 - \frac{TBW}{V_b} \quad (30)$$

Substituting this in Equation 29 results in

$$\rho_a = \rho_\infty \left(\frac{V_b}{TBW} \right)^{\frac{3}{2}} \quad (31)$$

The TBW resistance (as calculated at extrapolated infinite frequency, R_{TBW}) can be related to the total body volume through the modified impedance index described earlier (Equation 8). This assumes an intimate mixing effect between ECF and ICF compartments rather than the discrete existence proposed by Cole[296], Frick, Geddes and De Lorenzo[327], connected in parallel configuration with the separation offered by membrane capacitance at low frequencies. This assumption also requires a linear mixing effect resulting in a TBW resistivity determined by the proportional volumes of ECF and ICF.

$$R_{TBW} = \frac{K_B * \rho_a * Ht^2}{V_b} \quad (32)$$

Replacing ρ_a with value in Equation 31 yields

$$R_{TBW} = \rho_\infty \left(\frac{V_b}{TBW} \right)^{\frac{3}{2}} * \frac{K_B * Ht^2}{V_b} \quad (33)$$

Further rearrangement results in a familiar volume equation with an unknown parameter, ρ_∞ that can be calculated from the measured R_{TBW} and DEXA derived TBW.

$$TBW = \left(\frac{\rho_\infty * V_b^{\frac{1}{2}} * K_B * Ht^2}{R_{TBW}} \right)^{\frac{2}{3}} \quad (34)$$

The volume parameter, V_b can be re-written as $\frac{W}{D_b}$, representing weight and density respectively. This equation is remarkably similar to that derived by De Lorenzo for ECF volume calculation. Jaffrin *et al* had alluded to the relative simplicity of their equation for calculation of TBW and attempted to standardise the TBW resistivity (Q_{TBW} or Q_∞) by substituting the DEXA derived TBW in equation 34 and calculating Q_{TBW} in each individual subject.

$$\rho_\infty = \left(\frac{TBW^{\frac{3}{2}} * R_{TBW}}{V_b^{\frac{1}{2}} * K_B * Ht^2} \right) \quad (35)$$

TBW in this instance is that determined from DEXA

$$TBW = 0.732 * FFM_d \quad (36)$$

An average Q_{TBW} of healthy study group of men and women was then used to calculate the TBW from equation 35. The Xitron device measured the resistance at 1MHz and the Cole model provided its extrapolated equivalent at infinite frequency. (R_∞ or R_{TBW}). This was postulated to be a more accurate method of determining the TBW compared to the proprietary (unpublished) ICF/TBW equations provided by the manufacturers of the Xitron device and the De Lorenzo equation previously mentioned (Equation 9).

In their original publication, De Lorenzo *et al* [327] had used the Cole model to calculate extrapolated resistances at zero and infinite frequencies from the measured resistances at 5KHz and 1MHz. This was followed by the calculation of ICF resistance (R_{ICF}) from the extrapolated values using the circuit model with ECF resistance and ICF resistances arranged in parallel. Any inherent error in the extrapolation step will be magnified in the second stage of ICF resistance estimation. The third step is the calculation of respective ECF, ICF and TBW resistivities. TBW resistivity was thought not to be just an average of ECF and ICF resistivities but an entity dependant on relative ratios of ECF and ICF and a scaling fraction obtained from D₂O and NaBr dilution techniques balancing a probable difference in conductivities of ECF and ICF solutions consequent to their significantly different ionic content. This scaling factor was

called k_{ECF} in their technology review. The result is that ,the Xitron or De Lorenzo equation systematically underestimates ICF volume, thereby undermining the accuracy of the TBW . It does retain a high degree of accuracy for ECF at least in the normal reference population. Jaffrin *et al* had suggested that their TBW equation avoided these errors to a large degree as their new equation was based on the De Lorenzo ECF equation using the extrapolated R_{∞} rather than R_0 for TBW. This however requires TBW to be a homogenous compartment at a macroscopic level.

The authors then compared the weight loss data of 28 haemodialysis patients (RWL, real weight loss, UF volume V_{uf}) with TBW data pre- and post-dialysis measured by their new method (V_{tmm} , using average TBW resistivities obtained from DEXA estimated FFM in healthy volunteers), that obtained from Xitron 4200 using the manufacturer supplied proprietary equation (V_{tx} , and that obtained by using the original De Lorenzo equation (V_B). The V_{tmm} method more accurately predicted RWL than the other two methods. This was inspite of the fact that an average ρ_{TBW} from healthy subjects was used. The downside of treating TBW as a homogenous medium comprising of ECF and ICF means individual compartment volume changes cannot be absolutely determined by the method.

3.7 A bridge from BIA to BIS

Jaffrin and Morel[356] also proposed a newer technique to calculate TBW from their equation above, however, by substituting R_{TBW} with a parameter called R_{t50} . This was derived by measuring resistance at the infinite frequency and also at 50 KHz. The aim was to explore the possibility of extrapolating the value obtained at 50 KHz to that at R_{∞} using a correction coefficient. The proposed advantage, therefore, was that the resistance data obtained at 50 KHz could be converted to its equivalent R_{∞} value and then used in Equation 34 to calculate TBW. This method was seen as a bridge between the single and multifrequency bioimpedance techniques. The correction coefficient was calculated by measuring R_{∞} and

R_{50} in 57 healthy subjects. The average ratio $\frac{R_{50}}{R_{\infty}}$ for men and women was taken to be the correction coefficient, b . The result obtained by dividing the individual R_{50} of each subject by ' b ' was termed R_{t50} , that was then substituted in equation 34 above to calculate TBW (designated V_{td}). The authors reported a high correlation between this method and their previous method (V_{tn}) described above. Furthermore, the

TBW was also compared with the statistical equations of Kushner and Schoeller[357], Hannan *et al* [358]and Deurenberg [359]. The Kushner equation results were not significantly different from V_{td} for men but were for women. The Hannan and Deurenberg equations gave significantly different results.

The calculation of TBW by these methods may be accurate in healthy individuals with no alterations in the ECF to ICF ratios, but are of limited usefulness when used in altered hydration states, particularly in the dialysis population. The inability of these methods to distinguish the proportional change in ECF and ICF volumes as a result of fluid retention, in between dialysis sessions, limit their usefulness as volume management tools.

3.8 Bioimpedance methods for volume management in the dialysis population:

The volume of work in the dialysis field using the various bioimpedance techniques (single vs multifrequency, whole body vs segmental, sum of segmental BIA) highlights the difficulties in using a single technique or method to evaluate the fluid state of a dialysis patient. The earlier works had predicated on using bioimpedance as a volume measurement tool with data obtained from isotope dilution methods in mostly small healthy populations defined as the reference group. The correlations obtained between weight losses during dialysis and changes in ECF pre- and post-dialysis have not been strong enough to prefer one bioimpedance method over another. Any technique promising to be useful as a hydration assessment should non-invasively be able to predict the required weight loss to achieve euvolemia. Reaching a normal hydration state after a dialysis session depends on numerous factors including compliance with fluid and salt restriction, minimal use of hypotensive agents, robust cardiac function, age and dialysis parameters such as membrane biocompatibility, relatively longer sessions, reasonable UF rates and adequate dialysis access. The following techniques have been shown to be useful in the dialysis population for the estimation of the dry weight.

3.8.1 Floating dry weight method (Chamney *et al*)[360]

Whole body bioimpedance using the Xitron 4200 was used to calculate ECF volumes in 68 healthy subjects (35 male) with a mean age of 31 and a mean weight of 70.9 kg (range 14.5-120kg). The ratio of

their ECF volumes and weights (W) was calculated to create a reference plot (slope normovolemia, S_{NV}).

A dialysis patient with volume overload would have an altered $\frac{ECF}{W}$ ratio that can be represented on the S_{NV} plot.

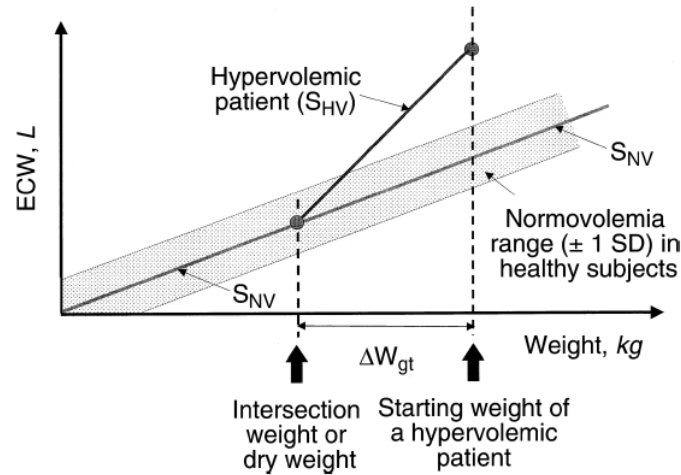

Figure 3.5: Relationship between normovolemia and hypervolemia with respect to dry weight

S_{NV} : Slope normovolemia, from reference population S_{HV} : Slope of a volume overloaded dialysis patient
With progressive weight reductions (ΔW_{gt}), S_{HV} intersects S_{NV}

Reproduced with permission from

Chamney et al Kidney International, Vol. 61 (2002), pp. 2250–2258

It is to be noted that for every litre of fluid removed weight falls by 1 kg. The density of ECF is very close to unity. Therefore S_{HV} will have a value of 1L/Kg. As volume is removed by UF the S_{HV} will ‘move’ towards S_{NV} eventually intersecting it. The weight at which the intersection occurs is taken to be the dry weight.

The slope of this hypervolemic state (S_{HV}) can be represented as

$$S_{HV} = \frac{ECF_m - ECF_{NV}}{W_m - W_{dry}} \quad (37)$$

where ECF_m is the measured ECF by Xitron, W_m is the weight of the dialysis patient and ECF_{NV} and W_{dry} represent the ECF and weight of the subject at the euvoletic state.

ECF_{NV} can be derived from the reference relationship as

$$S_{NV} = \frac{ECF_{NV}}{W} \text{ and } ECF_{NV} = S_{NV} * W \quad (38)$$

Substituting and rearranging in equation 37 gives

$$W_{dry} = S_{HV} * W_m - ECF_m / S_{HV} - S_{NV} \quad (39)$$

This relationship can be used to achieve weight decrements over a few dialysis sessions in patients starting dialysis and also in prevalent patients who may have lost lean body mass during periods of intercurrent illnesses. It should be emphasised that the normal population will exhibit a standard deviation in their S_{NV} and therefore there would be an area of uncertainty in the estimation of the dry weight as the S_{HV} tends to intersect the S_{NV} plot.

In the thirteen incident dialysis patients this principle was applied to predict euvolemia, a mean reduction in body weight of 5.6% was achieved along with a significant reduction in mean arterial pressure (MAP) and 86% reduction in anti-hypertensive drug usage.

This technique remains one of the easiest ones to use as long as the data from a reference healthy population is available. It is also possible to develop reference data for different age groups and different body mass indices. This may, however, be its Achilles heel, as the onus is on the operator to develop a large enough database encompassing different population subgroups. The assumption that the overhydration consequent to ESRD is predominantly limited to ECF may not be true in all dialysis patients. Lastly the lack of large reference dialysis population in whom isotope dilution has been performed limits the accuracy of the ECF estimation by the Xitron 4200.

3.8.2 The RX_c Graph

Piccoli et al[302;353;361;362] had commented on the usefulness of representing the single frequency (50 KHz) resistance-reactance data ($R-X_c$) in its vectorial form with the amplitude and phase angle of the resultant impedance vector falling in discrete elliptical areas dependant on the hydration state of the patient. The ellipse of normality was derived from 86 healthy subjects (38 males, 16-66 years) and compared with disease states varying from dehydration, nephrotic syndrome and ESRD along with

obesity. The impedance vector was outside this ellipse of normality in various disease states. When fluid state was normalised either by dialysis or diuretic use or patients with relapsed nephritic syndrome going into remission, the impedance vector shortened with volume loss entering the ‘ellipse of normal hydration’.

The ellipse for the reference population is bivariate and gender specific and needs to be derived from a large group to narrow the 50,75 and 100% rings of probability . This can then be used to confidently predict attainment of euvoemia with a shortened vector length. This method was used by Maggiore *et al* to predict survival outcome in 131 HD patients with patients whose phase angles falling within the lowest quartile exhibiting poor survival, the implication being that these patients remained fluid overloaded. A similar outcome was demonstrated in the CAPD population by Piccoli, measured in 200 patients, with changes in phase angle in response to fluid removal resulting in the impedance vector migrating towards the ‘normal’ ellipse. The patients in whom this was difficult to achieve did poorly[350].

This method uses single frequency bioimpedance equipment and is easy to use once the reference population has been studied. It is also elegant in its approach that does not add the layers of logical conjecture inherent in the volume equations used in multifrequency bioimpedance analysis. However, as before the reference population needs to be large and ethnicity, age and gender should be represented in sufficiently large numbers to minimise the area of the ‘normal’ ellipse.

3.8.3 Real time monitoring using Cont SBIS (CSBIS Technique)

An important consideration when striving to achieve euvoemia in the dialysis population is the phenomenon of vascular refill. This relates to the ease with which fluid shifts from the ECF into the intravascular compartment during a dialysis session. The rapidity of ECF mobilisation determines haemodynamic stability. The current trend of intermittent short duration thrice weekly haemodialysis puts enormous pressure on this regulatory mechanism as the UF rates often exceed the filling rates. One strategy to minimise intra-dialytic symptoms of hypotension will be tailoring the UF rates in line with the refill rate. This will indirectly encourage achievement of euvoemia if the refill rate is maximised through a dialysis session and the ECF compartment normalised at the end of dialysis.

Monitoring this ECF emptying can be done without recourse to the volume modelling of bioimpedance data by simply measuring the ECF resistance change continuously in a segment.

As mentioned before, the segmental bioimpedance multifrequency technique can be adapted to be used continuously through a dialysis session with the Xitron 4200. Previous work by Zhu *et al* has demonstrated its accuracy when measuring in supine, sitting and standing postures[334]. The rapidity of change in ECF resistance during fluid removal can also be detected by the CSBIS technique with data capture every 10-15 seconds. Work by the same author's group in detecting changes in calf resistance whilst inflating and deflating a blood pressure cuff had demonstrated rapid changes in the R_{ECF} tracing that return to a pre-event negative slope when the stimulus is switched off. (Figure 3.6)[363]

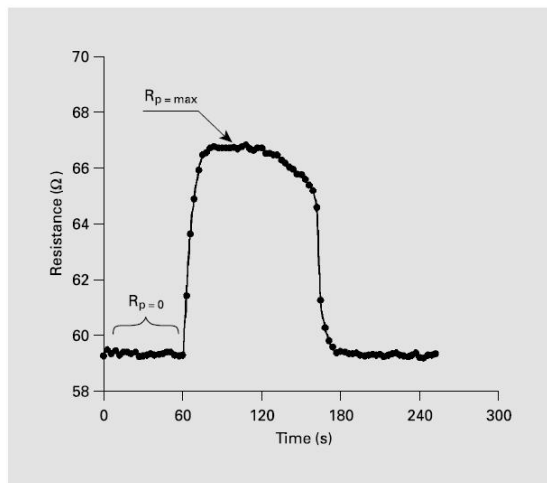

Figure 3.6: Change in calf ECF

Example of a change in calf ECF resistance on application and release of a blood pressure cuff

R_p ECF resistance response to pressure, '0' when cuff deflated, 'max' when inflated above systolic pressure

(reproduced with permission from Zhu et al ; Blood Purif 2003;21:131-136)

Monitoring the calf resistance during dialysis with electrode placement on the anterolateral aspect of the lower leg shows a rise in the measured R_{ECF} with fluid removal. Assuming the value of R_{ECF} as R_0 at the

start of dialysis and R_t at time 't' into dialysis; the ratio $\frac{R_0}{R_t}$ when plotted against time will be representative of the ECF volume loss. This is represented as a composite change in 10 patients in Figure

3.7

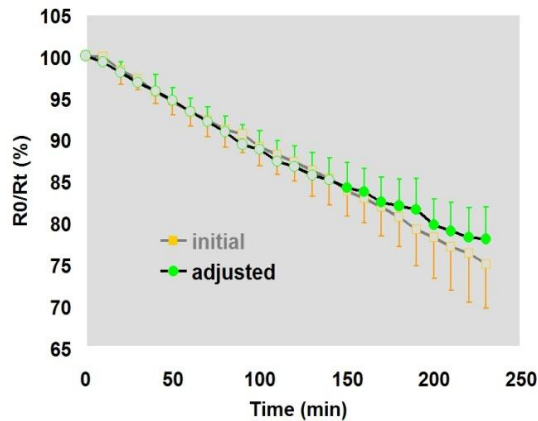

Figure 3.7 : Resistance Ratio

Changes in R_0/R_t profile through dialysis at different dry weights (pooled data of 10 patients)

A greater fall in R_0/R_t with lower dry weights

Reproduced with permission from Zhu *et al*, personal communication

Work by Zhu *et al* and ourselves in the dialysis population has shown the curve to have exponential characteristics during the initial third of dialysis transforming itself to a linear decay towards the latter half of dialysis[364]. It could be speculated that duration of the exponential part may be indicative of the degree of hyperhydration and the onset of linearity indicative of rapidly slowing vascular refill. The

achievement of time versus $\frac{R_0}{R_t}$ slope zero is indicative of cessation of vascular refill. Further attempts at UF will almost certainly precipitate hypotension.

The CSBIS method is simple enough to be performed by the bed side repeatedly and data can be represented in real time to institute changes in UF rates and subsequent adjustments to the dry weights. However environmental factors like stray interference, temperature, proximity to unearthed metallic objects and patient specific factors like skin conductivity, cutaneous vasoconstriction, variations in core temperature, gravitational effects and ‘capture fatigue’ may all introduce noise into captured data. These effects may be significantly increased towards the end of the dialysis session when the ECF volume is close to being normal.

3.8.4 Dual Compartment monitoring (CSBIS and RBV)

The accuracy of ECF monitoring can be complemented by simultaneous RBV monitoring. RBV changes on their own have been difficult to interpret in terms of the fluid state as the ECF compartment events largely determine vascular stability. The existence of a ‘crash crit’- the lowest RBV value at which haemodynamic compromise occurs has been proven to incorrect in many patients, particularly the elderly.

The RBV trends of a single dialysis session is unrepresentative of the fluid state and even data from multiple sessions at best allude to volume removal during dialysis rather than normalisation of body volume compartments.

However, if pulse UF is employed with high rates for short duration and a period of isovolemic HD ensues, it is possible to clearly demonstrate volume rebound. This blunting of volume rebound is more likely to represent the onset of normovolemia unless of course the vascular refill is compromised.

Employing pulse UF towards the latter third of HD along with CSBIS-RBV monitoring will reliably demonstrate the surplus volume in the ECF in association with a brisk rebound if the subject's dry weight is inappropriately high. This method also obviates the need for extending a dialysis session to look for

RBV rebound. If the $\frac{R_0}{R_t}$ curve is flattened with a zero slope (horizontal trace), then, vascular refill has ceased, either due to the attainment of normovolemia or failure of the process due changes in venous tone brought about by UF and the associated compromise of compensatory mechanisms. On the other hand a continuing negative $\frac{R_0}{R_t}$ slope will mean persistent overhydration and may warrant further pulses of UF to reach the correct dry weight. The monitoring of the ECF compartment provides better credence to changes in the RBV and goes some way in addressing the limits of RBV monitoring (underestimation of total blood volume changes, altered F_c ratio, postural changes etc).

There is also the opportunity to repeatedly study vascular refill patterns through the segmental monitoring and institution of rational measures that can optimise this aspect of UF by individualised UF prescriptions, isothermic dialysis with simultaneous sodium profiling. Example of a profile with combined ECF and RBV monitoring is illustrated (Figure 3.8 with uniform UF and Figure 3.9 with Pulse UF)

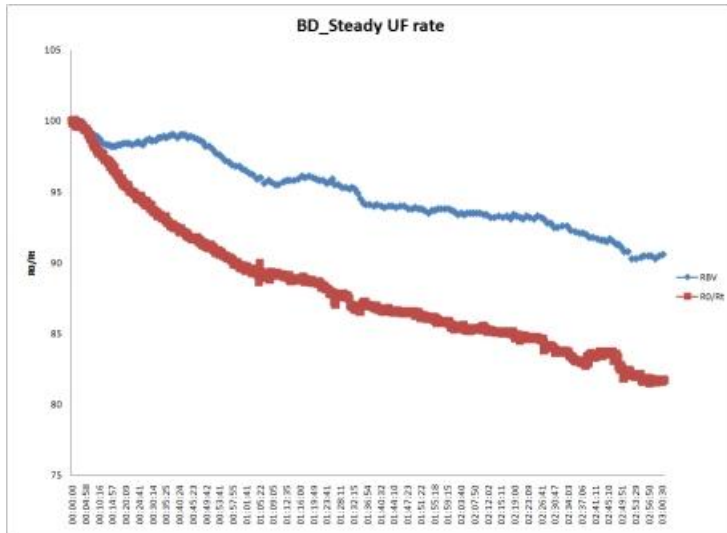

Figure 3.8 : RBV-Resistance ratio

Example of dual compartment monitoring, red line represents changes in the R_0/R_t and blue line the change in RBV mapped against time of dialysis session (Personal data)

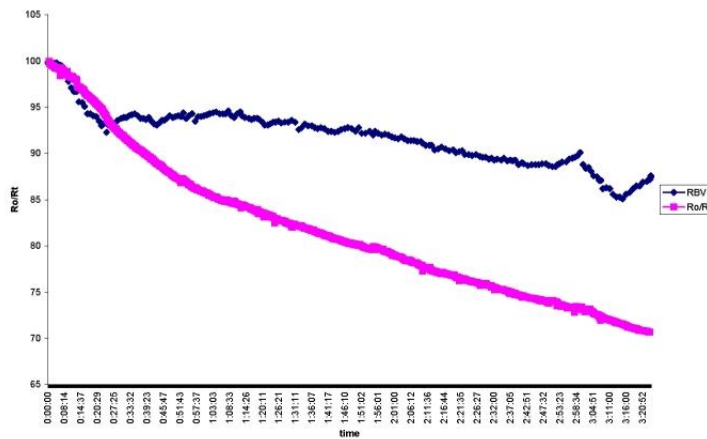

Figure 3.9: RBV-Resistance ratio trace during pulse UF

Profile from dual compartment monitoring with Pulse UF at start and end followed by isovolemic HD to assess rebound (Personal data)

3.9 Conclusion

Bioimpedance is a simple non-invasive tool to measure ECF and TBW in healthy subjects. Its utility in altered hydration states is debatable. Over the last twenty years, various flavours of the technique have

found increasing use in the fields of nutrition, body composition, sports medicine and dialysis. The continuing debate between the merits of the single frequency and multifrequency methodologies shows no sign of abating. Multifrequency model purports to be based on sound electrical principles with due consideration given to the incredible complexity of the electrical path in the human body. The single frequency method relies on regressed equations derived from data obtained from dilution techniques. A similar approach has also been necessary to derive the volume equations in the multifrequency method. These equations have been derived largely by the engineering community with the clinician being the end-user not entirely aware of either the complexity or the assumptions made in their derivation. It is now considered essential, at least, in the dialysis population to adopt a segmental approach to calculate volumes, to include the large surface area of the trunk and its lower impedance contribution. This however introduces complexity to the data collection that will not lend itself to routine use in a dialysis unit. At present sum of segmental approach is used in a very limited number of centres and its use in mainstream clinical practice will require simplification of the measurement approach.

The use of raw resistance data has been favoured by many investigators including this author for its simplicity. Relating the measured resistance data to a volume state requires further manipulations of the data and repetitiveness of its application to arrive at a sensible predicted dry weight for each individual patient. Having a reference graph of 'normality'; either the R-Xc or the floatind dry weight approach improves user friendliness and accuracy as long as the 'normal' population is well defined.

Dual compartment monitoring allows for logical interpretation of the fluid movement between compartments when coupled with pulse ultrafiltration in the latter third of a dialysis session. Assuming that, patient, equipment and environment related factors can be optimised; this promises to be the most simple and direct application of the current bioimpedance technology.

The studies described in the subsequent chapters aim to test the validity of dual compartment monitoring and ascertain its limitations in prevalent HD patients. It will be shown that the technique is easily applicable at the bed side and has the potential to be interpreted in real time. It is also hoped that the onset of IDH can be predicted and prevented in future applications of the technique.

A summary of available Bioimpedance techniques is given in Table 3.2

Table 3.2 : Available bioimpedance technologies

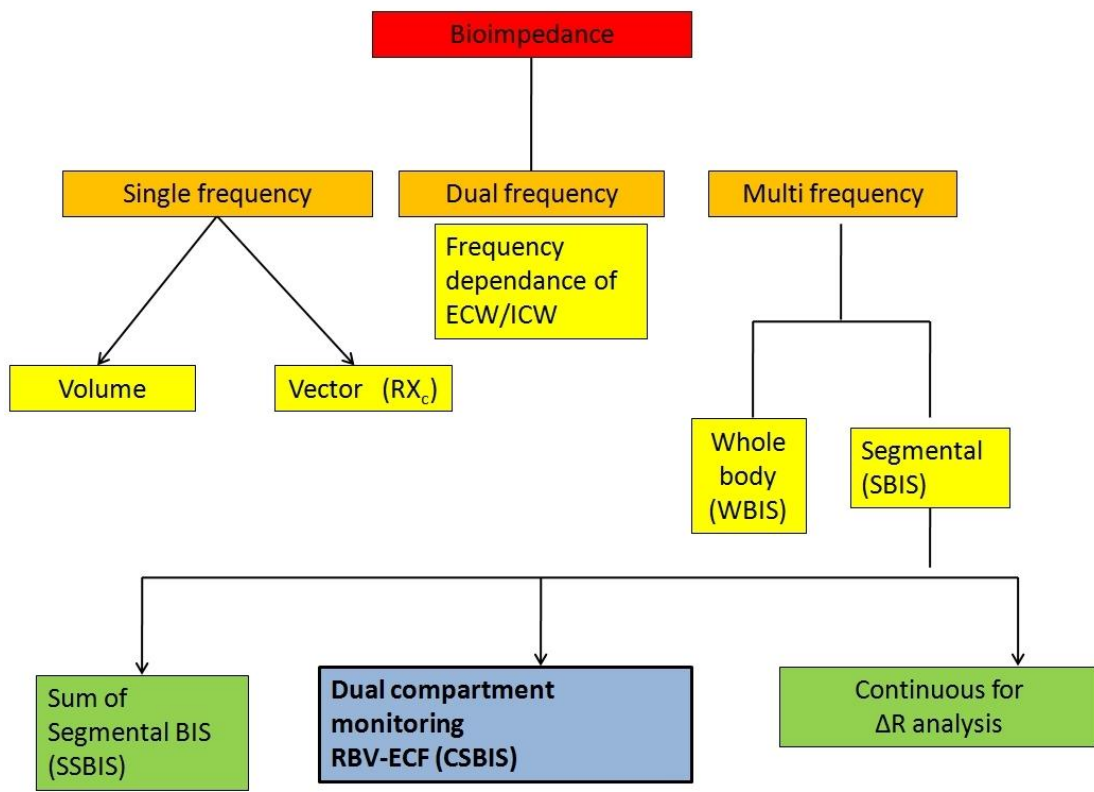

Chapter 4

Natriuretic peptides

4.1 Introduction

The natriuretic peptide family consists of four structurally similar but genetically distinct molecules with pronounced cardiovascular and renal actions. They are counterregulatory hormones playing an important role in fluid volume homeostasis. Atrial natriuretic peptide and B-type natriuretic peptide cause diuresis, natriuresis and vasodilatation. C-type natriuretic peptide has anti mitogenic effects and causes vascular smooth muscle relaxation. Dendroaspis natriuretic peptide shares many of the actions of ANP and BNP but its function in humans is not yet fully understood. Natriuretic peptides have been extensively investigated as biochemical markers of the fluid state. Levels are elevated in disease conditions characterised by fluid overload and are closely related to survival in various cardiac disease states. In the dialysis population BNP correlates significantly with cardiac function whereas ANP is sensitive to volume changes during dialysis. However changes in concentration do not predict achievement of euvolemia and short half-life combined with complicated assay techniques make ANP a less than satisfactory tool for assessing hydration. BNP is a superior prognosticator for risk stratification in dialysis patients and serial estimations will help in the identification of occult cardiac disease.

4.2 The discovery of natriuretic peptides

In 1981 de Bold[365] and his colleagues homogenised the extracts of atria and ventricles of rats and intravenously injected either the atrial or ventricular extracts into anaesthetised rats. The injection of the atrial homogenate produced profound diuresis and natriuresis while the injection of ventricular homogenate did not alter these parameters. The substance responsible was later named ANP and its structure was identified in 1984[366]. Since then there has been a proliferation of interest in natriuretic peptide research leading to the discovery of three more peptides named BNP, CNP and DNP[367-370]. BNP and CNP were isolated from the porcine brain and DNP was isolated from the venom of the green mamba snake in 1992. (*Dendroaspis angusticeps*). [371;372] These discoveries firmly established the heart as an endocrine organ also confirming the long held notion of the presence of a humoral link between the heart and the kidney. More recently Kitamura et al[373-375] have isolated another vasodilatory peptide

exactly similar to ANP and BNP[399-402]. Adrenomedullin is a 52 amino acid peptide released from the adrenal medulla, kidney and endothelium of large blood vessels and possessing actions very similar to ANP causing hypotension, vasodilatation and natriuresis[403-406]. The precursor compound is called pro-adrenomedullin N-terminal 20 peptide. This may be enzymatically converted to a glycine extended adrenomedullin (AM-gly) which in turn is converted to its active form by carboxy terminal amidation (mAM). The concentration of mAM is increased in congestive cardiac failure, renal failure, cirrhosis and in patients undergoing maintenance dialysis.[407-410]

Table 4.1: Atrial Natriuretic Peptides

Peptide	Source	Structure	Molecular weight (parent compound)	Active form	Other peptide fragments in circulation	Half life (active component)
ANP	Atria	126 amino acids	13.7 kDa	ANP99-126 (Carboxy terminal)	Nt-proANP1-98 Nt-proANP1-30 Nt-proANP31-67	2-3 minutes
BNP	Ventricle Atria	108 amino acids	13.3kDa	BNP32 (or) BNP77-108	Nt-proBNP1-76	15-20minutes
CNP	Vascular endothelium, uterine myometrium, placenta and testes,	Two forms CNP-53: 53 amino acids CNP-22: 22 amino acids	6 kDa (CNP -53)	? carboxy terminal peptide	unknown	similar to ANP
DNP	? atrium	38 amino acids	4.19 kDa	?whole peptide chain	unknown	similar to ANP

The synthesis of natriuretic peptides occurs in response to various distinct stimuli resulting in increased levels of gene expression, mRNA synthesis and translation to produce a signal peptide[411]. This is cleaved into a smaller fragment during transport across the endoplasmic reticulum producing the parent compound: pro-ANP or pro-BNP. The gene expression of BNP differs from that of ANP. The secretion and mRNA turnover of BNP are faster than ANP in the presence of a hypertrophic or

ischaemic stimulus[412] . This is explained by the presence of four AUUUA motifs within the 3' untranslated region of the mRNA transcript leading to a faster translation process.[413;414] The action of serine protease cleaves pro-ANP between amino acids 98 and 99 producing two equimolar fragments: ANP1-98 and ANP99-126[415]. Similar action on pro-BNP yields the two fragments BNP1-76 and BNP77-108. Slightly different processing of pro-ANP in the kidney leads to a distinct but closely identical peptide called urodilatin[416-418]. This may play an important role in the local sodium and water handling of the kidney.[419;420]

4.4 Actions:

4.4.1 Cardiovascular System:

Both ANP and BNP cause hypotension by reducing the preload. This is effected by peripheral vasodilatation and natriuresis. Vascular sympathetic tone is reduced promoting relaxation with a concomitant lowering of activation threshold of vagal afferents countering the tendency for reflex tachycardia associated with the drop in preload. Coronary vasodilatation improves perfusion without an increase in the myocardial oxygen consumption. There is also no alteration in the intrinsic inotropic state of the myocardium[421-425]. Trials with intravenous ANP infusions have shown reversal of exercise induced ST depression in patients with ischaemic heart disease[426].

4.4.2 Renal effects:

Both ANP and BNP cause natriuresis and diuresis[427]. There is afferent arteriolar dilatation with efferent arteriolar constriction resulting in increased intraglomerular pressure and filtration[428]. Mesangial cell relaxation also increases the effective membrane surface thus enhancing the filtered sodium fraction[429].

ANP and urodilatin decrease the secretion of renin from the macula densa, directly inhibit aldosterone release from the zona glomerulosa hampering the angiotensin II stimulated sodium and water reabsorption across the proximal tubular cells. [430;431] In the cortical collecting ducts ANP inhibits tubular water transport by countering the actions of vasopressin and blocks the sodium reabsorption in the medullary collecting duct.[432;433]

4.4.3 Central Nervous System:

The actions of both ANP and BNP extend beyond the blood-brain barrier and along with the locally produced peptides cause suppression of salt appetite and water intake. They also act on the brain stem decreasing the central sympathetic tone[434-436]. These actions complement their peripheral effects fine tuning their role as regulators of fluid and electrolyte homeostasis.

4.4.4. Antiproliferative effects:

CNP inhibits fibroblast activation in vitro and prevents the development of fibrosis in vivo[388;437;438]. It is now increasingly recognised that CNP forms an important endothelium derived factor regulating vascular smooth cell relaxation and inhibiting proliferation. CNP also plays an important role in endochondral ossification, is essential for testicular endocrine function and spermatogenesis and adequate placental function during pregnancy.

4.5 Mechanism of action

4.5.1 Natriuretic peptide receptors:

The actions of the natriuretic peptides are as a result of binding with specific receptors and activation of the particulate guanyl cyclase system.[439;440] There are at least seven different membrane receptors with guanyl cyclase (GC) activity synthesising the second messenger cGMP. All membrane GC receptors share a basic structure consisting of an extracellular ligand binding region, a short transmembrane region, and an intracellular protein kinase -like homology and guanyl cyclase catalytic domains. Two of these receptors named NPR-A (or GC-A) and NPR-B (or GC-B) bind with the natriuretic peptides; ANP and BNP bind with the NPR-A receptor whereas CNP binds selectively with NPR-B. The ligands for all the other receptors have not yet been identified, but it is thought that guanylin and uroguanylin bind to the GC-C receptors mediating intestinal electrolyte and water transport. Receptors localised in the retina are involved in phototransduction, the roles of similar receptors in the olfactory neuroepithelium, skeletal muscle, lung and intestine are yet to be described.[441] The signal transduction mechanism of these receptors resulting in the generation of cGMP has not been fully understood. Ligand binding to the

extracellular domain leads to a conformational change in the extracellular domain, transmembrane signal transduction causes the phosphorylation of the intracellular kinase-homology domain and activation of the bound guanyl cyclase. ATP binding to the intracellular domain seems to be essential for the enzyme activation.[442;443] The specificity of receptors for the various natriuretic peptides is shown in **table 4.2**.

Table 4.2 : Specificity of receptors for various natriuretic peptides

NPR-A	ANP>BNP>CNP
NPR-B	CNP
Clearance Receptor	ANP>CNP>BNP

4.6 Metabolism

The natriuretic peptides are inactivated by two pathways. Enzymatic degradation by Neutral Endopeptidase (NEP 24.11) and lysosomal degradation after uptake via the clearance receptor. The clearance receptors are similar to the NPR-A and B receptors but lack the intracellular guanyl cyclase domain. Animal studies have demonstrated an equal role for both receptor and enzyme mediated clearance mechanisms in the inactivation and removal of circulating natriuretic peptides.[444;445] Receptor affinity and resistance to enzymatic degradation varies, BNP binds with less affinity to the clearance receptor compared to ANP and consequently has a longer half life. Resistance to the actions of natriuretic peptides in disease states characterised by fluid overload can be partly explained by the up regulation of clearance receptors resulting in enhanced uptake and degradation associated at the same time with down regulation of NPR-A and B receptors.[446;447].

Neutral endopeptidase is a membrane bound zinc containing metallopeptidase involved in the metabolism of various peptides. In particular it is involved in the clearance of the circulating natriuretic peptides, other vasodilator peptides including substance P, bradykinin; vasoconstrictor peptides including angiotensin II and endothelin-1, and other vasoactive substances like adrenomedullin, chemotactic

peptide, enkephalins and the amyloid β peptide. NEP is widely distributed in the endothelial cells, vascular smooth muscle cells, cardiac myocytes, renal epithelial cells and fibroblasts[448;449]. NEP inhibition results in consistent increases in urine sodium and cyclic GMP excretion[450]. This is because renal tubular NEP is a major site of natriuretic peptide metabolism. Combined ACE and NEP inhibition is now being explored as a potential tool in the treatment of cardiac failure and salt sensitive hypertension[451]. The clearance receptor also plays an equal role in the degradation of the circulating natriuretic peptides.

4.7 Role of the natriuretic peptides in cardiac diseases:

4.7.1 Cardiac failure and ischaemic heart disease:

The natriuretic peptides function as a counter regulatory system to the neurohumoral activation that occurs in cardiac failure. The peptides defend against the tendency for salt and water retention and beneficially reduce the preload and filling pressures. The potent stimulus for the release seems to be the wall stretch[452;453] and shear stress produced either by the volume overload, hypertrophy or ischaemic cardiocyte damage. The degree of humoral activation that occurs in the form of enhanced catecholamine release, increased renin, excess angiotensin II and endothelin also serves as a strong stimulus for the release of these peptides.[454;455] The augmented release of ANP and BNP tend to counteract the degree of vasoconstriction produced and to some extent protect against myocyte death and replacement fibrosis. However in advanced disease, the natriuretic and diuretic responses are blunted possibly resulting from downregulation of the NPR-A and B receptors. It has also been postulated that in advanced decompensated heart failure, there is decreased renal availability of ANP, altered ANP intracellular transduction signal increased activity of neutral endopeptidase and upregulation of the clearance receptor. In vitro and in vivo studies have also demonstrated increased intracellular degradation of cGMP by phosphodiesterase.[456-458]

4.7.2 Hypertension:

The levels of BNP correlate strongly with the left ventricular muscle mass in hypertension and begin to increase further when there is associated LV fibrosis.[459-461]

4.7.3 Diagnostic and prognostic potential:

The increased levels of these peptides in various cardiac disease states are now being used as markers of disease severity and prognosis. The levels of ANP were shown to be an independent predictor of survival following MI in a multivariate analysis in a subgroup of patients in the CONSENSUS II trial[462;463]. Similar observations were made in the SAVE trial when ANP was shown to be the only neurohormone that provided independent prognostic information regarding cardiovascular mortality in a Cox proportional hazards model[464]. However when left ventricular ejection fraction was added to the multivariate models the independent prognostic ability of ANP was lost. N-terminal pro ANP is formed by the cleavage of ANP and is noted to be elevated in left ventricular dysfunction.[465-471] This was shown to be superior in predicting survival in patients after a MI in the CONSENSUS II, SAVE, and TIMI II trials. However the low specificity and positive predictive value precluded its use as a screening test for LV dysfunction. The ventricular site of production and differential gene regulation has now led to the use of BNP as an important marker of survival, left ventricular ejection fraction and ventricular modelling after a myocardial infarction[472-478]. In patients with congestive cardiac failure BNP estimations through a rapid bed side assay help in stratification of patients according to the severity of the disease[479-487]. In a recently published large scale observational study of patients presenting with dyspnoea to the emergency department, a rapid bed side evaluation of BNP accurately identified patients with cardiac failure as a cause for their dyspnoea differentiating these patients from those with respiratory problems.

4.7.4 Therapeutic potential of natriuretic peptides:

Herman et al[488] reported that injection of ANP into coronary arteries of people with normal ejection fraction and coronary anatomy was associated with a decrease in pulmonary artery pressure, left ventricular end diastolic pressure and a decrease in mean arterial pressure with dilatation of the coronary arteries with increased blood flow. Intravenous ANP has also been shown to decrease the size of

perfusion defects in patients with stable angina undergoing stress thallium testing;[489] and to promote natriuresis and diuresis in patients after a myocardial infarction without any adverse haemodynamic effects[490]. Similar effects have been observed with BNP. CNP also has been shown to reduce preload and cause vasodilatation with negligible effects on the kidney. Kalra et al have demonstrated myocardial production of CNP in heart failure which may be involved in local vasoregulation along with the other peptides[491;492]. Human recombinant BNP has now been used in over 1000 patients with heart failure in at least 10 clinical trials.[493] The food and drug administration in the United States has recently approved hBNP (Nesiritide) for the management of patients with decompensated heart failure and further trials are underway[494-500]. The results from the trials done so far suggest that Nesiritide is an effective and safe agent for improving hemodynamic profiles and symptoms of disease in patients with decompensated heart failure.

4.8 Natriuretic peptides in renal disease:

The neutral endopeptidase system is abundant in the renal tubular epithelial cells and consequently renal failure results in the loss of this degradative pathway causing an elevation in the serum levels of these peptides. Metry et al observed that the concentrations of N-terminal proANP were increased in patients with impaired renal function and this correlated with the serum creatinine.[501] Similar observations were also made by Franz et al when they measured the concentrations of ANP fragments in patients with varying degrees of renal impairment.[502;503] Urinary excretion of these peptide fragments increased with worsening renal function. Similar studies have not been done with BNP but it is conceivable that similar behaviour would be observed as the kidney also plays an important role in the degradation of this peptide.

4.8.1 Significance in the dialysis population:

The concentrations of the natriuretic peptides and cGMP are elevated in patients on dialysis. As the stimulus for release seems to be fluid overload, ANP, BNP and to a lesser extent CNP and cGMP have been extensively investigated as markers of hydration state in dialysis patients. Yamamoto et al[504;505]

noted that the concentration of ANP was increased in patients on dialysis. Rascher and Tulassay used a sensitive radioimmunoassay to measure ANP concentrations in children on renal replacement therapy. They noted that the concentrations were increased in pre-dialysis patients compared to healthy cohorts and decreased significantly post dialysis. They correlated the decrease in concentration with weight reduction on dialysis[506-508]. Eisenhauer et al measured ANP immunoreactivity in 70 haemodialysis patients and 43 controls with normal renal function. ANP concentrations were substantially elevated in the dialysis group compared to the controls and decreased after dialysis with ultrafiltration but remained elevated after isovolemic dialysis. The authors concluded that the stimulus for ANP release was fluid overload and consistent weight reduction was associated with reduction in ANP immunoreactivity levels.[509;510] Similar results have been reproduced in numerous other studies[511-516]. No consistent relationship between weight reduction or ultrafiltration volumes and fall in serum ANP concentrations post dialysis have been observed. In the majority of studies serum ANP concentrations do not decrease to levels compared to those of controls. This has been postulated to be due to patients remaining overhydrated at the end of dialysis or to their having occult cardiac disease. Talartschik et al subjected 18 haemodialysis patients to an intensive regime of ultrafiltration and observed that ANP concentrations decreased to normal at the end of dialysis in 11 patients and remained high in 7 patients. They concluded that these 7 patients had occult cardiac disease[509]. These studies confirmed the relationship between fluid overload and elevated ANP levels but fall short of demonstrating that ANP is a clinically useful tool for determining euvoemia. The high prevalence of cardiac disease in the dialysis population may partly account for the persistently elevated ANP levels as may diminished renal clearances. Dialyser clearance of the peptide fragments have been found to be variable, Saxenhofer et al[517] reported a clearance rate of 24 ± 5 ml/min whereas Deray et al[518] quoted a clearance rate of 13 ± 6.4 ml/min in their studies. Franz et al observed that dialysis with cellulose-triacetate dialysers lowered N-terminal ANP fragments more significantly than polysulfone dialysers. No differences were noted for α ANP or cGMP[519;520]. Clearances during haemodiafiltration are not known.

Earlier studies were limited by poor assay sensitivity and specificity; cross reactivity with other plasma proteins; and gross inter assay variability. The earlier immunoassays also could not reliably define

concentration ranges in normal individuals.[521-529] Furthermore it is now known that there are numerous peptide fragments of ANP in the circulation each varying biological activities[530]. ANP₉₉₋₁₂₆ (α ANP) is the C-terminal active component of pro-ANP measured by the various radioimmunoassays. The N-terminal component of pro-ANP (ANP₉₉₋₁₂₆) has also been measured in a few studies in which concentrations have remained the same throughout dialysis or even increased. In one of the biggest studies done so far Franz et al measured concentrations of α ANP, N-terminal pro-ANP, ANP₁₋₃₀, and ANP₃₁₋₆₇ in 122 haemodialysis patients before and after dialysis.[531] The authors noted that the concentrations of all these peptides were markedly increased compared to normal cohorts and that dialysis reduced the concentrations of α ANP more significantly than the other peptides. Again there was no correlation between ultrafiltration volumes and reduction in α ANP concentrations. In addition the concentrations of all these peptides were increased in a subgroup of patients with cardiac disease and decreased to a lesser extent post dialysis compared in these patients than in those without cardiac disease. With the advent in the last 5 years of non-competitive assay techniques like two site IRMA, ELISA and immunoluminometry; measurement of these peptide fragments has become reliable.[532-534]

Though ANP remains the extensively investigated natriuretic peptide in the dialysis population, BNP and to a lesser extent CNP and cGMP have also been evaluated in numerous studies as markers of the hydration state. Franz et al measured cGMP concentrations in 122 haemodialysis patients and noted that the concentrations were elevated pre-dialysis falling significantly post-dialysis. In patients where the concentrations remained high post-dialysis; there was no convincing evidence of fluid overload[535]. There was no relationship between cGMP levels and inferior vena caval diameter (IVCd) which was used as a surrogate marker of fluid overload. Metry et al measured cGMP, ANP and N-terminal pro-ANP in 12 haemodialysis, 17 pre-dialysis and 18 healthy volunteers along with inferior vena caval diameter (IVCe) and found no correlation between ultrafiltration volumes and the natriuretic hormone levels[536]. BNP appears even less sensitive to fluid volume changes than ANP and cGMP but correlates better with the degree of cardiac dysfunction Fagugli et al investigated the relationship between hydration state as measured by bio impedance and serum BNP concentrations pre-dialysis in 32 haemodialysis patients with no overt cardiac disease. There was a statistically significant relationship between hydration state and

serum BNP levels. Patients with the highest BNP levels had a greater extracellular fluid volume compared to patients with the lowest BNP concentrations. The group with the highest BNP had higher pulse pressures and LV Mass index[537;538]. Lee et al in a similar study noted that the pre dialysis BNP levels correlated with pulse pressure and ECF/TBW ratio (bio impedance). They concluded that BNP had a limited role in the assessment of hydration state in dialysis patients.[539]

Numerous studies have evaluated the role of ANP and BNP as markers of cardiac dysfunction. Mallamaci et al measured α ANP and BNP (BNP₇₇₋₁₀₈) in 246 haemodialysis patients with no clinical evidence of heart failure and found that ANP and BNP independently related to left ventricular mass and ejection fraction;[540;541] BNP was more sensitive than ANP in diagnosing left ventricular hypertrophy and had a high negative predictive value. Similar observations have been made by other investigators in dialysis patients. Goto et al [542] and Naganuma et al [543] have independently evaluated the prognostic value of elevated BNP levels in dialysis patients without overt cardiac disease. They found that more cardiac events occurred in patients with the highest BNP levels during follow up. Cataliotti et al investigated the relationship between elevated natriuretic peptide levels and cardiac function in 112 dialysis patients. Concentrations of all the peptides were increased when compared to normal cohorts. ANP and BNP levels correlated significantly with left ventricular mass index whereas CNP and DNP did not. The left ventricular ejection fraction (LVEF) strongly inversely correlated with ANP and BNP concentrations, weakly significantly correlated with DNP levels and did not correlate with CNP concentration. [544]

Natriuretic peptides have also been evaluated as markers of the fluid state in CAPD patients with results similar to those in haemodialysis patients.[545-551] Nakatani and others reported significant relationships between BNP and cardiac function as observed in the haemodialysis cohorts.[552] ANP concentrations related to the degree of fluid overload but were not significantly lower after fluid removal. Totsune et al found that CNP, ANP and BNP were significantly increased in patients with renal failure and those on dialysis[553]. In patients with congestive cardiac failure the concentrations of CNP were not elevated in contrast to the greatly increased concentrations of ANP and BNP. More recently the newly discovered hypotensive peptide adrenomedullin has been evaluated as a marker of fluid overload. Its behaviour on dialysis closely mirrors that of ANP[554-558].

All the studies consistently establish the fact that the concentrations of ANP and to a lesser extent BNP are significantly elevated in the dialysis population, but the overall effect of dialysis seems to be that of reduction in concentrations rather than normalisation. It is conceivable that the close relationship between BNP and baseline cardiac function will confound its role as a marker of the hydration state as borne out by the results of the studies mentioned above. The same analogy can be drawn albeit to a lesser extent for ANP but the rapid release in situations of acute fluid overload makes it a better marker of the volume state. The situation in the dialysis population is different in the sense that the fluid overload occurs over a longer period of time (inter dialytic interval); fluid removal is often not accurate enough to achieve euvolemia and there is a high incidence of cardiac disease. Furthermore the different dialysers used, the flux of dialysis, unknown effect of high efficiency treatments like haemodiafiltration, variability of the assays and the low molecular weights of the active peptide component of the parent compound make interpretations fraught with ambiguities. Also, not much is known about synthetic rates of these peptides, their clearances in the absence of renal function, thresholds for release in the presence of constant changes in the fluid state and whether fluid removal produces as strong a stimulus for switching off synthesis as does acute increase in volume.

Table 4.3. Natriuretic peptides in dialysis patients

Authors	Parameters studied	Patient group	conclusions
Kohse et al	ANP, BNP, cGMP	49 HD	ANP, BNP, cGMP ↑ pre-dialysis; ANP ↓ more significantly than BNP
Corboy et al	ANP, BNP, Left and Right atrial & left ventricular volumes	8 HD	ANP and BNP ↑ pre-dialysis; significantly ↓ by UF, changes in ANP correlated with changes in left atrial volume; BNP did not
Haug et al	ANP & BNP	30 HD 30 coronary artery disease	↓ ANP > BNP post-dialysis; ↑ LVEDP caused significant ↑ in both BNP & ANP
Takahashi et al	ANP, BNP, CNP, cGMP Cardiothoracic ratio by CXR	HD; no DM	all peptides ↓ after dialysis; cardiothoracic ratio on CXR pre-dialysis correlated with ANP/BNP; systolic BP correlated with CNP; ΔBW correlated with ANP
Ishikura et al	ANP BNP; 2D Echo	15 HD	↓ in ANP post-dialysis; BNP correlated with fractional shortening pre- & post-dialysis;
Franz et	cGMP pre- & post-dialysis	125 HD	dialysis ↓ cGMP; ↑ post-dialysis cGMP not hypervolemic; mean cGMP

al ⁴⁹⁷			↑ in overhydrated patients without CAD
Katzarski et al	ANP,renin,AVP, catecholamines,aldosterone, I ¹³¹ labelled Albumin for volume	16 HD	ANP ↓ post dialysis;↓ in ANP correlated with UF rate
Franz et al ⁴⁹⁸	N-terminal ANP fragments, cGMP, ANP ⁹⁹⁻¹²⁶	122 HD	all fragments ↑ pre-dialysis; significant ↓ post dialysis; no correlation with UF volumes; cardiac disease ↑ both ANP ⁹⁹⁻¹²⁶ and ANP fragments; hypertensive patients had ↑ concentrations of both peptides;
Mallamaci et al	ANP,BNP	246 HD, no CCF	ANP & BNP independently related to LV Mass and EF; BNP better marker of LVH
Osajima et al	ANP,BNP,cGMP	39, 2 groups, HD with and without CAD,	in the CAD group all peptides ↑ pre-dialysis; significant ↓ post-dialysis but not to normal; post dialysis levels ↑ than those without CAD; no correlations between peptide levels ΔBW; levels ↑ in group without CAD when compared to the normal population; BNP correlated with severity of CAD
Nishikimi et al	ANP/BNP	76, HD	ANP levels ↑ pre-dialysis, dialysis ↓ ANP levels, BNP levels variably ↓ by dialysis, both ANP & BNP ↑↑ in presence of CAD; BNP sensitive marker of LV dysfunction in CAD group.
Zoccali et al	ANP/BNP	246, HD, no CCF	ANP/BNP correlated with LVMI; BNP independent predictor of death in a Cox's model including LVM and EF
Metry et al	ANP/N-terminalANP/cGMP	12 HD, 17 CRF; 18 Controls	serum cretinine correlated with N-terminalANP in the CRF group; IVC diameter correlated with NterminalANP , ANP and cGMP pre-dialysis; IVC diameter post dialysis correlated with ANP and cGMP;
Cataliotti et al	ANP/BNP/CNP/DNP	112, HD, no CCF	ANP/BNP correlated with LVMI and inversely correlated with EF; CNP/DNP no correlation with LVMI; patients with LVH had higher ANP/BNP; BNP ↑ in patients dying due to CAD, BNP important biomarker of LVH in dialysis population
Goto et al	ANP/BNP	53 HD, no clinical CAD	cardiac events (13 patients) in patients with highest ANP/BNP levels; elevated peptide levels predict future cardiac events
Naganuma et al	BNP	164 HD, 14 controls	13 deaths due to cardiac events in 36 months, highest BNP in patients who died, BNP concentrations ↓ by dialysis, good correlation between ↑ BNP and LV dysfunction

4.8.2 Therapeutic value of natriuretic peptides in Acute Renal Failure:

The Anaratide Acute Renal Failure Study Group[559] randomized 222 patients with oliguric acute renal failure to receive either a 24 hour infusion of ANP (Anaratide) or placebo. The primary efficacy end point was dialysis free survival through day 21. Although there was a trend towards improved dialysis- free survival in the ANP treated group, this was not statistically significant. In a separate study involving 504 patients with acute tubular necrosis ANP decreased the need for dialysis only in oliguric patients[560]. Various other case reports have suggested elective administration of Urodilatin decreased the incidence

of post-operative acute tubular necrosis in patients undergoing cardiothoracic surgery and liver transplantation.[561-563]

4.9 Summary

In conclusion, the natriuretic peptides are important counter regulatory hormones serving as the humoral link between the heart and kidneys. They play an important role in fluid volume homeostasis and counter the neuroendocrine activation occurring in heart failure. The concentrations of these hormones are increased in various disease states characterised by fluid overload. ANP and BNP concentrations correlate well with the presence or absence of left ventricular dysfunction. BNP concentrations help in risk stratification of patients with decompensated heart failure and serves as an important prognostic tool. CNP is an important endothelium derived vascular relaxation factor which also has antimitogenic and antiproliferative effects. The newer peptides, DNP and adrenomedullin have actions broadly similar to ANP. The increased concentrations of ANP and BNP in the dialysis population have led to an extensive research into their potential roles as biochemical markers of the prevalent volume state. The association between fall in ANP concentrations and fluid removal on dialysis is not robust enough to use ANP as a marker of approaching euolemia. Further research needs to be done to elucidate ANP kinetics in the dialysis population with particular reference to the stimuli for secretion; role of the dialysis process itself; nature of enzyme rebound if any at the end of dialysis; receptor density in states of alternating dryness and fluid overload and the role of the degradative pathways when intrinsic renal clearances are very much reduced. Also ligand – receptor interactions are still poorly understood even in normal physiological conditions with even poorer understanding of the mechanisms involved in disease states. On the plus side however, these peptides, in particular BNP, are increasingly being used as screening tools in asymptomatic subjects and could play an important role in early identification of cardiac disease burden in the dialysis population. On the therapeutic side recombinant BNP is now being used in refractory heart failure and further studies are underway exploring the possibility of intermittent dosing based in an out patient clinic. Adrenomedullin and DNP remain novel peptides whose roles in normal and disease states is not yet fully understood.

Chapter 5

Materials and Methods

5.1 Introduction

This chapter describes the study population and the criteria defined for the inclusion into various studies. The techniques used and evaluated for their usefulness as fluid management tools have been discussed. All studies were carried out after gaining ethical approval from the East and North Hertfordshire Ethics Committee and were registered with the Clinical Audit and Research Department of the East and North Hertfordshire NHS Trust.

Written consent was obtained from all participants. General Practitioners were informed of their participation.

5.2 Techniques: General

5.2.1 Study Population:

The subjects were recruited from the haemodialysis cohort dialysing in the renal unit at the Lister Hospital. The renal unit provides dialysis services to the population of Hertfordshire and Bedfordshire, numbering 1.13 million. The dialysis services are provided from the main unit at the Lister Hospital site and the satellite units at the Luton and Dunstable Hospital and St Albans City Hospital. At the time the studies were being performed around three hundred and sixty patients were undergoing haemodialysis thrice weekly in these units. These prevalent patients had a median age of 65.4 years. Patients were predominantly white (71%); the proportion of Asian and Black patients were 11.7 and 6.2% respectively. The median vintage of the prevalent patients was 2.3 years. Diabetes, primary glomerulonephritis, hypertension, polycystic kidney disease, renovascular disease and reflux nephropathy were the common causes for ESRD in this population. In 15 % of the patients the aetiology of renal failure was not known.

The criteria of eligibility for participation into the studies described subsequently are as follows

- Working permanent access (AV Fistula) or tunnelled haemodialysis catheter (TVC) with flows >250ml/min
- Not on more than two antihypertensive agents

- No significant LV dysfunction; ejection fraction > 50%; no clinical evidence of cardiac disease
- Haemoglobin > 10 g/dL and a serum Albumin >30g/L
- Clinically assessed and defined dry weight (prevailing dry weight ascertained to be accurate during a clinic attendance not longer than 3 months prior to the study)
- Haemodynamically stable with blood pressure stability on >90% dialysis sessions (haemodynamic stability defined as <20mm Hg drop in MAP in response to UF, SBP >90mm Hg throughout, no symptoms of intra-dialytic hypotension- such as dizziness, cramps, or headache)
- Have no history of previous lower limb DVT, peripheral vascular disease or indurated leg oedema

In addition, none of the study patients had pacemakers or implanted cardiac defibrillators. All patients dialyzing through a fistula <65 years of age received post-dilutional heamodiafiltration (HDF) with none of these patients having a high output fistula (fistula blood flows and recirculation data repeated every 6 months using a Transonic HD01 monitor). Patients were not allowed to eat or drink during dialysis. All patients were reviewed by the Renal Dieticians every 6 months. Advice on salt restriction was given as part of this review. Bioimpedance data was collected over two dialysis sessions in the pilot refill ratio study and in the vascular refill-blood temperature monitor study. In these instances the two dialysis sessions studied were the same day of the week.

In all, a total of 81 patients participated in all the bioimpedance related studies. Of these, 18 patients were not on HDF. During bioimpedance studies where the UF was prescribed in pulses HDF was not carried out. This is because, HDF delivery requires a UF profile to be set at the start of the dialysis session with no alterations allowed apart from stopping UF during the session.

As part of the natriuretic peptide studies, 31 patients were studied, all of whom were on HDF during their routine dialysis sessions.

5.2.2 Renal Plus

The data management system used at the Renal Unit is called Renal Plus® (Chi Plc, UK).

It is built on the Microsoft SQL Server platform with a customised Microsoft Access programme running the front-end of the server. This database encompasses all aspects of renal patient management at all levels (clinicians, nurses, medical secretaries, IT support professionals). Modules have been designed for outpatient and inpatient activities. RRT patients are categorised by their modality and data input options vary as appropriate. In terms of haemodialysis, all sessions are logged with clinical observations pre- and post-HD, intra-dialytic symptoms and access performance. The software schedules and calculates monthly monitoring of Urea Kinetic Modelling based assessments of haemodialysis adequacy. Abnormal results are highlighted through system flags and allow experienced professionals to reschedule tests and re-run adequacies. Data downloads are automatic from the hospital pathology server with 6 hourly daily updates of blood test results.

Data can be retrieved on all patients dating back to 1990. In addition the database offers powerful search features for data retrieval based on user requested criteria for research and audit purposes. The programme was developed in-house at the Lister Hospital and has now been implemented in other Trusts across the UK.

5.2.3 Laboratory variables:

Where specified, blood samples were drawn for routine measurement of blood urea, serum creatinine, sodium, potassium, bicarbonate and full blood count (FBC). Measurements were carried out in the clinical biochemistry and haematology departments of Lister Hospital and for satellite unit patients at the Luton and Dunstable Hospital. Assays were carried out by standard autoanalyser methods. Serum sodium was measured by Flame Atomic Emission Spectroscopic method (FAES).

5.2.4 Dialysis:

All patients underwent high flux haemodialysis thrice weekly using bicarbonate buffer, 1.8-2.2 m² hollow fibre polysulfone membranes (Fresenius FX 80/100; Arylane H9), blood flow rates of 250-500mL/min and dialysate flow rates of 800ml/min, using Fresenius 4008H delivery system with a built in ultrasonic blood volume monitor. Dialysis was individualised and prescribed according to a two-pool urea kinetic model with a target Kt/V of 1.2. Dialysis fluid contained sodium (138mmol/L); potassium (2 mmol/L); calcium (1.25mmol/L); magnesium (0.5mmol/L); chloride (108.5mmol/L); bicarbonate (35mmol/L) and glucose (5.5mmol/L). Dialysis fluid composition in the past at the Lister Renal Unit had been slightly different with calcium and magnesium concentrations being 1.75mmol/L and 0.25mmol/L respectively.

The temperature was maintained at 36°C (except during the BTM study when it will be controlled by the module to prevent rise in core temperature, isothermic). BTM[®] and BVM[®] modules were built into the 4008H system and were calibrated as per the manufacturer's instructions.

Briefly, the BVM module (described below) was calibrated during the priming process by the passage of saline with the dialysate temperature set at 36°C. Once calibrated, blood was allowed to enter the circuit. A similar procedure was recommended for the BTM.

Blood pressure (BP) readings were obtained through the built in Fresenius BP module. Dinamap PRO series BP monitor (Wipro GE Healthcare, UK) was used in instances where the built in module was unavailable (not all 4008H had all 3 modules). This has been validated in a previous study carried out in the unit evaluating BP profiles in the renal unit and their correlation with ABPM (Mitra *et al* [203])

5.2.5 Data Acquisition set up: Finesse

Both the bioimpedance and dialysis data were time stamped and synchronised with each other. The data from the Fresenius dialysis delivery system (4008H) was retrieved through a custom built data capture system implementing the Finesse[®] database management (FinDB, IsyMed, Germany) software licensed by Fresenius UK for use in their machines.

The FinDB is widely used as a solution for networking all dialysis machines in a unit integrating all aspects of patient care from the point of entry to the unit until the completion of dialysis. Individual

patient demographic data are stored in keys retained by the patient. Insertion of the key prior to having weight and BP measurement into compatible machines registers a dialysis session and data stream from these devices is then integrated with the data stream from the Fresenius dialysis delivery system after patient inserts the key into the machine. Data streams are transported through the network to a central server where they are stored and can be retrieved by the end-user/clinician. Variables measured include pre-,post-haemodialysis and intradialytic blood pressure (BP); Relative blood volume (RBV) and Blood Temperature Monitor (BTM) parameters; dialysate conductivity, ultrafiltration (UF) volume, blood flow (Q_b) and dialysate flow rates (Q_d). Urea kinetic modelling (UKM) and ionic mass balance (IMB) transfer can also be performed remotely and archived per session if required. In addition, blood test results can also be downloaded directly into the server from compatible analysers.

The Renal Unit at Lister and its satellite units do not have a central implementation of the FinDB system. Instead a portable system was implemented using FinDB running from a laptop acting as a server. The 4008H system communicated to the laptop through a bedside link (BSL2001) that could accept a programmed key. The key was programmed by accessing the Access database of all HD patients (created for the research purpose) and then inserted into the BSL.

Dialysis data was then streamed to the laptop with user options to add to the data stream parameters such as BP and weight pre- and post-HD. A discrete data packet was generated every 15 seconds containing dialysate, blood, and UF flow rates; RBV change and thermal variables with the BTM. At the end of dialysis, a log was created on the laptop registering the dialysis and a text file listing all data was saved in a designated folder. The text data was then extracted by an Excel file specifically created for this purpose. The setup used is illustrated in Figure below.

The advantage of the system was the frequency of data generated pertaining to the dialysis and the ease of its collection across the different units. To the researcher's knowledge, this remains the only way of reliably collecting data relating to dialysis when expensive pan-unit implementation is not possible.

The schema of data collection and components is illustrated in **Figure 5.1**

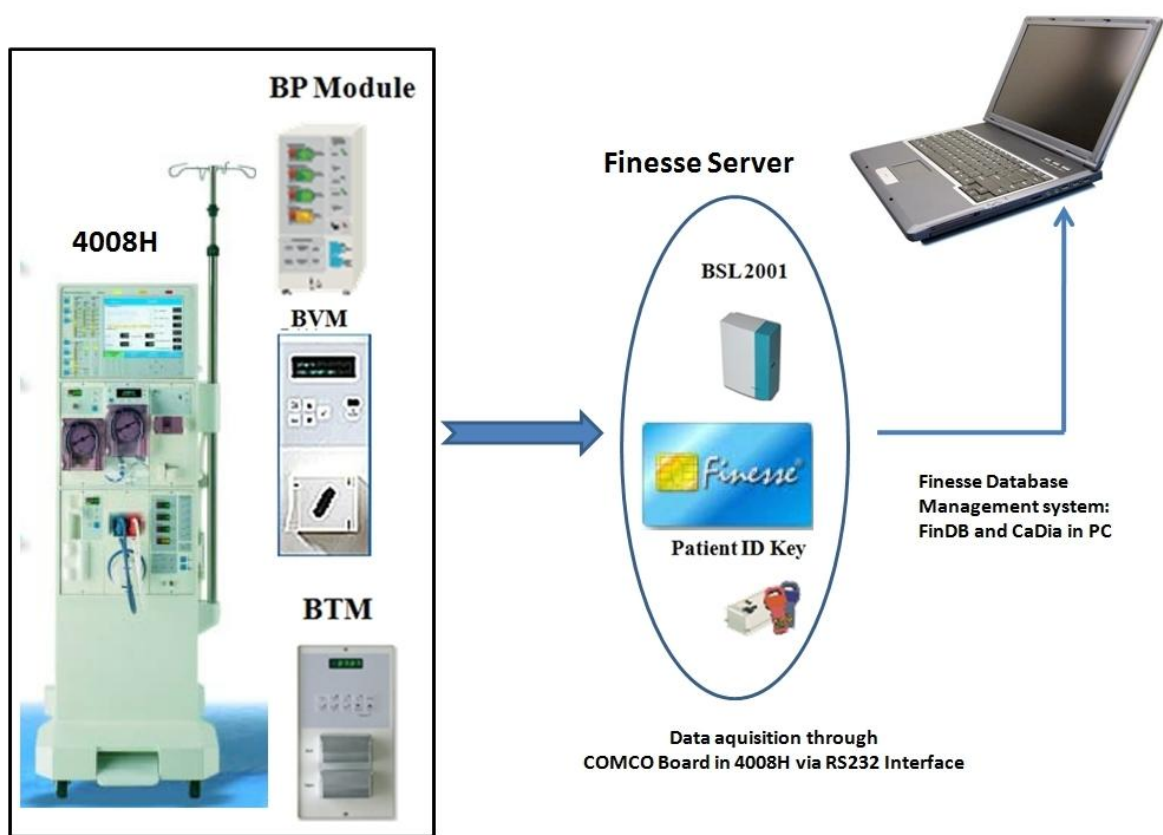

Figure 5.1: Finesse Data Acquisition system

5.3 Techniques: Specific

5.3.1 Blood Volume Monitoring:

Blood volume monitoring was performed using a real-time online ultrasonic blood volume monitor (Fresenius BVM), which measured the velocity of sound across flowing blood using a cuvette in the extra extracorporeal circuit. The variability of the velocity of sound in this system depended on changes in the density of total protein content (sum of plasma proteins and hemoglobin). Relative blood volume (RBV) at any given time may be determined from changes in protein concentration relative to the initial starting value. A high precision temperature measurement compensates for the dependence of sound velocity on blood temperature. The method has been validated as a precise and reliable measurement of RBV and has a very low noise signal ratio ($<0.2\%$) and a sampling rate as low as 3 seconds. The technique has

been compared against standard reference methods involving serial measurements of hemoglobin (photometric cyanomethemoglobin [$r > 0.96$; SD, 1.7%]) and microcentrifuge hematocrit.

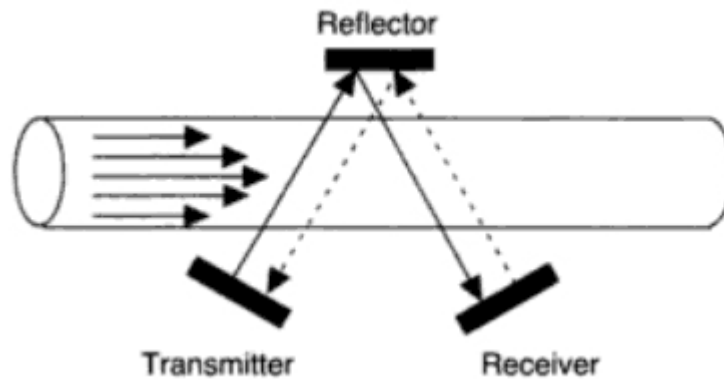

Figure 5.2 Ultrasonic volume flow sensor: using wide beam illumination two transducers pass ultrasonic signals back and forth alternately intersecting the flowing blood both in upstream and downstream directions. Difference in signal intensity provides information on blood flow, average signal intensity the composition of blood.



Technical Data / Accuracy	
Relative Blood Volume (RBV)	1.7 % (absolute)
Haematocrit (Hct)	± 2.9 Hct %*
Haemoglobin (Hb)	± 0.8 g/dl
Temperature	0.1 °C (33.5 – 40°)

* if plasma protein concentration range is 60-85 g/l

Fresenius 4008 BVM Module and sensor head

(reproduced with permission from Fresenius AG, Germany)

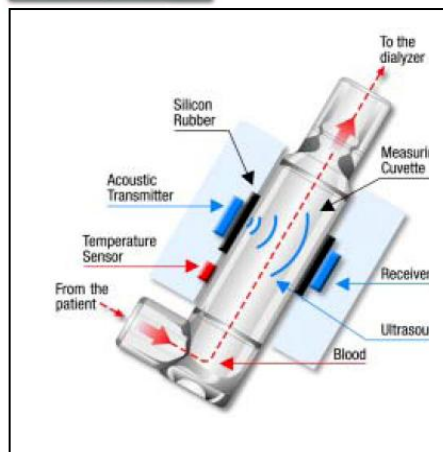

Figure 5.3 Components of Fresenius 4008 Blood Volume monitor Module

5.3.2 Blood Temperature Monitor

The Blood Temperature Monitor performed active control of blood temperature in the extra corporeal circuit and eventually of the patient. The device had two sensors, which non-invasively monitored arterial and venous blood temperature in the extra corporeal circulation. On the basis of these recordings the corresponding fistula temperatures were calculated. Arterial blood temperature was determined by the body temperature, and venous temperature by the temperature of the dialysate. By altering the temperature of the dialysate, the temperature of the venous blood entering the fistula can be altered resulting in net heat loss or heat gain in the patient. In order to maintain a constant core temperature, the BTM continuously measured the temperature of the blood in the arterial and venous sensor heads and calculated the corresponding fistula temperatures, taking into account the thermal losses in the blood tubing system. Through thermodilution techniques the cardiopulmonary recirculation was calculated from which the body core temperature was derived, taking into account other system parameters including ambient temperature, blood flow rate, thermal conductivity of the tubing and the distance between the patient and the sensor. Once a target core temperature was set, this was maintained by varying the dialysate temperature. This mode of operation is the ‘T’ control mode with the BTM. Various thermal data can be displayed while the BTM is operational. These include the arterial fistula temperature, venous fistula temperature, thermal energy flow rate (kJ/h), and total thermal energy balance in kJ. The BTM regulated the temperature of the dialysate within a narrow physiological range (35-38°C) This avoided the risk of undercooled or overheated blood being returned to the patient. BTM monitored arterial and venous limb temperatures, and also measured the thermal energy flow (kJ/h) and the total energy change during dialysis. (negative value indicates energy removal through the extracorporeal circuit).

The heat flow in extracorporeal circulation (H_{ec}) during dialysis is given by:

$$(H_{ec}) = -c_Q T_{art} Q_b + c_Q T_{ven} (Q_b - UFR)$$

where Q_b is the blood pump speed, T_{art} and T_{ven} are the arterial and venous limb temperatures measured at the sensor heads of the BTM. The constant c_Q represents the product of specific heat capacity c and

density ρ of the human body. Rearranging the above equation gives the total energy flow in the extracorporeal circulation:

$$H_{ec} = -c \rho \{(T_{art} - T_{ven})Q_b - c\rho (T_{art} - T_{ven})UFR\}$$

In constant temperature dialysis there is a net change in the thermal capacity of the extracorporeal system which either results in rise or fall of the core temperature.

In isothermic dialysis (**T-control mode**) however there is thermal energy removal in extracorporeal circuit to maintain a constant core temperature. BTM uses these algorithms to calculate heat flow rates and the total heat change during dialysis.

In thermoneutral mode (**E-control**) energy flow in the extracorporeal circuit can be set to zero by varying the dialysate temperature so that no energy is removed from or added to the patient. This results in the rise of core temperature.

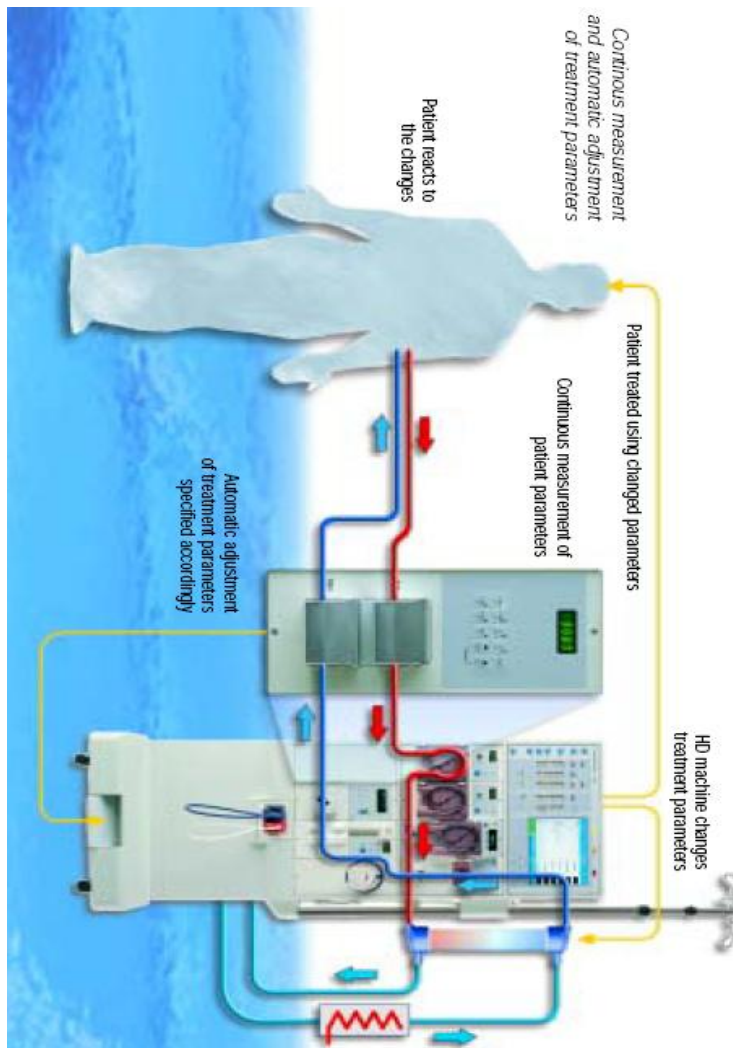

Schema for thermal regulation using the Fresenius BTM 4008

(Reproduced with permission from Fresenius AG, Germany)

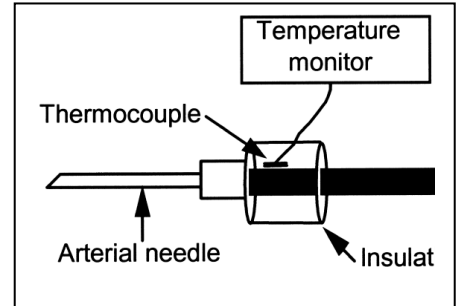

Figure 5.4 Blood Temperature Module: Fresenius

5.3.3 Bio impedance Spectroscopy

Xitron 4200 (Xitron-Tech, San Diego, California, US)

Segmental and whole body bioimpedance measurements were carried out using the Xitron 4200. The device uses the Cole model to derive the resistance values and has the software algorithm built-in to calculate the respective fluid volumes. These principles have been described elsewhere. The device uses small amplitude current between frequency ranges of 5kHz and 1 MHz and plots the resistance and reactance values to obtain the impedance at these frequencies as discussed previously. The amplitude of current used is between $50\mu\text{A}$ and $750\mu\text{A}$. The device can interface with a personal computer through a

RS232 connection and can be used thus to record data continuously. The device has a utilities software suite to manipulate raw data to derive R_{ECF} & R_{ICF} values and also plot the data in real time.

The device has a set of 4 patient cables (2 pairs); one pair called the injection leads and the other the voltage leads. The electrodes attach to skin via sticky gel electrodes with a surface area of at least 5cm². The device can be manipulated via the software interface to measure Whole Body Bioimpedance (WBIS) or Segmental Bioimpedance Analysis (SBIS). The investigator underwent training at the Renal Research Institute (RRI) in New York in the technique of continuous bioimpedance analysis. The RRI has done pioneering work in the technique of segmental bioimpedance and has published results in both peritoneal and haemodialysis patients over the last seven years. The continuous segmental technique has been tested on both normal volunteers and the dialysis population. The hardware used by this investigator was not modified in any way. The data output from the Xitron consists of three text files labelled in a proprietary way by the manufacturer to reflect raw impedance data (.DAT extension), modelled for R_{ECF} and R_{ICF} (.MOD extension) and volume derived (.VOL extension). All these files can be opened in a notepad application and exported into Microsoft Excel®. The .DAT file enumerates the frequency tested, impedance obtained, the phase angle, invariant time delay (T_d) and characteristic frequency (f_c). A separate modelling software is also provided if the operator wishes to model raw data with any specific changes to the resistivities quoted by the manufacturer. The investigator used data modelled by the Xitron without any post-capture modification.

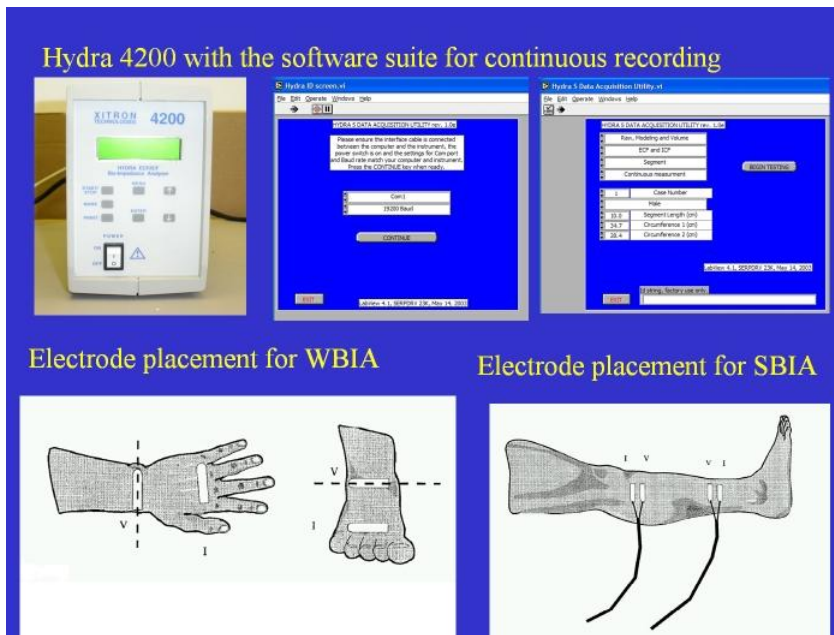

Figure 5.5 : Xitron 4200 analyser, software suite and electrode placements

5.3.3.1 Equations involved in the calculation of fluid volumes specific to the Xitron device:

The Cole model is used to obtain R_{ECF} and R_{ICF} . The extracellular and the total body water is calculated by the following equations, using Hanai's mixture theory.

The extracellular fluid volume is given by the following formula:

$$V_{ECW} = k_{ECW} \left(\frac{L^2 \sqrt{Wt}}{R_E} \right)^{2/3} \quad \text{where} \quad k_{ECW} = \frac{1}{1,000} \left(\frac{K_B^2 \rho_{ECW}^2}{D_b} \right)^{1/3}$$

L: height of subject

Wt: weight of subject

R_E : extracellular fluid resistance as measured by the Xitron

ρ_{ECW} : extracellular water conductivity

D_b : Density of the body

K_B : Anthropometric constant to correct for the geometry of human body during whole body bioimpedance analysis

Further derivation using the Hanai's mixture theory gives the following for estimation of intracellular volume

$$\left(1 + \frac{V_{ICW}}{V_{ECW}}\right)^{5/2} = \left(\frac{R_E + R_I}{R_I}\right) \left(1 + \frac{K_p V_{ICW}}{V_{ECW}}\right)$$

R_I : ICF resistance from Xitron

k_p : constant: ratio of intracellular and extracellular water conductivity.

Total body water is derived as

$$V_{ECW} + V_{ICW}$$

5.3.3.1.1 Equations for calculation of segmental volumes:

$$ECV_s = k_s \rho_{ECV} \frac{L_s^2}{R_s}$$

ECV_s : extracellular fluid volume of segment 's'

k_s : Anthropometric constant correcting for body geometry, $k_s = 1$ for arms and legs; $k_s = 4$ for trunk

ρ_{ECV} : segment resistivity; constant; (47 Ω .cm)

R_s : measured extracellular fluid resistance of segment

L : length of segment

The sum of segmental volumes gives the total body ECF volume and Total Body Water.

$$ECV_{SS} = 2(ECV_{arm} + ECV_{leg}) + ECV_{trunk}$$

The equations described above were adapted from Mathie and De Lorenzo's work described in a previous chapter.[327;564;565] The manufacturers did not disclose the modifications they had made to the original equation of Mathie *et al.* The proprietary Xitron equation was developed in-house at Xitron-Tech (San Diego, CA, USA) and was not discussed in the manufacturer literature. However the modifications were made to improve the accuracy of the ICF measurement that did not have any bearing on the studies done for this thesis.

As trends in ECF were studied, the investigator did not make any modifications to the ECF resistivity. (This had been suggested by Zhu *et al* when measuring TBW and ECF from the SBIS method)

5.3.4 Natriuretic peptides

5.3.4.1 ANP:

Alpha Atrial Natriuretic Peptide (α ANP) was measured by a radioimmunoassay. A rapid vacuum driven procedure, using pre-treated Sep-Pack C18 cartridges, was used to extract ANP from the plasma. Non-specific interference was removed by fractional elution with an aqueous methanol/trifluoroacetic acid (TFA) mixture. ANP was then coeluted under positive pressure with a methanol/TFA mixture and the eluates air-dried before measurement using radioimmunoassay. The radioimmunoassay has been validated for use in various reference populations both normal and otherwise.

Blood samples were taken in chilled EDTA tubes, centrifuged at 5°C, plasma separated and stored at –70° C.

The assay was carried out at the Department of Clinical Biochemistry, Royal Gwent Hospital, Newport. The concentrations across different age groups varied between 15-40pg/ml (95% CI). The Department of Clinical Biochemistry has been using the assay since 1992 and have published results in various populations.[566] The extraction process and the assay elements are standardised for the measurement of the α ANP fraction (carboxy-terminal, ANP₉₉₋₁₂₆) of the intact peptide that is wholly intravascular with a half life of 2-3 minutes.

5.3.4.2 BNP:

BNP₇₇₋₁₀₈ (carboxy terminal peptide or BNP32) was measured using a Triage BNP Assay kit (Biomed Diagnostics incorporated, San Diego, CA). This is the only available point of care bed side kit to measure BNP[567-569]. The assay has been available since 2001 and its accuracy has been validated against radioimmunoassays available commercially[570]. More than 2000 patients with congestive cardiac failure have been studied and their prognosis stratified based on Triage BNP assay results.

This kit uses an immunofluorescent assay to determine concentrations using a 0.5ml EDTA blood sample with normal range <100pg/ml. The upper limit of the detection range was 2000 pg/ml. The sample was introduced into a test strip that aspirates the blood by capillary action into a chamber with the reagents and then read by a dedicated Triage meter (degree of fluorescence). Samples could also be centrifuged and plasma stored at -20 °C for later analysis after thawing for 15 minutes.

5.4 Statistical analysis

Microsoft Excel® (Microsoft Corp, USA) was used to synchronise CSBIS data with RBV/BTM data obtained from FinDB on a single time line. Further manipulation of R_{ECF}-RBV data was done using Excel to generate trends over time.

Basic demographic data was collected on all patients that included age, gender, dialysis vintage, dialysis time, UF volumes, blood pump speed (Q_b), systolic blood pressure (SBP), diastolic blood pressure (DBP) and mean arterial pressure (MAP) (in relevant studies) and were inputted into SPSS statistical software v12 (SPSS Inc, USA). Data from specific studies (retrospective dry weight study, ANP studies, Sodium balance study) were analysed using SPSS software.

For normally distributed data descriptive statistics included calculation of mean and standard deviation. Student 't' test was used to assess significant differences between means. Linear regression analysis was employed to explore relationships between variables with calculation of the Pearson coefficient. For non-normally distributed data non-parametric methods (Wilcoxon, sign rank tests) were used in appropriate situations. Alternatively the data was log-transformed prior to the application of parametric methods. The

Chi-squared test with Yates' was used to determine the significance of differences in proportions between groups.

One way ANOVA was used to compare slope changes during specific interventions in the 'Factors influencing CSBIS' study. Prism v5 (Graphpad, USA) was used for these analyses

Curve fitting to generate coefficients of first order decay was carried out in the 'Factors influencing CSBIS' study using Prism v5 (Graphpad, USA).

A 'p' value <0.05 was taken to be significant in all of these studies.

CHAPTER 6.1

Dissociation between changes in blood pressure and dry weight after initiation of incremental high-flux haemodialysis

6.1.1 Introduction

This study was carried out to identify the trends in weight and their relationship to changes in blood pressure during “probing for dry weight” in the initial weeks after dialysis initiation. Most patients with advanced kidney failure are volume overloaded. One of the major aims of renal replacement therapy is to rectify this imbalance in volume, and thereafter maintain euvolaemia. Short duration large volume ultrafiltration therapies, are often associated with significant stress on the cardiovascular system as a consequence on rapid rates of fluid removal. This often leads to chronic volume excess since the last vestige of the excess fluid is difficult to remove in the shorter sessions.

Dry weight is defined as the the lowest weight a patient can tolerate without intradialytic symptoms and/or hypotension and in the absence of overt fluid overload. [571] There is as yet no adequacy measure for optimal fluid removal during dialysis. An imprecise dry weight estimation often leads to deleterious consequences that impact on long term survival and quality of life in dialysis patients. Eighty percent of all hypertension in the dialysis population is related to chronic hypervolemia.[572].

Charra et al have achieved normotension in their patients through a combination of dietary restriction and long hour dialysis.[83;573;574]. They have described changes in weight, blood pressure and use of antihypertensive agents during the first year after dialysis initiation (Figure 6.1) They have also observed a lag period between the decrease in weight and normalisation of the blood pressure [575].

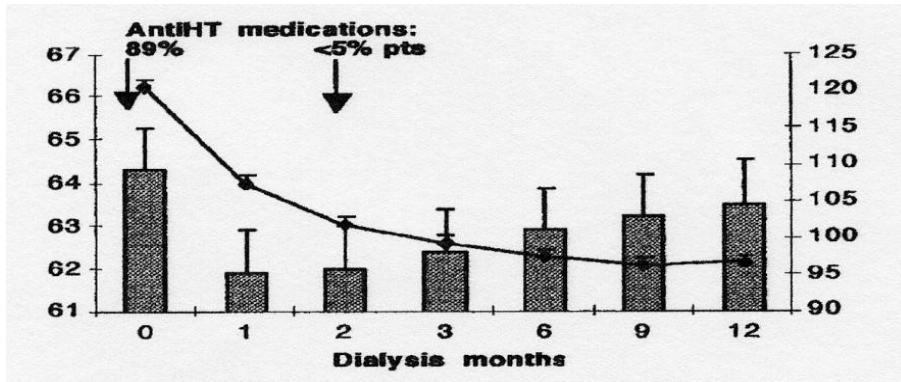

Figure 6.1.1. Weight and blood pressure changes during the first year after dialysis initiation. The Tassin experience (Charra, Bergstrom and Scribner. Am J Kidney Dis 32, 720-4, 1998)

Volume overload and hypertension are responsible for the increased cardiovascular and cerebrovascular morbidity and mortality in the dialysis population.[576] Left ventricular dysfunction, left ventricular hypertrophy and accelerated atherosclerosis are common outcomes of fluid overload and accompanying hypertension.[577-582] The age of incident patients on dialysis programmes is now significantly higher than those started two decades ago. In relation to this the prevalence of many co-morbidities such as diabetes, ischaemic heart disease and cerebrovascular disease is much greater in the current incident dialysis population, features which may amplify the morbidity and mortality associated with inadequately controlled volume state. Thus it is of paramount importance that the volume state in this population is rigorously managed.

The Lister Renal Unit has adopted an incremental high-flux haemodialysis programme since its inception. Patients are dialysed for relatively short hours whilst they retain some native kidney function. Dialysis times are prescribed to achieve a total 2-pool Kt/V for thrice weekly treatments of 1.2 per session (total Kt/V = dialysis Kt/V + residual renal Kt/V).

The purpose of this study was to compare first year outcomes (weight reduction and blood pressure) in the Lister with published results from Tassin. The characteristics of the dialysis programmes in the two centres are very different. The Tassin results were achieved using conventional dialysis techniques and long treatment times (8 hours). The Lister programme using incremental high-flux biocompatible dialysis with short treatment times (mean during the first year <3 hours).

6.1.2 Subjects and Methods

We conducted a retrospective analysis on a cohort of patients who started dialysis in the decade between 1991 and 2000 to assess blood pressure control, dry weight trends, nutrition and antihypertensive drug use in the first twelve months of dialysis therapy. This period was chosen to be contemporaneous with the data presented in the Charra paper.

6.1.2.1 Renal Database: (Renal Plus)

The renal unit at the Lister Hospital has accumulated demographic and clinical data on all patients undergoing dialysis from 1991 to the present. Data was collected using Proton Information management system until 1999. After this time a highly customised Database Management System was developed in-house running on Microsoft SQL Server platform (Renal Plus). Relevant pathology results are downloaded from the Hospital's pathology system on to the SQL Server 4 times a day including results from Satellite Renal Units. Specific queries can be run with data extraction in Excel format.

6.1.2.2 Search Criteria:

We used the following search criteria

- Patients initiating chronic haemodialysis in the decade between 1/1/91-31/12/00.
- Minimal duration on dialysis 12 months continuously.
- Data collected for 0, 3, 6 & 12 months after starting dialysis
- The following data was abstracted at each time point: age, sex, the presence or absence of diabetes, pre-and post dialysis weights, pre-dialysis blood pressure, anti-hypertensive medication, residual renal function (urea clearance), normalised protein catabolic rate (nPCR), serum albumin, serum sodium, haemoglobin levels.
-

6.1.3 Results:

Three hundred and seventy six patients were identified from the data base. There were 257 men and 119 women. The mean age of the patients at dialysis initiation was 60 ± 15 years. Diabetes was present in 55. At the time of data collection (Jan 2005) 77 patients had continued on haemodialysis, 49 had been transplanted and 22 had moved out of the area. Two hundred and twenty six patients had died.

6.1.3.1 Changes in Post-dialysis weight:

Post-dialysis weight decreased 3 months following dialysis initiation ($p < 0.001$) with the maximum reduction being evident at 6 months ($p < 0.027$ with respect to 3 month value). There was non-significant increase in weight between months 6 and 12. (Figure 6.2)

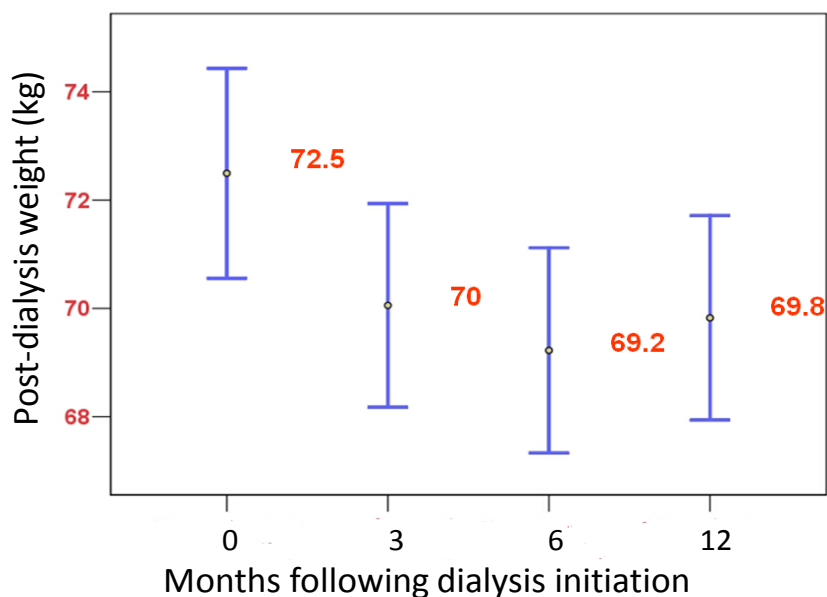

Figure 6.1.2: Error bars representing post-dialysis weight during the first 12 months following dialysis initiation in 376 dialysis patients

The same pattern was apparent in diabetics and non-diabetics except that diabetics were heavier. Weight gain apparent at 12 months was confined to the non-diabetic group (Figure 6.3)

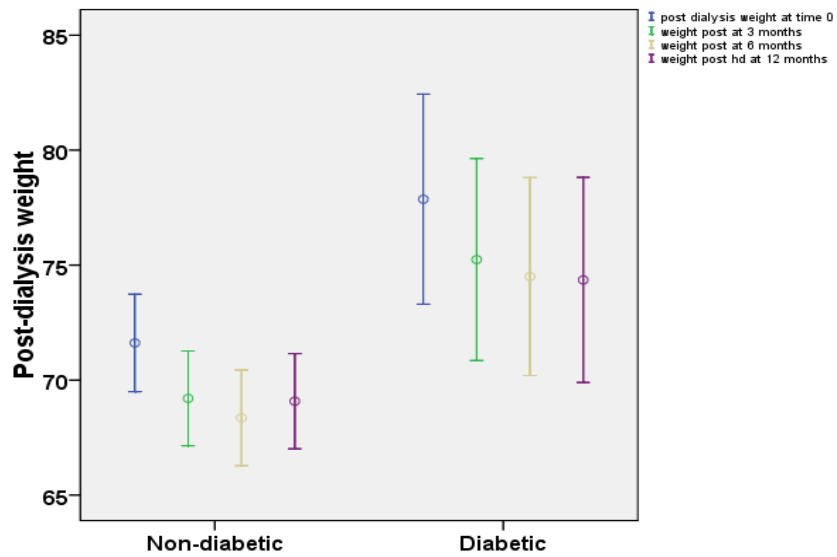

Figure 6.1.3: Comparison of post dialysis weights over the first 12 months following dialysis initiation in 55 haemodialysis patients with diabetes and 321 without diabetes.

6.1.3.2 Blood Pressure trends

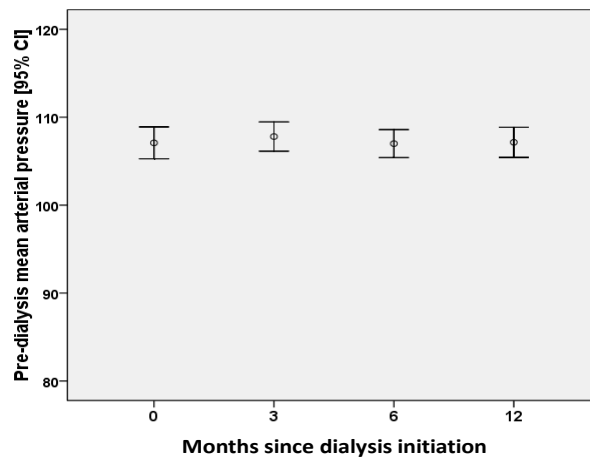

Figure 6.1.4 : Pre-dialysis mean arterial blood pressure trends in 362 patients at dialysis initiation and at 3, 6, and 12 months post-initiation

There were no differences in pre-dialysis systolic, diastolic or mean arterial blood pressure over the whole 12 month period. Figure 6.4 illustrates mean arterial pressures at these time points. There was an insignificant fall in the proportion of patients taking antihypertensive medication between initiation and 3 months, followed by a subsequent non-significant rise at 6 months and a further larger rise, so that by 12 months the proportion of patients on antihypertensive medication was significantly greater than at initiation ($p < 0.001$, Table 6.1.1)

Table 6.1.1 Antihypertensive medication in 376 patients at 3, 6 and 12 months following dialysis initiation.

	Initiation	3 months	6 months	12 months
On Antihypertensives	193	187	206	240
Not on Antihypertensives	183	189	170	136
% on Antihypertensives	51.3	50.3	55.8	63.8
p-value	Reference	NS	NS	<0.001

6.1.3.3 Correlation between MAP and weight reduction:

There was no significant correlation between change in post-dialysis weight over the 12 month period and change in pre-dialysis mean arterial blood pressure over the same period (Figure 6.5)

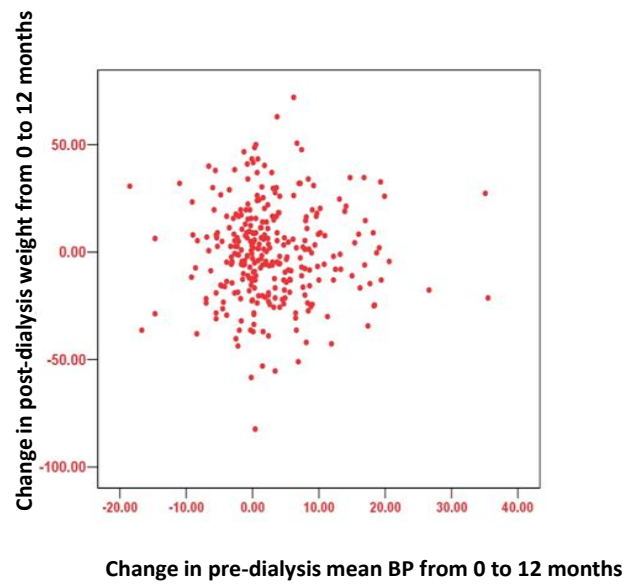

Figure 6.1.5: Scatter plot depicting change in weight and change in pre-dialysis mean arterial pressure during the first 12 months of dialysis

6.1.3.4 Incremental dialysis and residual renal function:

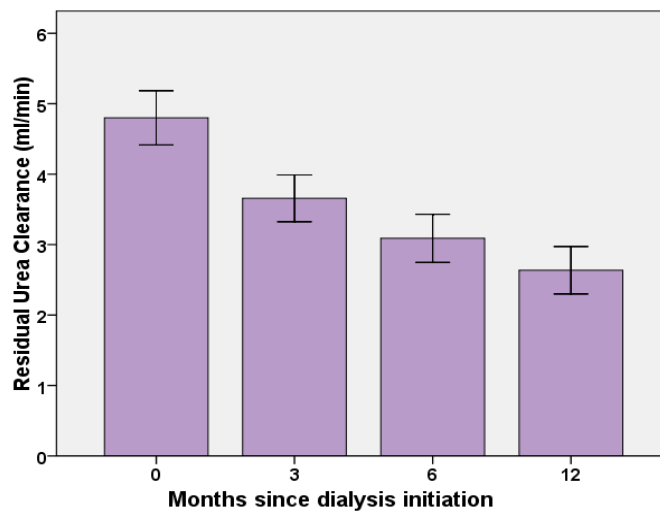

Figure 6.1.6: Fall in residual renal function during first year of dialysis in 376 incident dialysis patients at the Lister

There was a successive fall in KRU (renal urea clearance) throughout the study period (figure 6.6). To compensate for this loss of residual function mean dialysis time (td) increased successively during the same period from 148 ± 31 min during the first 3 months to 161 ± 43 min at 12 months ($p < 0.001$). The mean serum sodium did not change throughout the study period, ranging from 138.9 to 139.2 mmol/l.

6.1.3.5 Nutritional Status

There was evidence of an improvement in nutritional status during the 12 months after dialysis initiation, both in terms of serial nPCR and in serum albumin estimate (table). In addition the haemoglobin level increased throughout the study period (table 6.1.2)

Table 6.1.2: Nutritional parameters and haemoglobin in 376 haemodialysis in the first 12 months following dialysis initiation. *Note that only 188 nPCR readings were available at baseline – corresponding to all those estimates carried out in the first month after initiation

	initiation	3 months	6 months	12 months
Serum albumin (g/dl)	35.0 ± 6.6	36.2 ± 5.0	36.8 ± 5.5	37.2 ± 4.8
p-value	Reference	<0.001	<0.001	<0.001
nPCR*	0.85 ± 0.28	0.92 ± 0.22	0.93 ± 0.22	0.93 ± 0.21
p-value	Reference	<0.001	<0.001	<0.001
Haemoglobin	9.5 ± 1.8	9.6 ± 1.4	10.5 ± 1.7	10.9 ± 1.7
p-value	Reference	NS	<0.001	<0.001

6.1.4 Discussion:

Our analysis highlights major differences from the published results at Tassin. In Tassin probing for dry weight produced as an early reduction in body weight as fluid was removed. After a lag period,

normalisation of blood pressure occurred. This persisted as body weight increased towards the end of the study period. Presumably resulted from an increase in flesh-weight as patients health improved on the treatment. All this was achieved despite a massive reduction in the use of antihypertensive agents during the first few months after initiation. In our patients there was a similar fall in weight during the initial phase of the treatment which was not accompanied by a fall in mean blood pressure levels, nor by a significant change in the use of antihypertensive agents. In fact the use of antihypertensive agents increased towards the end of the study period. Hence we have described a dissociation between weight reduction and blood pressure. It is highly likely that the initial weight reduction was the result of fluid removal than loss of flesh weight since there was an improvement in nutritional status during this time, evidenced by an increase in nPCR and serum albumin. There was also a small increase in weight towards the end of the study period, at least in the non-diabetic patients, presumably also an indication of an increase in flesh weight. So, in these two centres, it appears the similar amounts of fluid are removed in the weeks after dialysis initiation, but with very different effects on blood pressure control.

These differences probably result from major differences in the study populations, dialysis regimes and dialysis management practices. The age range of the Tassin and Lister populations was markedly different (Figure 6.7), with Tassin showing a flat age profile[583] whilst that at the Lister was heavily skewed to the elderly. This entails the likelihood of there being a considerably higher co-morbid load carried by the Lister population. In keeping with this the percentage of the population with diabetic nephropathy in the Lister (14.7%) was almost twice that in Tassin (8.2%).

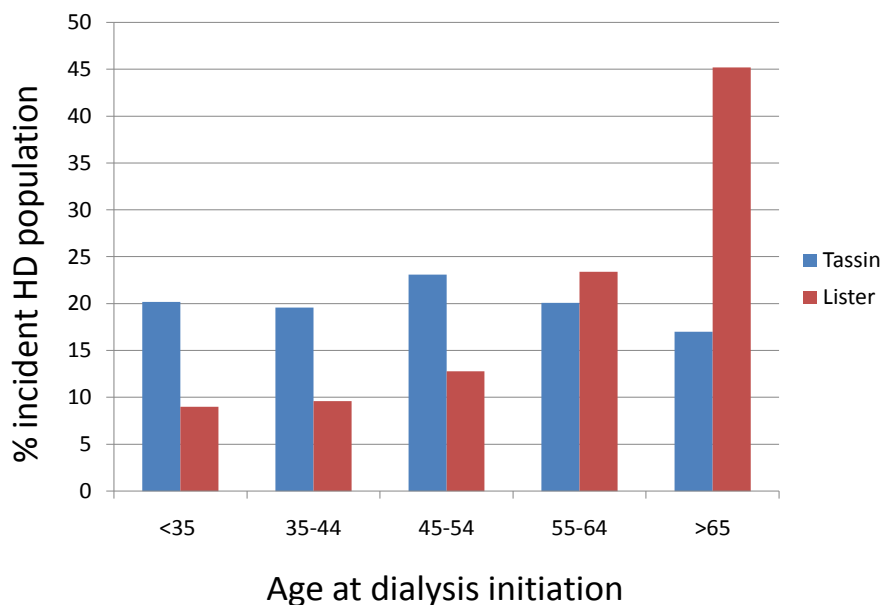

Figure 6.1.7: Comparative age distributions of Tassin and Lister incident dialysis populations (see text for details)

There were major differences too in the dialysis regimes. Patients at Tassin dialysed for 8 hours using cuprophane membranes and with acetate as buffer. The regime at the Lister included shorter hours, taking into account residual renal function, the use of synthetic biocompatible membranes and bicarbonate as buffer. Use of shorter dialysis times would hinder the achievement of adequate fluid removal. Acetate is a vasodilator and may have contributed to blood pressure control in the Tassin population. Dialysis fluid composition in the time period concerned was similar apart from differences in the buffer anion (Table 6.3). Other differences in practice were also likely to have been in operation, with a less aggressive approach to fluid removal during probing for dry weight at the Lister. This was predicated by the need to prevent intradialytic hypotension in patients with greater age and comorbidity. There was also likely to have been a reluctance to aggressively reduce anti-hypertensive medication at the Lister, not least since many patients were taking agents such as beta-blockers and ACE-inhibitors for underlying cardiac problems. There is evidence for the benefit use of such agents in haemodialysis patients[584]. There are other possible differences in practice patterns, the most relevant of which

probably relates to the intensity of sodium restriction. In Tassin this is rigorously practised, in the Lister, less so.

Table 6.1.3: Dialysis Fluid composition in Lister and Tassin

	Lister	Tassin
sodium (mmol/l)	138	138
potassium (mmol/l)	2	1.5
chloride (mmol/l)	106	106
bicarbonate (mmol/l)	35	
acetate (mmol/l)	3	35
calcium (mmol/l)	1.75	1.75
magnesium (mmol/l)	0.25	0.75
glucose (mmol/l)	5.5	0

The other major difference between the two units is the accent on residual renal function in the Lister programme. Although residual renal function declined during the study period, the mean KRU was still around 3 ml/min at 12 months (approximately equivalent to a creatinine clearance of 6 ml/min). No mention is made of residual renal function in reports of the Tassin programme. It is assumed in the descriptions that residual renal function is lost very rapidly after dialysis initiation, and in programmes in which there is aggressive fluid removal during probing for dry weight, this assumption is probably correct. Aggressive drying out in other studies has been shown to abolish residual renal function in other studies[194]. Whether this is the appropriate strategy in all patients is not known. What is known though is that preserved residual renal function may have many benefits including reduced ultrafiltration requirement and decreased mortality[192].

In conclusion, this study has illustrated major differences between the Tassin and Lister experiences. The better blood pressure control in Tassin relates to many factors including case-mix, dialysis regime – particularly with respect to the duration of dialysis sessions, and other practice patterns including the intensity of salt restriction, and the rigor with which probing for dry weight is pursued. The comparison

highlights the difficulties of applying aggressive fluid management strategies in short hours treatments in ageing haemodialysis populations with increasing comorbidity. This sets the scene for remainder of the clinical studies described in this thesis. These studies deploy techniques with the potential to assist in the fluid management of patients in such settings.

Chapter 6.2

Dual Compartment monitoring: A pilot study

The utility of CSBA and RBV monitoring of fluid removal during haemodialysis in stable patients

6.2.1 Introduction

The potential to simultaneously monitor changes in the blood volume compartment (relative blood volume – RBV) and the extracellular fluid (ECF) has been alluded to in earlier chapters. The facility for online blood volume monitoring (BVM) is a feature of many modern haemodialysis machine. The means to monitor changes in the ECF volume using continuous segmental bio-impedance (CSBA) has been described earlier.

Dual compartment monitoring has the potential to provide real-time information relating to the fluid shifts between these compartments which constitute plasma refill. The rate of plasma refill is the major determinant of adaptation to fluid removal, and along with the ultrafiltration rate, the main determinant of haemodynamic stability during haemodialysis. This pilot study is the first application of this technology.

6.2.2 Materials, subjects and methods

6.2.2.1 Patients

Nine patients were studied. Their clinical characteristics are detailed in Table 6.2.1. All had a clinically determined dry weight, were on haemodialysis for longer than 3 months, dialysed through an arteriovenous fistula, had a blood haemoglobin concentration greater than 11g/dL and a serum albumin greater than 30g/dL. None of the studied patients had dialysis related hypotension in the preceding six weeks.

6.2.2.2 Dialysis Prescription

Patients were dialysed thrice weekly on high-flux membranes to a minimum target total Kt/V of 1.2. Full details of the dialysis programme and schedules have been discussed in earlier chapter (5 and 6.1)

6.2.3 Techniques and Materials

6.2.3.1 Blood Pressure Monitoring

The investigator used the in-built BP module of the Fresenius Dialysis Delivery System to record MAP.

6.2.3.2 Bioimpedance

Hydra ECF/ICF Model 4200 (Xitron-Tech, San Diego, USA) was used for BIA. Multifrequency BIA was used to measure ECF resistance (R_{ECF}) with a spectrum of 20 frequencies used for modelling between 5KHz and 200KHz. Measurement errors were lower than 1Ω for Z and less than 1° for θ at the measured frequency range. The injected current was between $50\mu A$ to $700\mu A$.

Continuous segmental bioimpedance data was obtained from a 10 cm segment of the lower leg contralateral to the side of the AVF. (Fig 6.2.1) Gel electrodes (surface area $6cm^2$) were used to achieve robust skin contact. The calf segment was measured 10 cm from the tibial tuberosity. Voltage (V) electrodes were placed on the anterolateral aspect of the leg. A second voltage electrode was placed 10 cm below the first with the longitudinal axis of the electrodes parallel and in exact vertical alignment. The circumference of the calf segment was measured at the point of placement of the first and the second voltage electrodes. The circumference measured at the point of placement of the first voltage electrode was designated L1 and the second L2. This data along with the length of the segment (10cm) was input into the Hydra 4200 software interface of the Xitron device to acquire the volume of the segment measured. (*.VOL file, Chapter 5, Section 5.3.3). The volume data was not used for data analysis. The injection electrodes (I) were placed proximal to the upper voltage and distal to the lower voltage electrode separated by 3 cm.

Before application of the electrodes the skin was cleaned with alcohol wipes. Patients with excess hair over the lower leg were shaved and skin cleaned with warm water and dried before using alcohol wipes.

CSBA data was collected continuously by connecting the Hydra 4200 to a Personal Computer laptop through a serial port. Raw and modelled R_{ECF} (Extracellular fluid Resistance) data were manipulated through an excel sheet. The RBV and CSBA data were time synchronised. (See below)

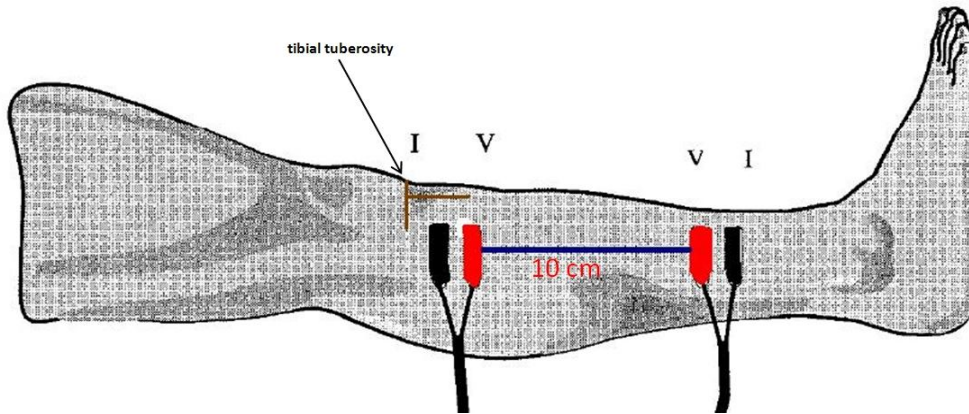

Figure 6.2.1:

Placement of gel electrodes for calf CSBA: Vertical line represents tibial tuberosity (arrow). The horizontal line adjoining this represents a length of 10cm. (not to scale). (V: voltage electrode, I: Injection electrode)

6.2.3.2 Blood Volume Monitoring

The built-in Fresenius BVM module was used to record RBV data. This was described in detail in the previous report. Fresenius BVM lines were used to prime the dialysis machine (Fresenius 4008H). These lines had a built in glass cuvette that fitted into the BVM module. The BVM module was calibrated as per the manufacturer's instructions. Biofeedback option was switched off from the main dialyser menu.

6.2.3.3 Data management

MAP, ultrafiltration, and RBV data was extracted via a previously reported Finesse/Medcomp data management system. CSBA data was collected continuously by connecting the Hydra 4200 to a Personal Computer laptop through a serial port.

6.2.4 Study Methodology

Each patient was studied during two dialysis sessions, on the same week day over two successive weeks. The adequacy target for each session was the same ($2 \text{ pool Kt/V} > 1.2$). Ultrafiltration was performed at a uniform rate during the first monitored session. In the second monitored session pulse ultrafiltration

was carried out. During this session 40% of the patients ultrafiltration was removed in the first part of the session ($T_d - 85$ minutes). Following this there was a 10 minute rebound period of isovolaemic dialysis. In the last 75 minutes of the session there were 3 short pulses of UF (15 minutes duration). During each pulse 20% of the ultrafiltration requirement was removed. Each pulse was followed by a rebound period (10 minutes duration) during which isovolemic dialysis was carried out. Other details of the ultrafiltration parameters are set out in Table 6.2.1.

6.2.5 Data Analysis:

The resistance data and blood volume data was plotted against dialysis duration. Calf segment resistance was a surrogate marker of extracellular fluid volume (ECF) and the rate of change in ECF resistance (R_{ECF}) was a marker of vascular refill from ECF to intravascular volume. The ratio of R_{ECF} at time '0' and R_{ECF} at time 't' was termed Relative Resistance (Ro/Rt). (expressed as percentage). Ro/Rt decreased throughout dialysis. RBV and Ro/Rt were plotted together against duration of dialysis. Curves generated for the whole duration of dialysis and the various phases of pulse UF and subsequent rebounds were analysed. Whole body bioimpedance measurements were also taken at the start and end of the dialysis session.

Table 6.2.1: Patient characteristics and ultrafiltration (UF) prescription (data not normally distributed; median \pm SD)

Parameter	n=9
Age	50 \pm 16
Vintage (months)	26.2 \pm 20
Length of dialysis session (min)	194 \pm 32
UF volume (Normal)	2810 \pm 792 (ml)
UF Volume (Perturbation)	2793 \pm 907 (ml)
Dry Weight (kg)	75.5 \pm 7.8
Average UF Pulse volume	550 (ml)

6.2.6 Results

Table 6.2.1 shows the results in each monitored haemodialysis phase (constant ultrafiltration rate v pulsed ultrafiltration), for ultrafiltration volume (UF), change in RBV (Δ RBV), Extracellular Fluid volume estimates from pre- and post-dialysis Whole Body bioimpedance ($WBIA_{ECF}$), pre- and post-dialysis Extracellular fluid Resistance from calf segmental bioimpedance (R_{ECF-S}). There were no significant differences in the UF volumes in each haemodialysis phase, nor were there difference in the degree of change of RBV. There were similar falls in ($WBIA_{ECF}$) in during the phase of constant rate ultrafiltration and pulsed ultrafiltration. In both phases, ECF resistance (R_{ECF}) increased throughout the dialysis session, signifying a decreasing ECF.

Table 6.2.2. Bioimpedance Profiles

Id	R_{ECF-S} N*		R_{ECF-S} P''		$WBIA_{ECF}$ N*		$WBIA_{ECF}$ P''		Δ_{RBV}		UF	
	Start	End	Start	End	Start	End	Start	End	N*	P''	N*	P''
1	47.63	55.38	54.81	63.48	17.64	16.57	18.95	17.16	12.4	11.8	2600	2600
2	51.02	66.65	58.72	74.21	22.1	18.06	18.97	17.43	17	10.5	3118	2700
3	45.54	58.7	49.49	63.32	21.57	18.56	21.33	18.78	19.2	11.8	3900	3040
4	53.6	69.88	50.98	60.7	21.07	19.82	20.66	19.79	4.2	6.4	1200	1100
5	79.68	116.81	86.15	124.8	13.56	11.08	14.4	11.17	14.6	19.6	2533	2620
6	42.72	50.43	45.3	56.51	24.18	21.12	23.35	19.69	20.9	18.6	2744	2995
7	59.27	87.92	62.43	92.52	19.14	15.51	18.27	15.4	11	8.9	2601	2144
8	54.38	70.97	47.39	85.75	21.77	19.12	22.63	18.76	11.9	13.7	2800	3538
9	58.75	84.37	55.86	81.22	16.31	13.58	17.42	14.06	23.3	27.6	3800	4396

* Normal Ultrafiltration '' Perturbation Ultrafiltration R_{ECF-S} : Extracellular Fluid Resistance (Segmental, calf)
 $WBIA_{ECF}$: Whole Body Impedance Analysis for Extracellular Fluid
 Δ_{RBV} : Change in Relative Blood Volume

The changes in calf circumference pre- and post-dialysis are summarized below. The circumferences L1 and L2 were lower at the end of the dialysis session. The change in L1 for the normal dialysis session was 0.7 ± 0.3 cm (mean \pm SD) and that of L2 was 0.37 ± 0.3 cm. A similar change was measured for the session with the pulse UF. (L1 0.8 ± 0.3 and L2 0.37 ± 0.3 cm respectively)

Table 6.2.3. Calf circumference data

(L1 : circumference in cm at the point of placement of upper 'V' electrode, L2 : circumference in cm at the point of placement of lower 'V' electrode)

Subject Id	Normal UF		Pulse UF					
	Start		End		Start		End	
	L1	L2	L1	L2	L1	L2	L1	L2
1	33.1	28.7	32.6	28.6	34	28.4	33.2	28.1
2	32	29.6	31.1	28.9	33.8	28.8	32.9	28.3
3	33.5	27	32.5	26.4	33.8	27.3	32.9	26.8
4	35.6	27.6	35	27.3	36	28.6	34.9	27.9
5	30.2	22.6	30	22.3	30.4	22.4	29.6	22.3
6	28.8	22.1	28.4	21.9	28.6	22	28.1	21.7
7	34.5	27.3	33.6	27.2	N/A	N/A	N/A	N/A
8	31.1	24	30.5	23.9	31.8	24.5	31.1	24.3
9	34.5	26.8	33.4	25.9	34.7	26.6	33.8	26.2

Figure 6.2.2 shows the RBV, and ECF Relative Resistance (R_o/R_t) plots during dialysis with a constant ultrafiltration rate, in a typical patient. Each of these plots showed a smooth curvilinear decline throughout the session, signifying a reducing declining blood volume and a reducing ECF. The ICF resistance curve (R_{oi}/R_{ti}) did not follow a uniform trajectory, and was not plotted in the pulse ultrafiltration phase.

Figure 6.2.3 depicts the RBV and ECF Relative Resistance plots in a typical patient during the pulse ultrafiltration phase of the study. During the initial part of the session, both parameters fall in a smooth curvilinear fashion. In the 10 minute isovolaemic dialysis period following this, the RBV trace rebounded upwards as plasma refilling continued in the absence of ultrafiltration. The ECF Relative Resistance trace continued on its former trajectory as fluid continued to leave the ECF. During the first ultrafiltration pulse the RBV trace fell dramatically, whilst the ECF Relative Resistance trace continued in its previously established trajectory. In the rebound period the RBV trace again rebounded upwards, whilst the ECF Relative Resistance continued to fall. The same pattern occurred during and after the third ultrafiltration pulse. Considering the ECF Relative Resistance Curve during the whole dialysis session, there appeared to be a flattening out of the curve- a reduction in the rate of fall in rate of fall of ECF Relative Resistance toward the end of the session, indicating a reducing rate of reduction of the ECF compartment.

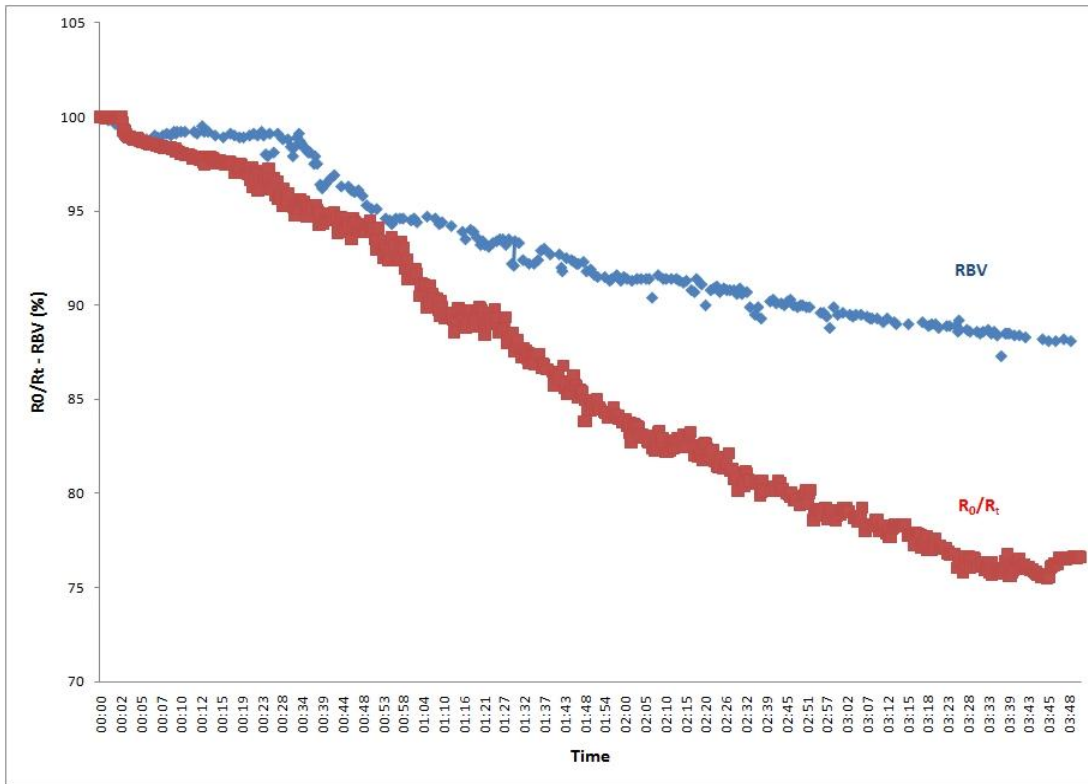

Figure 6.2.2: RBV, ECF Relative Resistance (R_o/R_t) and ICF Relative Resistance (R_{0i}/R_{ti}) trends in a typical patient during a haemodialysis session dialysis with constant ultrafiltration rate

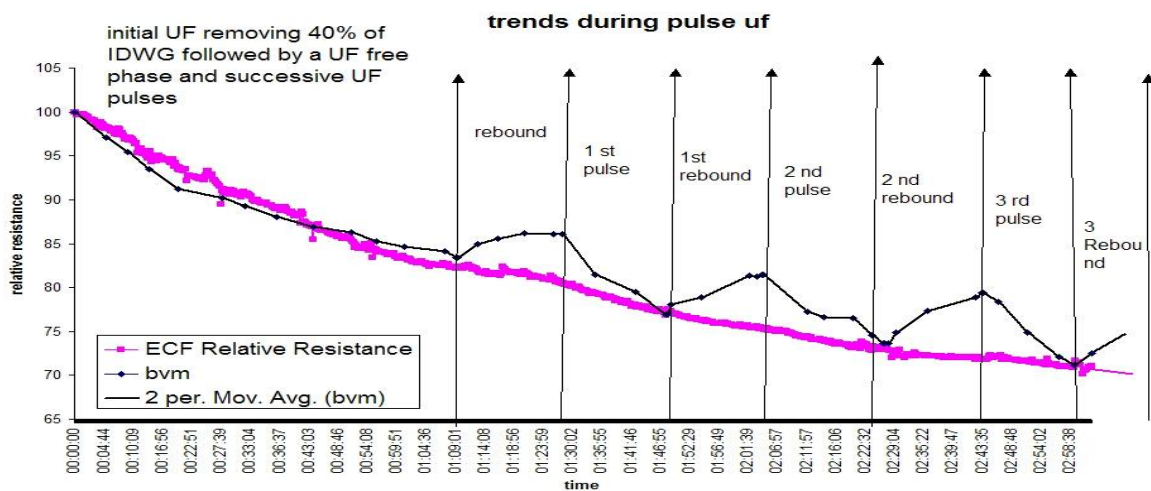

Figure 6.2.3: RBV and ECF Relative Resistance trends in a typical patient during haemodialysis with pulse ultrafiltration

6.2.7 Analysis of RBV-R_{ECF} profiles:

The curves illustrate ECF compartment emptying during dialysis associated with the changes in the intravascular volume. During the rebound phase following the UF pulses, the RBV increases by refill from the ECF compartment. During subsequent pulses the vascular refill diminishes and the increments in RBV during the subsequent rebound phase reduce. In patients who are approaching their dry weight toward the end of dialysis session, the last rebound phase would be expected to be associated with minimal or no change in the blood volume associated with an almost “empty” ECF compartment. This would be reflected in a flattening of the ECF Resistance trace. Patients who remain over-hydrated at the end of dialysis will exhibit a brisk RBV rebound associated with a continuing fall in ECF Relative Resistance.

In order to quantify these changes we used an arbitrary parameter of refill (Refill Ratio, Figure 6.2.4 below) and have illustrated this by comparing the rebound traces after the first and third pulses. Patients who remain over-hydrated at the end of dialysis will have RBV and Ro/Rt traces converging towards each other whereas patients close to their dry weights at the end of the session will have these curves tending towards parallel. The figure (6.2.4) below illustrates this concept. In the upper panel, during the first rebound the RBV volume has rebounded rapidly from 90.6% at the beginning of the rebound period to 94.9% at the end. At the same time Ro/Rt, having been adjusted to 100% by re-calculating R_{ECF} ratio at the start of the rebound period, has continue to fall from 100% to 97.1%. This signifies that the patient is overhydrated – with rapid refilling of the blood compartment from the ECF. This is reflected in a high refill ratio of 4.3, where refill ratio = $[(Ro/Rt)_{initial} - RBV_{initial}] / [(Ro/Rt)_{final} - RBV_{final}] = [100 - 90.6] / [97.07 - 94.9]$.

Towards the end of dialysis, during rebound 3, there is minimal change in RBV, and in Ro/Rt equating to a refill ratio of 1.2. This indicates minimal fluid shift from the ECF to the blood volume. This suggests that there is a paucity of mobilisable fluid in the ECF and implies that further ultrafiltration is likely to result in haemodynamic instability. The closer the refill ratio is to unity, the nearer the patient is, if not to their dry weight, then to their best achievable weight for that particular dialysis session. The lower panel

illustrates the same principles in a further patient with less dramatic changes in the refill ratio from rebound 1 to rebound 3, but with a ratio which, though falling from 2 to 1.6, still remains at level which might indicate that there has been inadequate fluid removal.

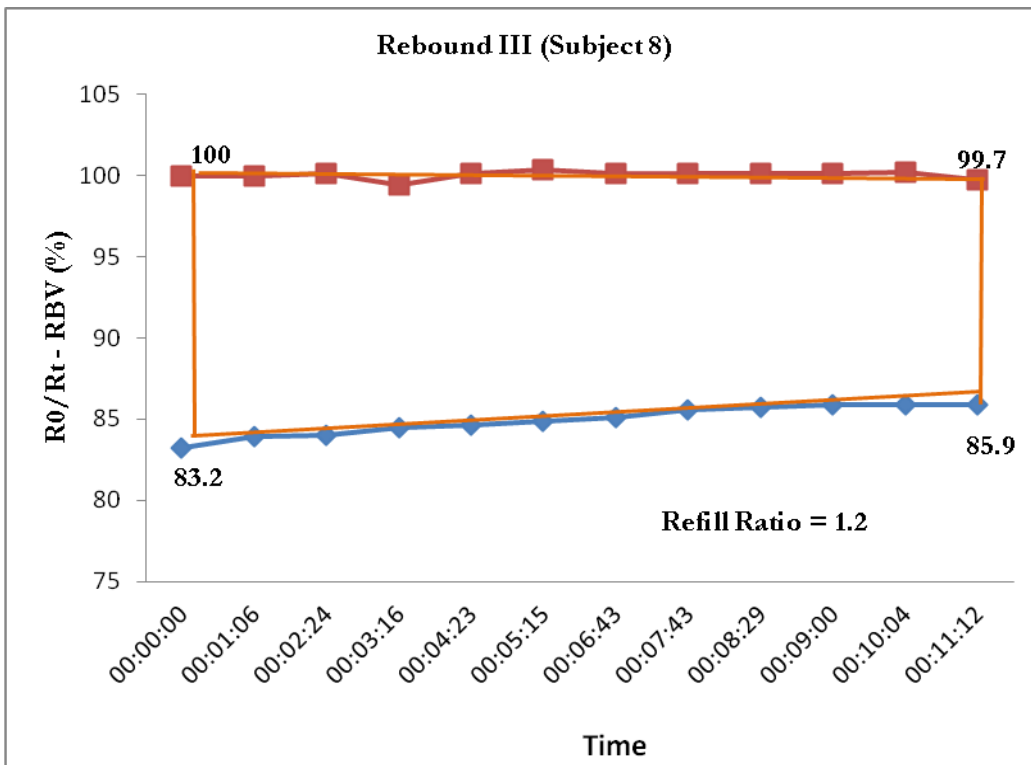
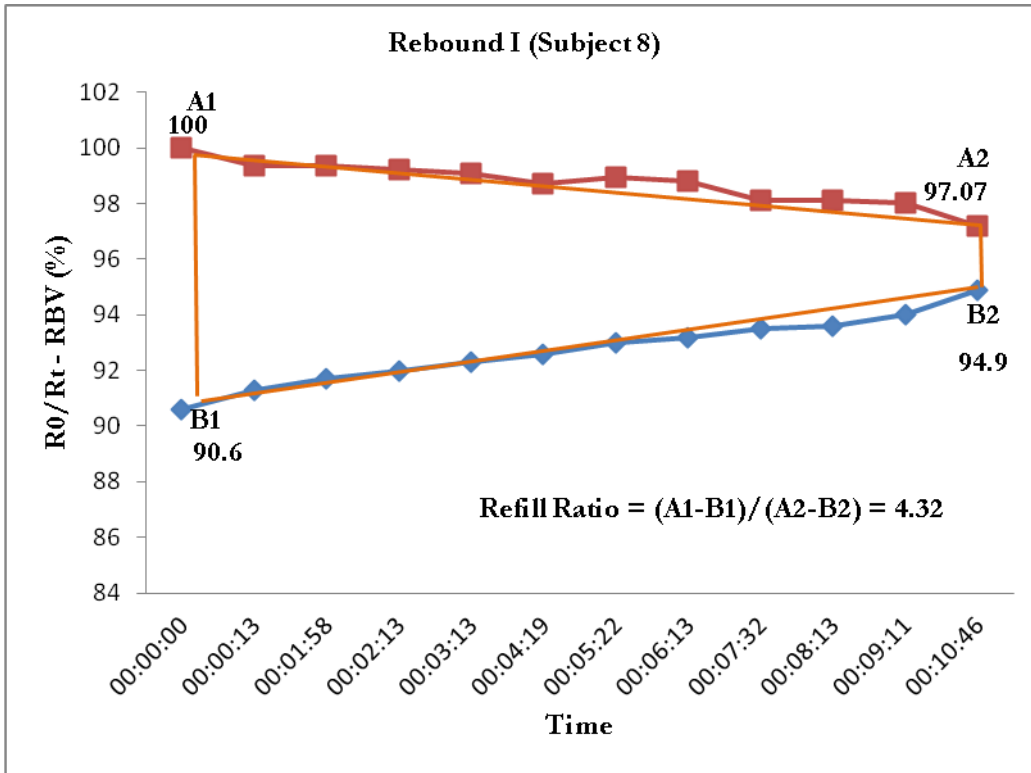

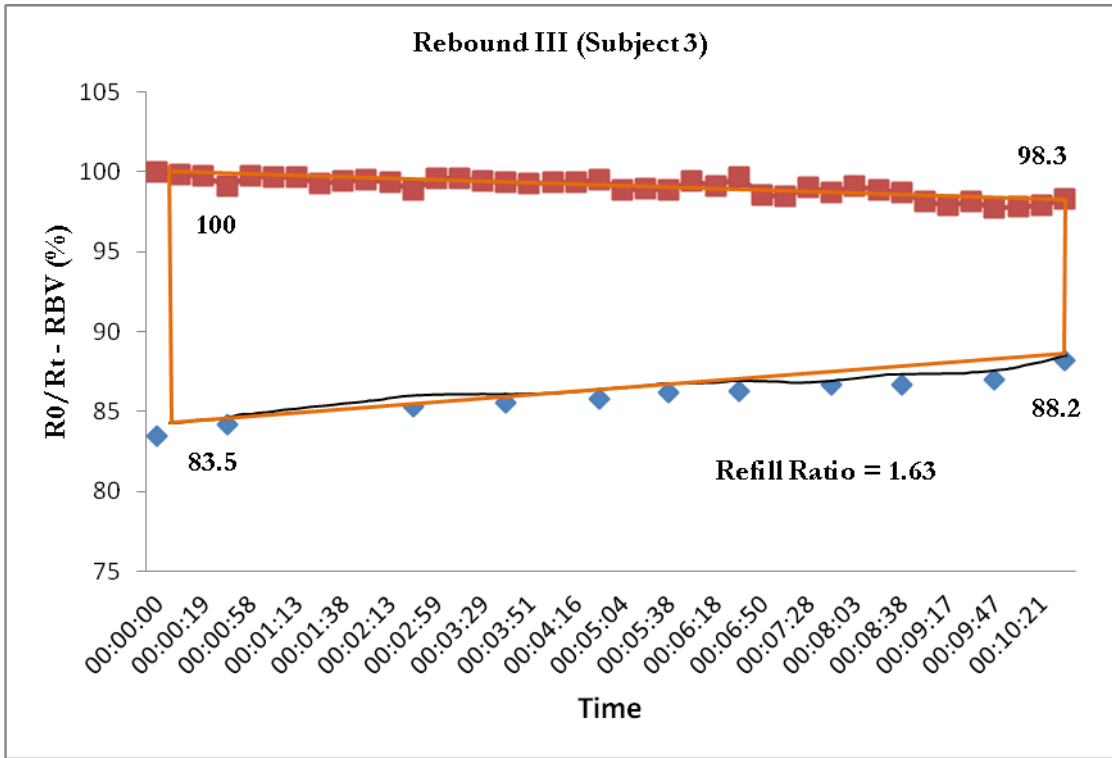
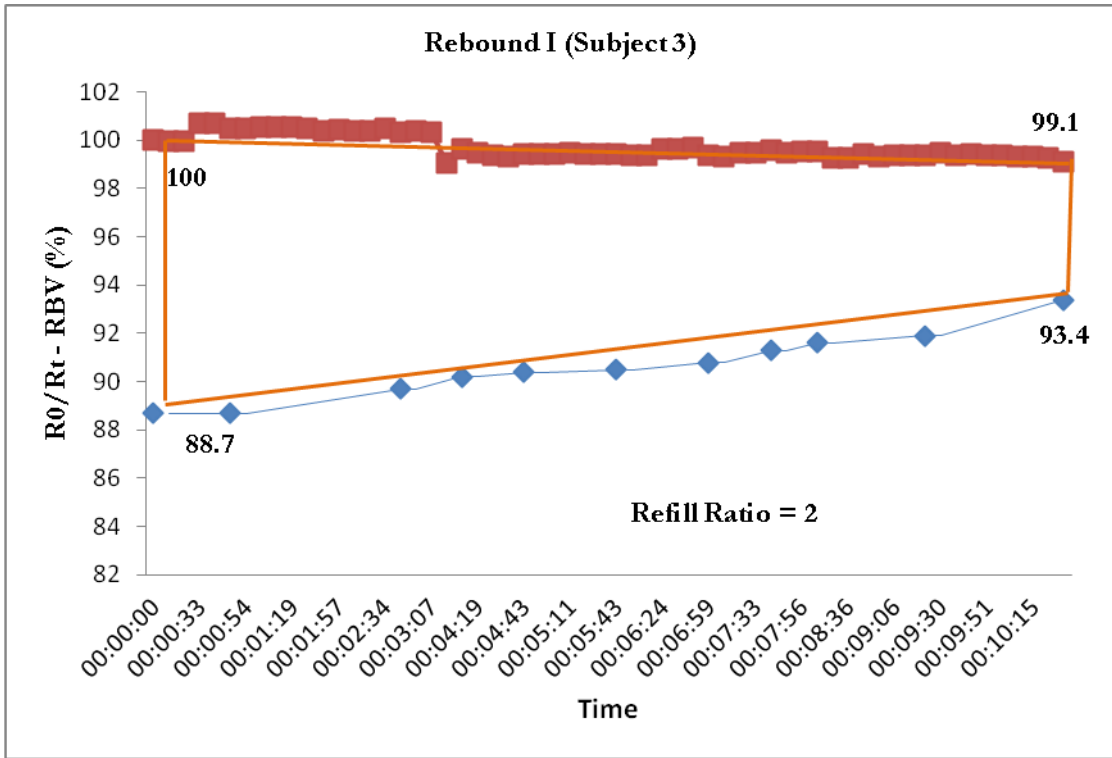

Figure 6.2.4: Concept of refill ratio: First and third Rebound phases illustrated in Subjects 8 and 3; refill ratio falls from 4.32 to 1.2 in Subject 8 indicating close proximity to dry weight; in Subject 3 the fall is less pronounced suggestive of hypervolemia

The refill ratios for all 9 patients in the pilot study are depicted in Table 6.2.4. The table compares the ratios in the first rebound phase and the third. There was a significant difference between the mean refill ratios during the first and third rebound phases (1.97 ± 0.92 v 1.32 ± 0.20 ; $p < 0.01$), indicating a closer proximity to dry weight (or best achievable weight) in the latter stages of the treatment.

Table 6.2.4: Refill ratio for all patients in pilot study.

Pt id	Refill Ratio Rebound 1	Refill Ratio Rebound 3
1	1.9	1.6
2	1.6	1.2
3	2	1.6
4	2	1.5
5	1.5	1.2
6	1.4	1.3
7	1.8	1.2
8	4.3	1.3
9	1.2	1.1

6.2.8 Discussion and Conclusions

The work demonstrates the potential usefulness of combined bioimpedance and blood volume monitoring in assessing the fluid state of stable patients. Ultrafiltration in pulses allows the ready assessment of the rapidity of vascular refill. Monitoring the ECF compartment continuously using bioimpedance can provide useful information regarding the rate of refill as evidenced by the flattening of the Resistance curve towards the end of dialysis. Quantifying this pattern change using the arbitrary refill ratio, may allow identification of patients who remain over-hydrated at the end of dialysis.

The technique of bioimpedance has its limitations when used to determine the Total Body Water (TBW) and ECF volumes in dialysis patients most of whom have abnormal body water distribution. However continuous monitoring of segmental ECF resistances provides useful information when combined with blood volume monitoring as demonstrated in the study. ECF resistance values can be used as a surrogate for ECF emptying without the need to calculate the actual volumes, using empirical algorithms. CSBA has

not been used in this way previously and coupling it with continuous blood volume monitoring has the potential to provide unique information on the impact of ultrafiltration on fluid compartments, which may of considerable value in monitoring fluid removal in dialysis patients. This may prove beneficial both in the reduction of intradialytic symptoms and in defining target weights with greater accuracy.

The parameter the Refill Ratio (initially referred to as the parallelity ratio), takes into account both the concept, that flattening of the RBV trace indicates no volume change in the blood compartment, and that flattening of the ECF Resistance curve indicates no volume change in the ECF. Hence a Refill Ratio equal to unity represents a state in which there is no refill – presumably because there is no mobilisable fluid in the ECF. Since this immediately follows a period of ultrafiltration, it follows that further attempts at ultrafiltration are likely to be associated with haemodynamic instability consequent to poor or absent vascular refill. In this pilot study the concept proved useful in distinguishing between the fluid states in rebound 1 and rebound 3, when the patients who were nearer their target weight. It is to be noted that, in the pilot study, a substantial proportion of UF requirements (40% of IDWG) had already been removed and a further three UF pulses were administered with a 10 minute rebound phase afterwards. Using just two UF pulses at the start and end of dialysis with a rebound phase following each pulse will amplify RBV rebound and R_0/R_t changes accentuating the difference in refill ratio between the first and the last rebound phases.

Though the concept of the Refill Ratio has shown to be potentially useful, refinements to it are possible. Refill ratio, by focussing on the beginning and the end of these curves, uses just a small proportion of the information contained within them. No account is taken of the trajectory of the curves. A more comprehensive use of this information might report the area between the curves as a proportion of the “target” area ie when the curves are parallel and refill is absent ie $[\text{area of } A1A3B3B1]/[A1A2*A2B2]$ in Figure 6.2.5. A value of unity for such a modified Refill Ratio would still indicate absence of refill

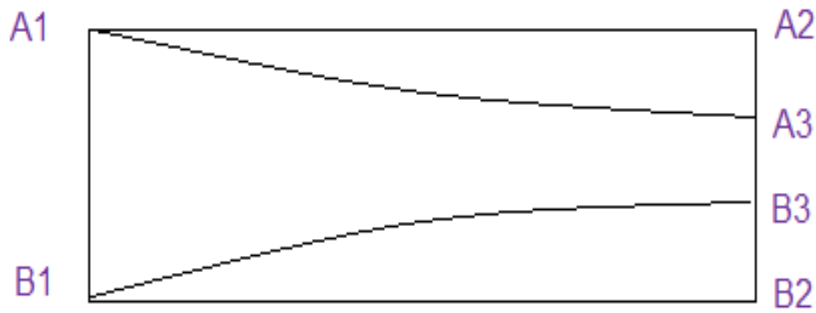

Figure 6.2.5. Suggested means for improvement of Refill Ratio. For details – see text.

To calculate this accurately would require accurate filtering of noise from measurements of RVC and ECF resistance to allow accurate determination of area by integration techniques.

It is possible to envisage such parameter being calculated in real-time during the dialysis procedure. It would require analysis of RBV and ECF Resistance curves observed during (say) a 1 to 5 minute rebound period following the cessation of ultrafiltration. The Refill ratio or modified Refill Ratio, as described above, could guide adjustment of ultrafiltration rates perhaps even in an automated fashion as part of a biofeedback loop.

Chapter 6.3

Factors influencing CSBIS

6.3.1 Introduction

The pilot BIA study described in the previous chapter establishes the potential of continuous segmental bioimpedance spectroscopy (CSBIS) technique in the assessment of the hydration state of the ECF compartment during dialysis. The changes in R_{ECF} reflecting the decrease in ECF volume and those of the RBV representing the intravascular compartment define the principle of dual compartment monitoring. The rapidity of vascular refill can be potentially defined by the patterns of decay. The changes in the R_{ECF} are largely representative of volume change but other factors influencing the CSBIS readings need to be considered particularly during dialysis.

Significant fluid and ionic shifts occur during dialysis both with and without UF consequent to the flow of the dialysate influencing electrolyte concentrations in the blood across the dialyser membrane. These ionic shifts been modelled and compared with changes in measured electrolyte concentrations at various intervals during a single dialysis session. Thews and Hutton had described exchange processes during haemodialysis with their mathematical model for sodium, potassium, chloride, acid base status, urea and water distribution. For potassium, sodium, and urea a 2-compartment model comprising ECF and ICF was proposed. Chloride and creatinine changes were defined through a 3 compartment model. Further elaborate modelling was developed for changes in other metabolic variables including changes in pH and acid base status. The model was proposed to represent the real changes in these patient variables during dialysis adequately[585;586]. Later, in 1999, Ursino and his colleagues developed and tested a model of solute changes using a three compartment model and obtained good agreement between measured changes in variables and that predicted by the model. Similar other attempts have been made over the years to facilitate individualisation of dialysate prescriptions tailored to the patients' internal milieu[587].

It follows on that, such changes in ionic concentrations may influence the conducting properties of the ECF and ICF. Sodium is the predominant cation in the ECF and potassium the abundant cation in ICF. These differences explain the different conducting properties of these fluid compartments with ECF conductivity perhaps twice as that of the ICF in health. The changes in conductivities consequent to renal

failure have not been well defined but an analysis by de Vries *et al* [316] in the eighties had not shown significant differences in the conducting properties pre- and post-HD in corresponding blood samples from six HD patients. However no comparisons were made with samples from a normal population.

A technique such as CSBIS, measuring the resistance (conversely conductance) and scaling this to volumes of individual body fluid compartments, will be influenced by changes ionic conductance. These influences may even be discernable when measurements are obtained continuously. The modelling algorithms used for ECF and TBW estimations have shown tight correlations in normal populations with isotope dilution techniques. In the dialysis population, ECF measurements made by the Sum of Segmental BioImpedance Spectroscopy (SSBIS) technique have been more accurate than that obtained by WBIS. These methods use instantaneous data at the start and end of a dialysis session to calculate the respective volumes. The pilot CSBIS data from the previous chapter shows progressive rise in ECF resistance (fall in resistance ratio R_0/R_t) due to a fall in segment volume. It is possible that some of these changes could be attributable to changes in ionic conductance inherent to the dialysis process itself. The sodium (Na) gradient between dialysate, plasma and ECF may determine the nature of this change. The robustness of vascular refill in an individual patient would ‘transmit’ these changes from the plasma to ECF and vice versa. Scharfetter *et al* had predicted a 1-2% change in ECF and 4-5% change in ECF with a 5 mmol change in ion concentration in a healthy adult of 70kg weight[352]. In altered hydration states these effects will be different.

Our study aimed to describe the effects of varying the electrolyte composition of the dialysate on the ECF trace obtained continuously through a dialysis session. Alterations in sodium content of the dialysate was

hypothesised to induce changes in the $\frac{R_0}{R_t}$ trace over and above those resulting from ultrafiltration.

Furthermore, the effects of changes in dialysate temperature and posture on the ECF trace were also studied. The SSBIS technique described by Zhu *et al* [334] had alluded to the preserved accuracy of the technique in estimating ECF and TBW when subjects changed from the standing to the supine position. This was thought to be due to the fluid redistribution effects captured better by the SSBIS technique in

comparison with WBIA. This redistribution will change individual segment volumes and we hypothesised that such changes may be apparent even if the segment volume was changing continuously.

Changes in dialysate temperatures have been shown to influence vascular stability in many previous published works (as described previously in the section on IDH) with lower dialysate temperatures and isothermic dialysis being more biocompatible. We analysed the effect of changes in the dialysate temperature during a single session hypothesising that higher dialysate temperatures will cause cutaneous vasodilation influencing the resistance of the leg segment during dialysis. A lower temperature will induce vasoconstriction. The effect of altering the dialysate temperature on vascular refill has been studied more elaborately in a subsequent chapter.

Lastly, the patterns of R_{ECF} decay during multiple dialysis sessions in individual patients were studied to describe changes in slope with respect to a weight adjusted uniform UF rate. The effect of isovolemic HD on the R_{ECF} profiles was studied to analyse the influence of the sodium gradient at the start of dialysis. Attempts were also made to determine the constancy of the initial R_{ECF} measurement when obtained over a number of dialysis sessions and the ‘spread’ of ECF resistance among a cohort of dialysis patients.

Study plan: An outline plan of the studies is shown in Table 6.3.1.

Overview: Table 6.3.1

Parameter	Component studied
Dialysate Composition	Cations <ul style="list-style-type: none"> • Sodium <ol style="list-style-type: none"> 1. Na_{146} for the first 30 min of dialysis 2. Na_{130} for minutes 31-60 min of dialysis 3. Na_{138} for rest of the dialysate session • Calcium <ol style="list-style-type: none"> 1. Ca 1.75 mmol/L for first 30 minutes of dialysis 2. Ca 1.25 mmol/L for minutes 31-60 of dialysis • Potassium <ol style="list-style-type: none"> 1. K 3 mmol/L for first 30 minutes of dialysis 2. K 2 mmol/L for minutes 31-60 of dialysis

Dialysate temperature	<ul style="list-style-type: none"> • Temperature <ol style="list-style-type: none"> 1. 35.5°C for the first 30 minutes 2. 37°C for minutes 31-60 of dialysis 3. 36°C for rest of the session
Isovolemic dialysis	<ul style="list-style-type: none"> • Sixty minutes of isovolemic HD at start
Posture	<ul style="list-style-type: none"> • Supine position vs lower leg held vertical at 90⁰ to plane of dialysis couch
Profiles over time	<ul style="list-style-type: none"> • Individual patients 10 dialysis sessions each • Constancy of R_{ECF} in individual patients

6.3.2 Materials and Methods

6.3.2.1 Subjects:

The general characteristics of the subject population have been described in the previous chapter. Twenty patients were approached to take part in the electrolyte/posture/temperature arm of the study. The studies were designed to include 10 patients in each section. Eight of the twenty patients participated in more than one section of the combined study.

Three patients were recruited for the study of R_{ECF} profiles over 10 dialysis sessions each. Thirty dialysis sessions were studied in ten patients for constancy of their R_{ECF} measurements at the commencement of dialysis. In addition, ten patients underwent isovolemic dialysis.

All patients had been on regular intermittent haemodialysis for longer than 3 months and did not suffer from episodes of IDH. The aetiologies of their ESRD were representative of nationwide data provided to the UK renal registry.

6.3.2.2 Methods:

The Xitron 4200 multifrequency bioimpedance analyser was used to collect segmental bioimpedance data. ECF resistance was the target variable with raw and volume data generated by the instrument not

retrieved for analysis. ICF compartment volumes were not collected. The Xitron device was checked for accuracy at the start of a study day using the manufacturer's quality control (QC) device of pre-specified resistance.

Relative blood volume monitoring was carried out >90% of all the monitored sessions except for the study evaluating bioimpedance data acquisition. RBV was performed using the Fresenius BVM as described earlier.

Temperature of the dialysate was altered using the Fresenius BTM operating in the observation mode (not isothermic or thermoneutral)

Fresenius 4008H dialysis delivery system was used for all the studies. The internal clocks of Fresenius 4008H, Xitron 4200 and PCs used were synchronised.

Statistical analyses were done using Prism v5 (Graph Pad) software and SPSS. R_{ECF} data was input and manipulated using Excel spreadsheets.

6.3.2.3 Procedure

6.3.2.3.1 Electrolyte composition:

The dialysate compositions were changed for individual studies. When the effect of sodium was studied, dialysate concentrations were ramped up to 146mmol/l for the first 30 minutes of dialysis, this was then followed by decreasing it by 16 mmol/L to 130mmol. This segment lasted the ensuing 30 minutes following which the dialysate sodium was put up to 138mmol/L for the rest of the dialysis session. Dialysate flow rates were not altered during any of these interventions. We anticipated no other changes in electrolyte composition of the dialysate fluid apart from the automatic change to the chloride concentrations. The dialyser user interface of Fresenius 4008H was used to change the sodium concentrations. We did not measure the dialysate sodium concentration during each phase of change to confirm the accuracy of the change. While it is possible that conductivity alterations offered through the dialysis user interface of Fresenius 4008H may not accurately translate as the exact desired fluid sodium

concentration, it would still result in three distinct phases of differing dialysate sodium concentrations. The study attempts to define the effect of these differing phases on the R_{ECF} trace over time.

When studying the effects of dialysate calcium, the first 30 minutes of a monitored session was with a dialysate calcium of 1.75mmol/L followed by dialysis against a dialysate calcium of 1.25mmol/L. The first and second 30 minutes of the dialysis session was studied for any changes in the patterns of R_{ECF} decay. A similar approach was used for the potassium study when the dialysate potassium was set at 3mmol/L for the first 30 minutes and 2mmol/L there after.

Blood samples for serum, potassium and calcium estimations, respectively for each study, were drawn at the start of dialysis, at 15 min intervals for the first 60 min and then every 30 min and at the end of dialysis.

6.3.2.3.2 Temperature and posture:

Dialysate temperature was manipulated using the Fresenius BTM. The first 30 minutes of a monitored session was with a dialysate temperature set at 37°C, the subsequent 30 minutes with 35.5°C and the rest of the session with the conventional 36°C dialysis. The participants of the study evaluating the effect of posture were asked to be supine for the first 15 minutes of the session, adopt a vertical position of lower leg at right angles to the plane of the dialysis couch for a further 15 minutes before reverting to their usual recumbent position for the rest of the session.

6.3.2.3.3 Characteristics of R_{ECF} profiles:

During this phase, patients were dialysed as per their usual prescriptions except for the isovolemic HD component when no UF was carried out for the first 60 minutes. The patients participating did not have IDWGs larger than 2L and dialysed for a minimum session duration of 180 minutes.

6.3.2.3.4 Repeatability of R_{ECF} over multiple dialysis sessions within subjects

During this study, subjects were studied over three dialysis sessions. CSBIS was carried out during these sessions with no change in dry weight.. A total of 36 sessions were studied in 12 subjects.

6.3.2.4. Data analysis:

Raw data from the Xitron bioimpedance analyser was captured in real time using the manufacturer software. Data that could not be fitted to the Cole model was discarded by the device and an audible beep alerted the investigator to this. Repeated beeps suggested poor data fitting and continued discarding until intervention. Poor data fit could be due to poor adhesion of gel electrodes, stray interference, changes in conducting properties of the skin and other unspecified factors.

Data collected was transported into Microsoft Excel® (Microsoft Corporation, WA, USA) and ‘matched’ with time identical RBV data to generate RBV-Resistance Ratio curves. Slopes of generated curves were analysed using Prism v4.5 (Graphpad Software, CA, USA) software. ANOVA was used to calculate the significance of any changes in slope between the interventions. (Obvious lack of significance was evident when slope changes were plotted, see below)

In the section where bioimpedance profiles were repeatedly obtained, curve fitting was attempted to describe the nature of Resistance Ratio decay.

6.3.3. Results:

6.3.3.1 Patient characteristics and participation

The demographics of patients participating in the electrolyte, temperature and posture parts of the study are summarised below. (n =20) (Table 6.3.2)

The initial intention was to study 10 patients in each section, but, time constraints, withdrawal of consent, equipment malfunction and patient related issues meant the numbers in each section were lower (Tables 6.3.3 and 6.3.4) Thirty three complete sessions were available across the group.

Table 6.3.2: Patient and dialysis characteristics

ID	Age	Gender	DM	VINTAGE	CAUSE_ESRD	Kt/V	W-vol	U-DV	KRU	Qb	Dx	HDF	HDF-Fr	Td
AT	62.9	M	0	0.4	DM Neph	1.77	35980	35802	5.76	250	FX80	1	0	150
CL	23.1	F	1	4.4	REFLUX	1.66	27690	27918	0.32	400	FX100	0	0.35	184
DC	63.0	M	1	3.6	PKD	1.18	38612	42085	1.33	300	FX100	1	0	210
GH	66.5	M	1	1.1	RVD	1.25	36689	29269	0	300	ARH9	1	0	206
JC	63.1	F	1	2.4	Alports	NA*	29532	NA*	0	300	ARH9	1	0	254
JBM	85.6	M	0	1.2	RVD	1.28	33520	37400	0	400	FX80	1	0	199
JW	61.4	M	1	1.9	RVD	1.4	37240	32574	1.66	350	ARH9	0	0.35	162
LD	31.0	F	1	1.9	Chronic Pyelo	1.64	28102	31215	0	450	FX100	0	0.35	210
MA	63.9	F	1	8.1	PKD	1.44	29212	28044	0	400	ARH9	0	0.35	160
WB	84.9	M	1	0.7	Unknown	2.25	34684	31030	4.63	250	FX80	1	0	180
BD	75.7	M	1	6.2	ChronicGN	1.26	37736	41654	0	400	FX100	0	0.35	196
DT	53.4	M	0	0.3	DM Neph	1.11	41387	42664	0.84	300	FX80	1	0	194
HC	57.2	F	0	5.1	DM Neph	0.97	32951	37265	0	300	BK2.1	1	0	180
JoW	83.8	F	1	3.8	Unknown	1.32	28053	22436	1	300	FX80	1	0	129
LW	46.4	M	1	0.6	CIN	1.35	49734	45265	0.08	400	FX100	0	0.35	228
PB	69.5	M	1	4.8	CGN	1.26	39459	41008	0.4	400	FX100	0	0.35	190
TM	78.0	M	1	2.1	RVD	1.26	39747	42019	0.09	350	FX100	0	0.35	212
CS	72.0	F	1	9.4	PKD	1.49	30091	27509	0	350	ARH9	1	0	191
TB	52.4	F	0	1.9	DM Neph	1.4	31636	32504	0	350	FX80	1	0	210
FK	75.1	M	1	1.6	IgA	1.3	35574	32750	0	350	FX80	1	0	194

Table 6.3.3 Reasons for withdrawal

Factors	n
Time constraints	4
BVM door open	1
Stray interference	3
Clot in venous bubble trap; circuit	1
Patient movement	2
Fresenius 4008 operational issues	3
Software malfunction	2
Withdrawal of consent	1

Table 6.3.4. Numbers in separate sub-studies

Study	n
Sodium	7
Calcium	10
Potassium	6
Posture	5
Temperature	5

The median age of the group as a whole was 64.2 years, 13 males and 5 diabetics of whom one was diet controlled. The vintage was 2.3 ± 2.5 years (median \pm SD) and there were all achieving adequacy targets. (1.31 ± 0.27 , 2 pool Kt/V). All underwent thrice weekly high flux HD with 8 patients also on HDF (post-dilutional), one patient dialysed 4 times a week and 3 had significant residual renal function (KRU > 1). Eight patients were studied more than once as part of different study subgroups. Subject PB took part in all the sub-studies (Sodium, Potassium, Temperature and Posture), CL in the calcium and posture, BD in the sodium, potassium and temperature, DT in sodium, potassium and posture, JW in calcium and potassium, TB in posture and temperature, TM in potassium and posture, and LW in sodium, potassium and temperature studies respectively. Twelve other patients were studied once.

6.3.3.2 Haemodynamic changes

The haemodynamic summary of the 33 sessions across the different sections of the combined study is tabulated below (Table 6.3.5)

Table 6.3.5: Basic clinical and haemodynamic data of patients in separate sub-studies

Calcium															
id	Duration	Pre Wgt	Pst Wgt	UF Wgt	BMI	Pulse	T-pre	T-post	SBP-Pre	DBP-Pre	SBP-Post	DBP-Post	MAP-Pre	MAP-Post	
CL	180	52.7	51.1	2	19.7	96	36.5	35.5	160	110	137	95	127	109	
DC	210	70.1	67.7	2.4	20.4	82	36.8	36.6	153	78	121	65	103	84	
GH	210	69.3	67.8	1.5	24.6	80	35.5	35.6	172	79	178	82	110	114	
JC	135	54.7	54	0.7	18.9	70	36.1	36.2	117	82	95	60	94	72	
JM	231	63.6	61.5	2.1	20.3	61	35.8	36	183	81	146	65	115	92	
JP	179	67.2	65.2	2	24.5	62	36.1	36.5	142	61	115	75	88	88	
JW	146	69.3	67.1	2.2	23.2	90	36.5	36.4	175	78	168	75	110	106	
LD	210	51.5	50	1.5	18.1	74	36	36	140	85	139	82	103	101	
MA	160	55.3	53.8	1.5	18.8	64	36.4	36.6	189	72	104	49	111	67	
WB	180	66.8	64.7	2.1	22.1	79	36.3	35.5	167	91	113	90	116	98	
Sodium															
id	Duration	Pre Wgt	Pst Wgt	UF Wgt	BMI	Pulse	T-pre	T-post	SBP-Pre	DBP-Pre	SBP-Post	DBP-Post	MAP-Pre	MAP-Post	
BD	196	69.3	66	3.3	19.7	83	35.1	35	170	72	108	46	105	67	
DT	194	78.2	75.2	3	24.8	67	35.7	35.9	230	100	152	72	143	99	
HC	180	75.2	73.6	1.6	27	98	35.7	36.5	149	79	152	66	102	95	
JM	240	65.2	63.2	2	20.9	55	36	35.6	160	69	117	60	99	79	
JoW	129	55.9	55.9	0	24.1	88	35.5	35.5	143	68	154	78	93	103	
LW	211	98.3	96.5	1.8	31.5	102	36.2	36.4	111	50	91	64	70	73	
PB	190	73.9	72.6	1.3	22.7	85	36.1	36	146	65	118	70	92	86	
Potassium															
id	Duration	Pre Wgt	Pst Wgt	UF Wgt	BMI	Pulse	T-pre	T-post	SBP-Pre	DBP-Pre	SBP-Post	DBP-Post	MAP-Pre	MAP-Post	
BD	196	69.8	66.7	3.1	19.9	72	35	36	187	70	148	68	109	95	
DT	235	77	74.7	2.3	24.7	66	35	36	205	98	97	65	134	76	
JoW	129	56.3	56.3	0	24.2	81	35	36.1	158	77	157	78	104	104	
LW	257	98.7	96.7	2	31.6	101	36.5	35.3	91	57	91	51	68	64	
PB	190	73.7	72.6	1.1	22.7	142	35.8	35.9	108	83	123	74	91	90	
TM	212	78.6	78.4	0.2	26.5	76	35.6	35.5	103	64	121	62	77	82	
JM	231	63.5	61.5	2	20.3	57	35.8	36	154	75	141	94	101	110	
Posture															
id	Duration	Pre Wgt	Pst Wgt	UF Wgt	BMI	Pulse	T-pre	T-post	SBP-Pre	DBP-Pre	SBP-Post	DBP-Post	MAP-Pre	MAP-Post	
CL	180	56.7	54.3	2.4	20.9	80	36.5	37	164	107	151	96	126	114	
DT	210	78.6	75.3	3.3	24.9	72	36.7	36.5	208	93	143	85	131	104	
PB	180	79.1	76.2	2.9	25.2	74	35	35.8	203	88	137	74	126	95	
TM	212	78.6	78.4	0.2	26.5	76	35.6	35.5	103	64	121	62	77	82	
TB	210	65.3	62.3	3	21.6	72	35.9	36.2	168	78	147	75	108	99	
Temperature															
id	Duration	Pre Wgt	Pst Wgt	UF Wgt	BMI	Pulse	T-pre	T-post	SBP-Pre	DBP-Pre	SBP-Post	DBP-Post	MAP-Pre	MAP-Post	
BD	196	67.7	66.5	1.2	19.9	85	35.2	35	135	52	160	59	80	93	
FK	180	66.4	64	2.4	20.2	105	35	36	132	96	111	66	108	81	
LW	212	100	97.3	2.7	31.8	90	36.2	36.7	100	63	101	58	75	72	
PB	190	74.1	72.9	1.2	22.8	68	35.9	36	126	70	135	81	89	99	
TB	210	65.1	61.6	3.5	21.3	76	36.2	36.3	176	77	139	70	110	93	

The MAP decreased significantly across all sessions post-dialysis. (102 ± 18 vs 90 ± 17 mm Hg, mean \pm SD, $p = 0.00058$). There was no significant difference between the pre- and post-dialysis temperatures.

6.3.3.3 Biochemical changes

There was no significant difference in the pre- and post-dialysis sodium concentrations (Table 6.3.6). As expected the serum potassium decreased significantly. However there seemed to be a slight rise in serum potassium in the first 30 minutes of dialysis in 3 patients that is difficult to explain and perhaps may be related to the assay times. (each labeled sample spun and then sent to pathology lab for immediate

analysis). The serum calcium tended to drop post-dialysis though this did not reach statistical significance ($p = 0.19$, paired t-test).

Table 6.3.6: Biochemical values (sodium, potassium, calcium) during dialysis in different sub-studies (all units are mmol/l)

Sodium

time	BD	DT	JoW	HC	JM	LW	PB
0	138	137	136	135	138	137	136
15	137	138		135	140	138	137
30	138	137	136	135		138	137
45	138	137	135	135	141	139	135
60	137	136	136	135	141	138	137
90	138	138	137	137	139	138	137
120	138	137		136	140	137	137
150	139	136		137	139	138	139
180				137		135	
end	139	136	137	135	140	138	137

Potassium

time	BD	DT	JBM	JoW	TM	LW	PB
0	5.4	5.3	5.5	4.7	5.2	4.9	7.2
15	4.9	5.6	5.4		4.6	5	5.9
30	5.5		4.8	4.5	4.5	4.8	6.3
45	5	4.3	4.4	4.1	4.3	4.8	
60	6	4	4.4	3.9	4.3	4.4	5.5
90	5	4	4.1	3.8	4.2	4.5	4.6
120	3.9	3.7	4.1			4.2	5
150	4.7	4.4	3.8			4.3	4.4
180			3.6				
end	4.5	5	3.7	4.1	4.1	4.1	4.1

Calcium

Time	AT	CL	DC	GH	JC	JBM	JW	LD	MA	WB
0	2.34	2.63	2.16	2.64	2.48	2.31	2.46	2.57	2.77	2.64
15	2.36	2.53	2.16	2.62	2.45	2.28	2.43	2.52	2.83	2.56
30	2.36	2.47	2.14	2.59	2.26	2.21	2.51	2.72	2.72	2.53
45	2.41	2.47	2.39	2.38	2.23	2.33	2.53	2.8	2.51	2.54
60	2.34	2.37	2.16	2.38	2.23	2.16	2.7	2.56	2.46	2.64
90	2.31		2.09	2.38	2.43	2.28		2.56	2.35	2.51
120			2.35	2.4		2.3		2.59		2.53
150			2.14	2.54		2.32		2.48		
180						2.3				
end	2.33	2.37	2.16	2.31	2.36	2.23	2.68	2.47	2.9	2.43

6.3.3.4 Bioimpedance profiles during changes in electrolyte composition:

6.3.3.4.1 Sodium (Na):

A typical RBV-ECF profile is illustrated below (Figure 6.3.1).

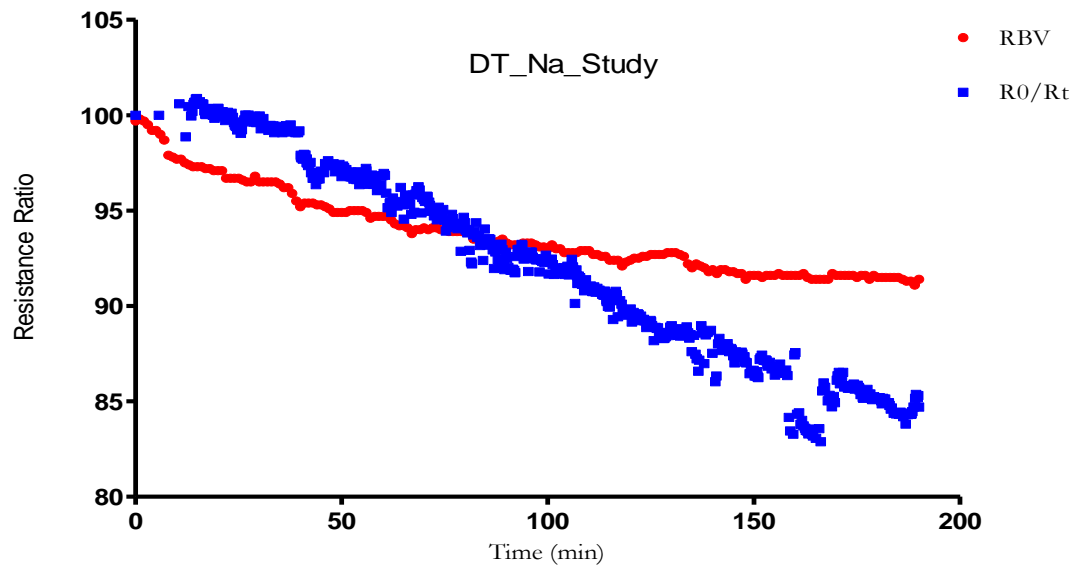

Figure 6.3.1: Changes in R_{ECF} and RBV during a dialysis session with alteration in dialysate sodium (see text for details)

Resistance Ratio fell during the dialysis session during all the studies due to UF and ECF compartment emptying. One subject (JoW) had no UF during dialysis. Three phases of change were expected over the first 90 minutes of dialysis with dialysate concentrations changing substantially from 146 to 130 to 138 mmol/L. There was no consistent pattern in the percentage change in R_{ECF} ratio during each phase nor were there differences between the groups with respect to this parameter. (Table 6.3.8). Figures 6.3.2, 6.3.3, 6.3.4 depict the actual traces in a typical patient.

Table 6.3.8: Change in Resistance ratio during different phases (%)

ID	Change_Na146	Change_Na130	Change_Na138
BD	-7.30	-1.87	-3.10
DT	-0.20	-2.92	-5.20
HC	-4.50	-1.20	-2.73
JBM	-4.50	-5.80	-2.80
JoW	2.00	2.00	0.96
LW	-4.86	-5.47	
PB	-5.13	-5.58	-10.95

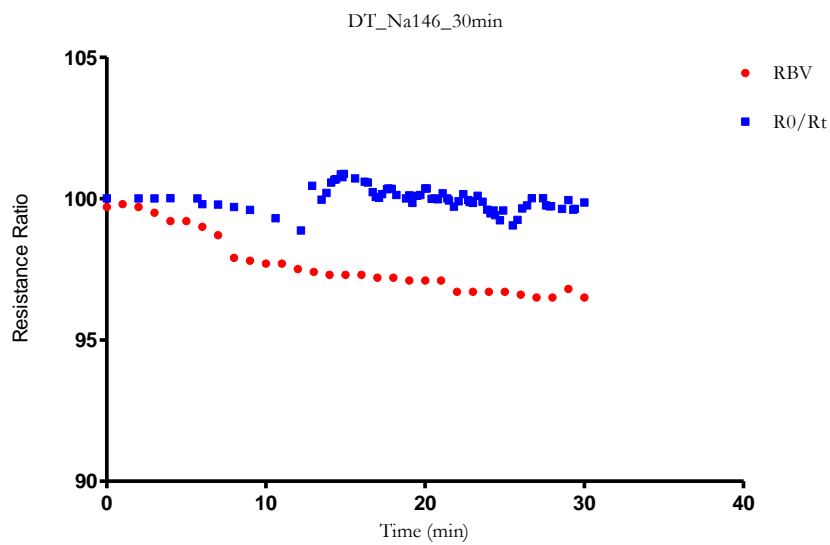

Figure 6.3.2: Profile during the dialysis period using a Dialysate Na of 146 (Generated using Prism v5.0)

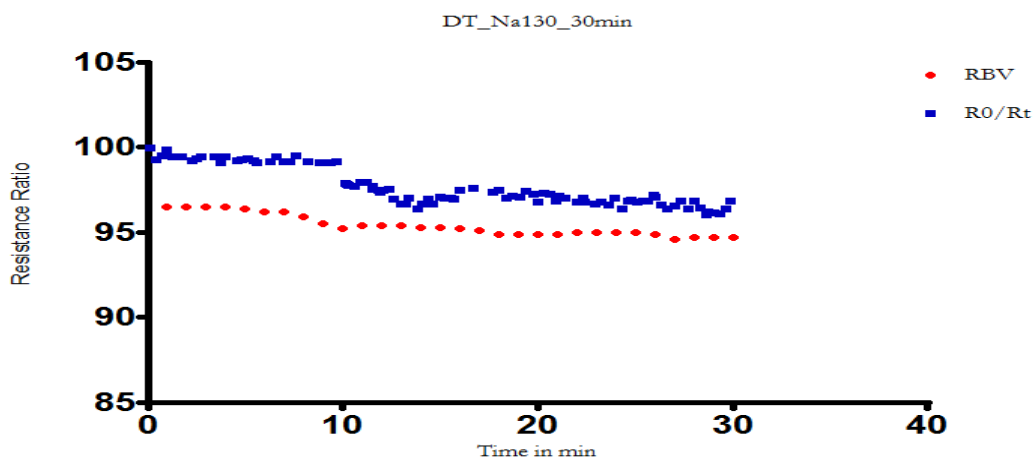

Figure 6.3.3: Profile during the dialysis period using a Na of 130 (Generated using Prism v5.0)

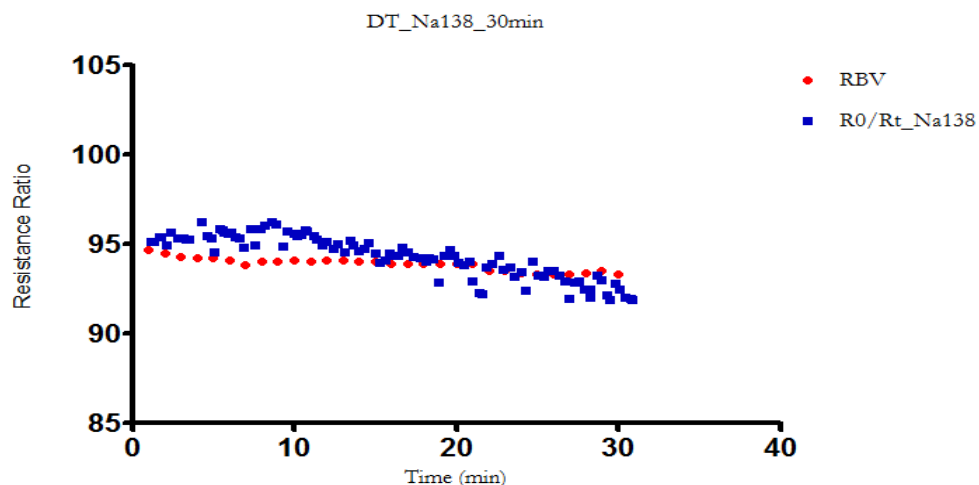

Figure 6.3.4: Profile generated during dialysis period with dialysate Na 138 (Prism)

When the changes in R_{ECF} ratio were analysed for shorter intervals towards the end of each intervention – to minimise any crossover effects from previous condition (time segments between 20-30 minutes with Na at 146 vs between 50-60 minutes at Na 130 vs between 80-90 minutes at Na 138), the slope of the ratio remained indistinguishable between the three interventions. (Table 6.3.9 and Figure 6.3.5). The difference in absolute values relate to the stage of dialysis and to the cumulative volume of ultrafiltration which has been carried out to that point.

Table 6.3.9: Composite Resistance Ratio change of all 7 patients plotted at 1 minute intervals for each intervention

Time	Mean-146	Mean-130	Mean-138
1	97.77	92.86	89.01
2	97.11	92.84	89.56
3	96.88	92.82	89.28
4	96.87	92.07	88.89
5	96.87	92.39	88.86
6	96.99	92.08	88.54
7	96.69	92.42	88.39
8	96.56	92.60	89.35
9	96.50	92.47	88.86
10	96.09	92.25	88.44

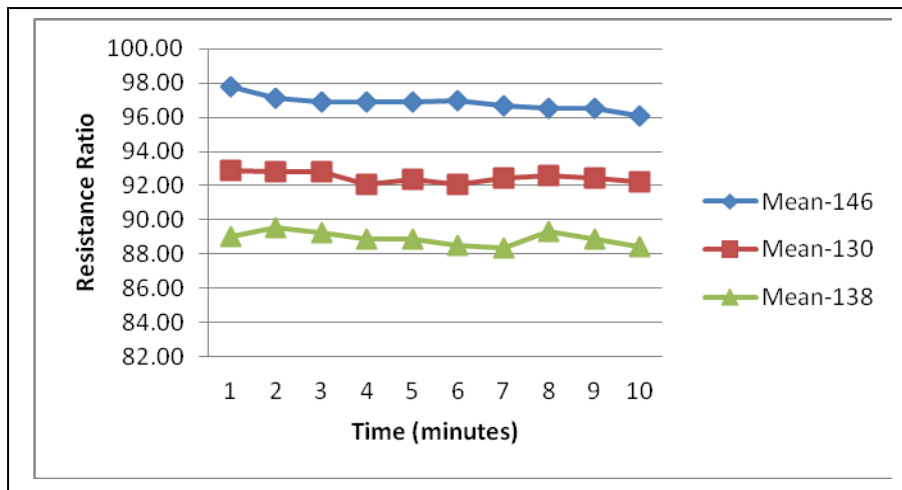

Figure 6.3.5: Composite Resistance ratios of all 7 patients during terminal 10 minute phase of each sodium concentration

Plotting Resistance Ratios of all 7 patients illustrates the differences in decay between patients and also within patients over time indicative of ECF compartment emptying and progressively reduced vascular refill rates (Figure 6.3.6).

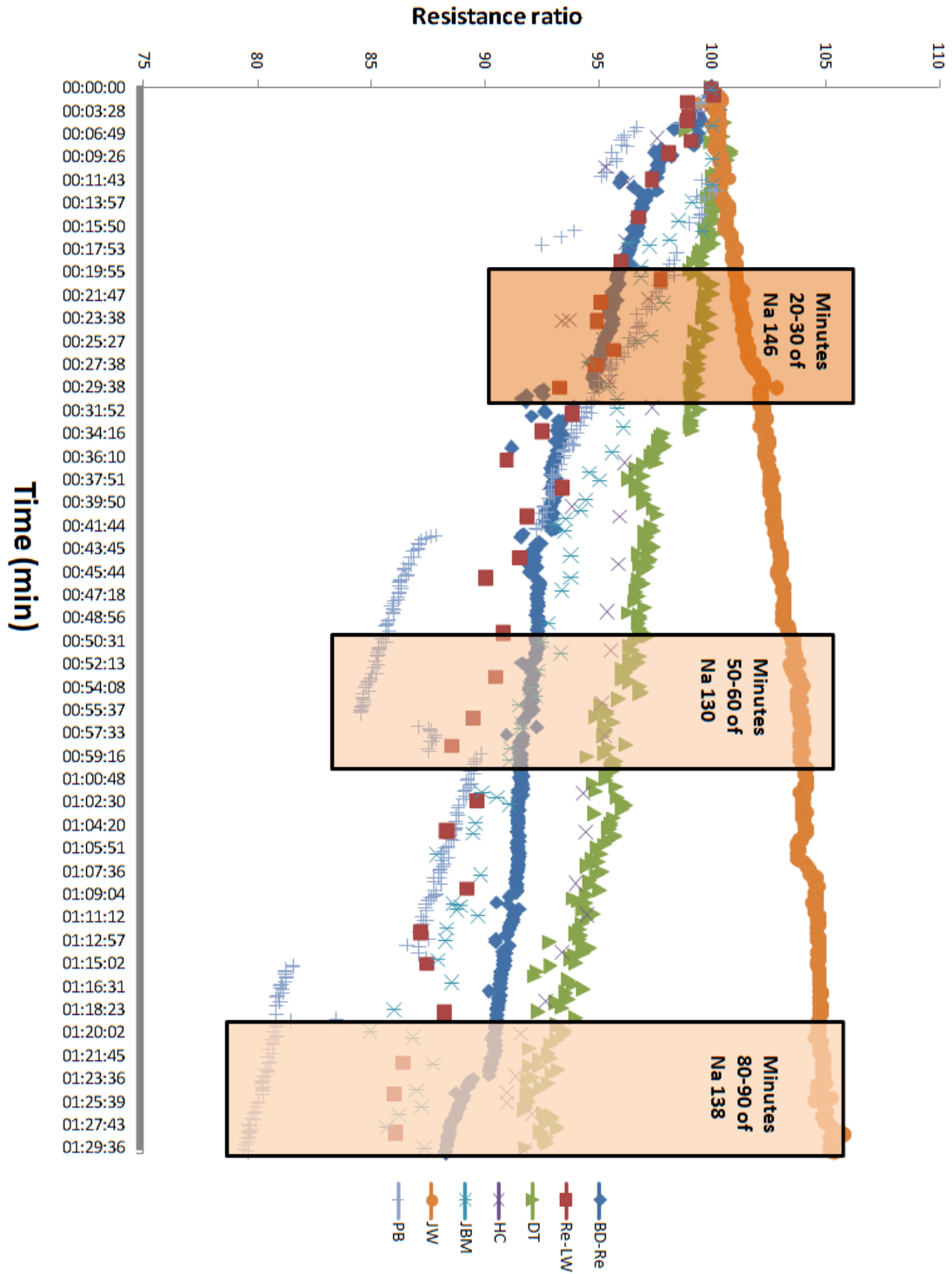

Figure 6.3.6: Changes in Resistance Ratio in the first 90 minutes of dialysis. Highlighted portions were analysed further.

Further refinement by analysing changes during even shorter time segments was attempted. Slopes of Resistance Ratio were compared for 5 minutes towards the end of Na₁₄₆, Na₁₃₀ and Na₁₃₈. (Table 6.3.10) The assumption was that the effect of UF would be minimal during such short periods and if there was an ongoing change in compartment volumes consequent to change in Na this will be borne out by a change in slope between the three phases. The slopes were not significantly different. (Figure 6.3.7 and table 6.3.10)

Table 6.3.10. Results of ANOVA comparison of slopes over 5 minute periods during dialysis at different dialysate sodium concentrations.

Condition	Slope	P value
Sodium 146 mmol/l	-0.297	
Sodium 130 mmol/l	-0.191	
Sodium 138 mmol/l	-0.166	P= NS

Comparison of slope obtained using different sodium concentrations

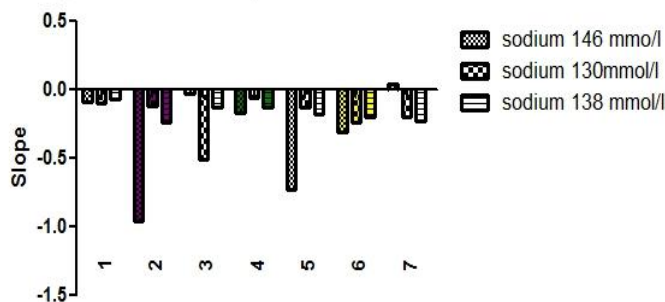

Figure 6.3.8: Comparison of slopes over 5 minute periods during dialysis at different dialysate sodium concentrations

6.3.3.4.2 Effects of Calcium and Potassium:

Serum calcium and potassium alterations were studied in 10 and 6 patients respectively. As before the slopes of Resistance Ratio change were not significantly different (Figure 6.3.9), using the same methodology of plotting slopes for 5 minute segments as one intervention gave way to another.

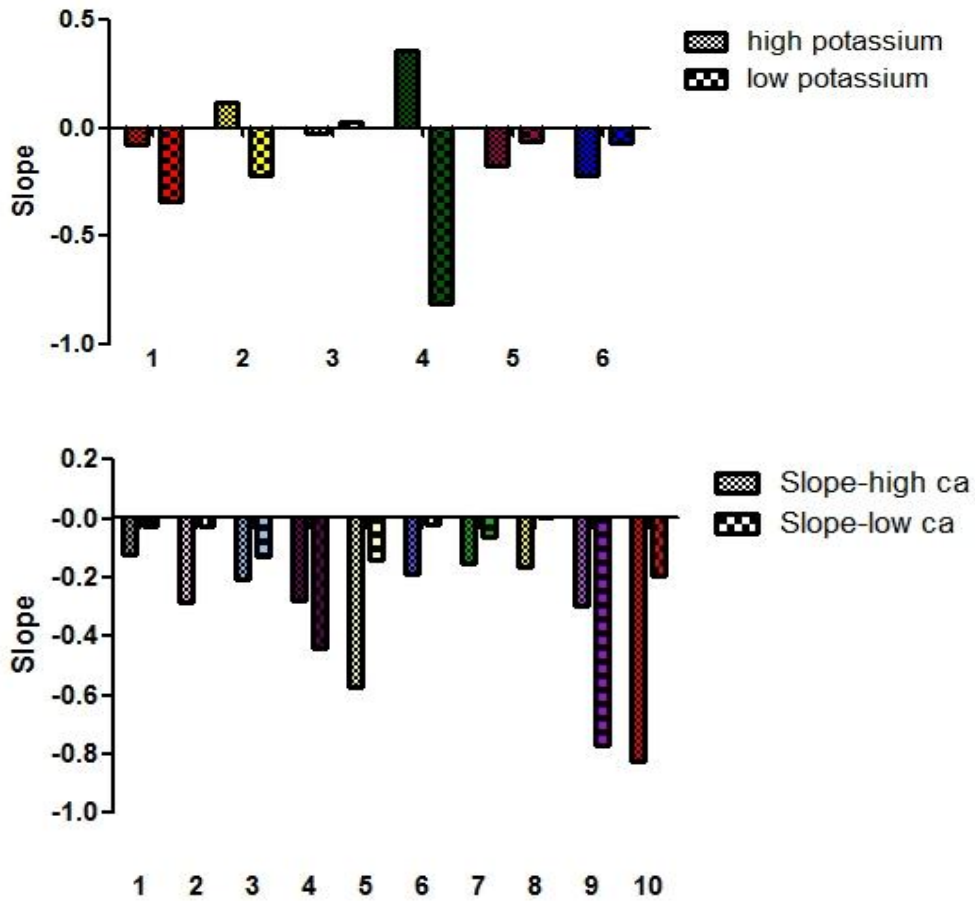

Figure 6.3.9: Comparison of slopes for dialysate Ca and K interventions (high K is 3 and low K 2 mmol/L; high Ca is 1.75 and low Ca 1.25 mmol/L)

6.3.3.4.3 Temperature and posture:

There were no differences in the slopes obtained during changes in response to either of these interventions (Figure 6.3.9)

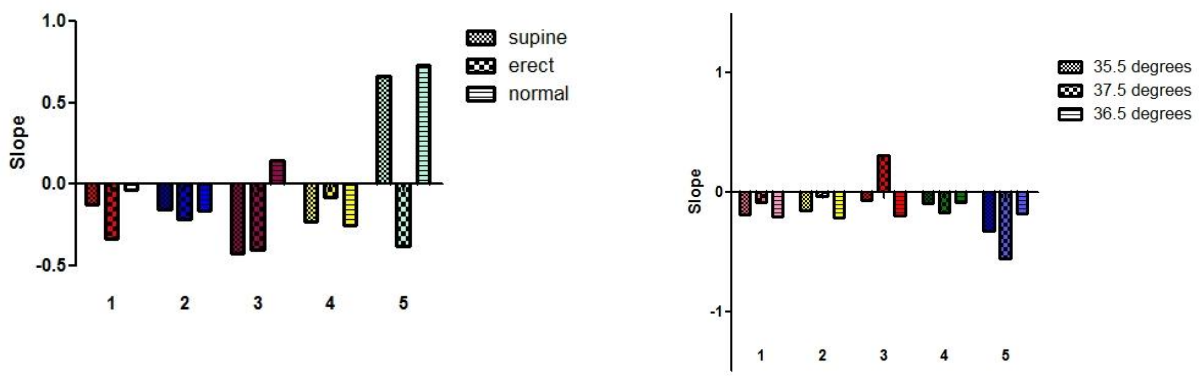

Figure 6.3.9: Comparison of slopes for different postures and temperatures

6.3.3.4.4. Isovolemic HD

Complete data sets were available from 8 patients. There was a variable decline in Resistance Ratio in all the 8 patients studied even though there was no UF being carried out during the first hour. The decrease was negligible in 2/8; (0 and 2%), 3.7% in the third and between 8-11% in the rest. The mean change was 7.5%. All patients assumed a semi-recumbent position during dialysis. Haemodynamic variables remained unchanged during the isovolemic session. Subject AK did not have any UF throughout dialysis and subjects MM, CL < 1L. The percentage changes in the R_{ECF} and RBV are summarised below.

Table 6.3.11: Changes in monitored variables during one hour of isovolaemic dialysis – Delta R-ECF-1 hour = change in ECF resistance during one hour of isovolaemic ultrafiltration. Delta R-ECF-full*= change in ECF resistance during whole session. Td = duration of dialysis. RBV = relative blood volume. UFV = ultrafiltration volume during remainder of session

ID	AK	CL	CT	EA ^D	MM ^D	NB	SB	VS
Delta R-ECF-1 hour*	2.0	0	13.0	3.7	11.5	10.2	11.7	8.0
Delta R-ECF-full*	4.4	11.6	25.9	12.6	25.3	22.5	25.2	20.7
Td	200	180	195	210	165	180	165	180
UFV	0	800	1200	1800	800	1800	1300	2100
RBV fall -1 hour	2	0.9	0.1	2.8	0.1	+6	0.3	5.4
RBV fall - full	1.1	2	6	9.9	6.2	1.8	11	19.7

6.3.3.4.5 Intra-subject variability of bioimpedance profiles

Data from three patients each over 10 consecutive sessions was analysed. Dual compartment monitoring was carried out without any changes to the dry weights. The UF volumes and mean ultrafiltration rate for each of the dialysis sessions is as shown below in Table 6.3.12

Table 6.3.12. Ultrafiltration volumes (UF), and mean ultrafiltration rates (ml/kg/hr) in 3 patients studied by dual compartment monitoring over 10 successive dialysis sessions.

Study	AH		BD		TB	
	UF	ml/kg/hr	UF	ml/kg/hr	UF	ml/kg/hr
1	2400	8	1900	10	3500	16
2	1900	7	1500	8	3160	14
3	4600	16	1500	8	2300	11
4	3000	11	1500	8	3500	16
5	2000	7	2500	13	3400	16
6	900	3	1300	7	2400	11
7	2300	8	1800	9	3500	16
8	1800	6	2100	11	2500	11
9	2400	8	2000	11	3300	15
10	2900	10	2000	11	3500	16

The Resistance Ratio was analysed for each patient for each session. There was considerable intra-patient variability. (Figure 6.3.10)

The UF normalised to the post-dialysis weight was similar in subjects AH and BD. Subject TB had significant IDWGs. TB and BD were diabetic.

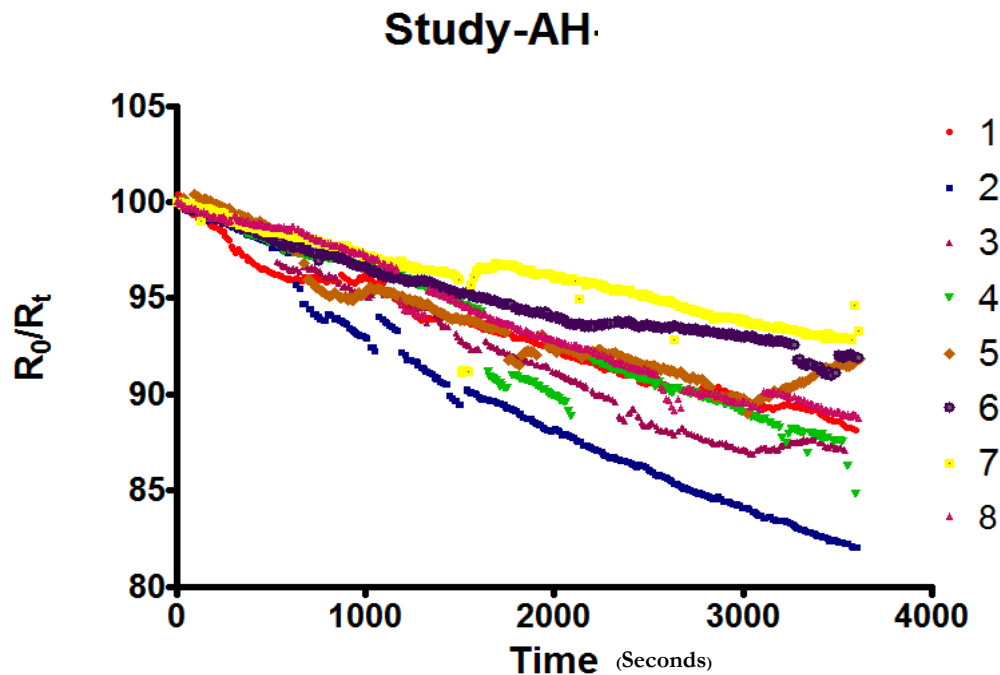

Study-BD

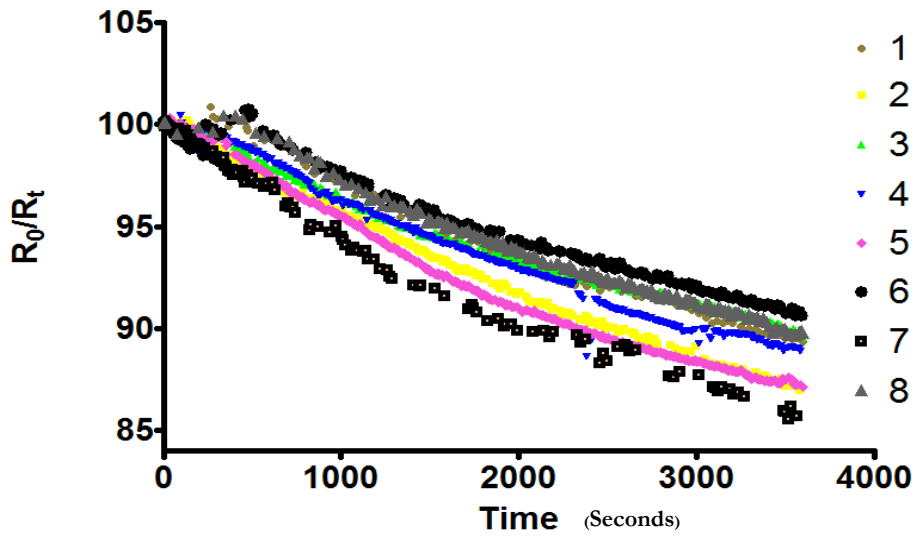

Study-TB

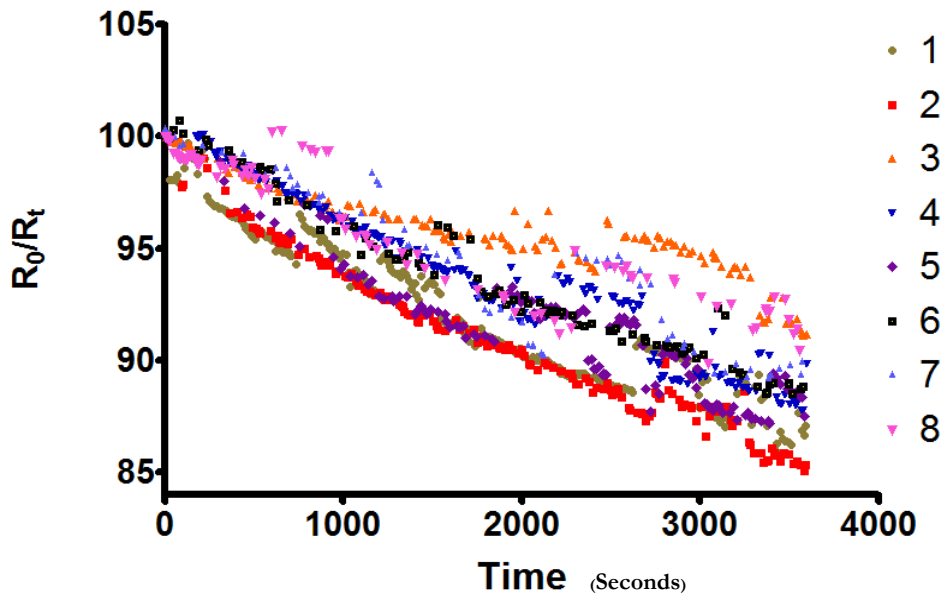

Figure 6.3.10:

Resistance ratio during first 60 minutes of dialysis with UF in 3 patients over 10 successive sessions

In spite of significant variations in IDWG, the first 60 minutes of 8/10 sessions in 2 patients and 9/10 the third, could be modelled as a one phase exponential decay (Table 6.3.12). The goodness of fit (R^2) was 0.9 (range 0.855 to 0.998 across the 25 sessions). In one phase decay equations, the half life, time constant and the rate constant predict the change in Y (in this case the Resistance Ratio) as X (time) progresses (Figure 6.3.11) . The equation takes the exponential form as given below.

$$Y = (Y_0 - \text{Plateau}) * e^{(-K \cdot X)} + \text{Plateau}$$

where Y_0 is the 'Y' value when 'X' (time) is zero, 'Plateau' is the Y value at infinite times, 'K' is the rate constant, tau (τ) is the time constant, half life is in the time units of 'X'. This is computed as $\log_2 \frac{2}{K}$ (illustrated in Figure 6.3.11)

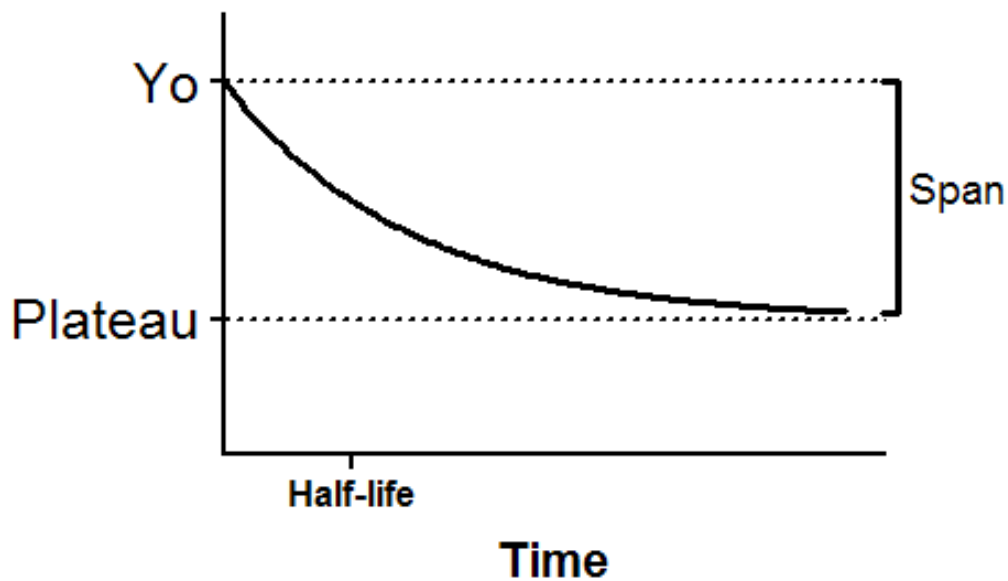

Figure 6.3.11 : Characteristics of first order decay

Table 6.3.12. Results of curve fitting in 25 sessions in 3 patients in which decay of Resistance ratio fitted first order kinetics.

Study-AH-Eight									
Y0	99.17	100.8	100.5	100.4	101.4	100	99.59	100.6	
Plateau	80.03	72.95	76	68.01	89.03	89.31	76.73	74.97	
* K	227	307	246	147	649	383.6	94.77	180	
Half Life	3053	2256	2820	4710	1068	1807	7314	3858	
Tau	4404	3255	4069	6795	1540	2607	10551	5566	
R ²	0.9866	0.9942	0.9869	0.9487	0.9609	0.9866	0.909	0.9799	
Study-BD-Eight									
Y0	101.4	100.3	100.5	100.6	100.9	100.2	100.3	101.2	
Plateau	80.19	75.03	85.04	78.56	81.45	59.9	80.69	78.55	
* K	233	207	315	218	347	764.3	358.2	197	
Half Life	2981	3347	2202	3178	1997	9070	1935	3522	
Tau	4300	4829	3177	4584	2881	13085	2792	5082	
Span	21.17	25.3	15.5	22.08	19.45	40.33	19.57	22.62	
R ²	0.9894	0.998	0.9972	0.9918	0.9976	0.9791	0.9962	0.9909	
Study-TB-Eight									
Y0	98.94	99.08	99.56	100.5	99.23	100.5	100.5	100.5	100
Plateau	82.93	79.52	89.51	74.04	83.3	90	80.52	77.07	88.8
* K	354	307	279	172	330	520.6	244.5	177	389
Half Life	1959	2259	2488	4042	2100	1331	2835	3924	1781
Tau	2827	3259	3590	5831	3030	1921	4090	5661	2569
Span	16.01	19.56	10.05	26.44	15.92	10.45	20.03	23.4	11.2
R ²	0.9354	0.98	0.8745	0.9573	0.8577	0.9125	0.9705	0.8553	0.87

The correlation between UF rate and the rate constant ‘K’ was 0.83 (Pearson’s correlation coefficient). This can be taken to indicate, that a large proportion of the intra-patient variability is related to differences in ultrafiltration rate.

6.3.3.4.6 Variations in R_{ECF}

The variations in the R_{ECF} over three sessions were studied in twelve subjects. There was a wide variation in initial R_{ECF} values in the same patient. The percentage variation from the lowest to the highest value ranged from 6.4 to 47.8%. (mean percentage change $23.8 \pm 12.6\%$) There were significant differences between the high, mid and low values. ($p = 0.002$ and $p < 0.001$ respectively). However there were no significant differences between these groups with respect to the interdialytic weight gain. (Table 6.3.13).

Table 6.3.13

R_{ECF} values in 12 subjects:

High refers to the highest of the three values obtained, Low the lowest of the three values and Mid the middle value. UF1, UF2 and UF3 are the corresponding UF volumes.

Pt id	High	UF1	Mid	UF2	Low	UF3
AH	50.15	2300	46.5	1700	34.67	2100
AM	56.94	2300	52.19	2300	45.86	3800
BD	70.3	2800	60.94	700	47.58	1500
CA	72.94	500	70.59	500	62.98	400
DK	44.48	0	42.49	900	36.88	1600
JF	38.6	3400	36.73	3200	30.88	2700
LP	52	1000	51.74	400	44.06	400
MHA	59.48	3100	58.12	3000	50.73	2000
ME	54.05	400	51.94	900	50.79	1600
SG	44.76	3800	43.66	3100	37.75	2700
TD	56.35	1200	54.87	3000	50.15	2200
VS	82.51	1700	76.53	2100	60.96	1900

Table 6.3.14 Lack of association between R_{ECF} at the start of dialysis and the corresponding UF for that session, there were significant differences between High, Mid and Low R_{ECF} values but not UF1, UF2 and UF3

	N	Mean	Std. Deviation
High	12	56.9	12.8
Mid	12	*53.9	11.5
Low	12	**46.1	9.9
UF1	12	1875	1264
UF2	12	1817	1102
UF3	12	1908	947

* High v Mid: p = 0.002
 **Mid v Low: p <0.001
 Significant difference between High, Mid and Low R_{ECF} values but not UF1, UF2 and UF3

The variations in the resistance (R_{ECF}) values in Subject BD and the corresponding resistance ratio – $\frac{R_0}{R_t}$ for subject BD is illustrated.

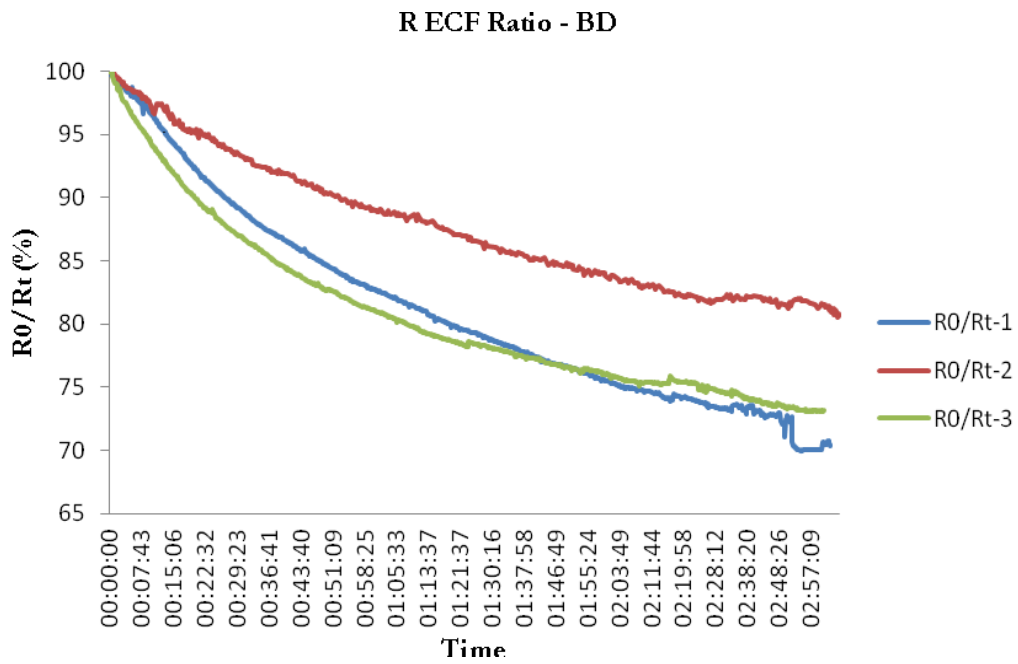
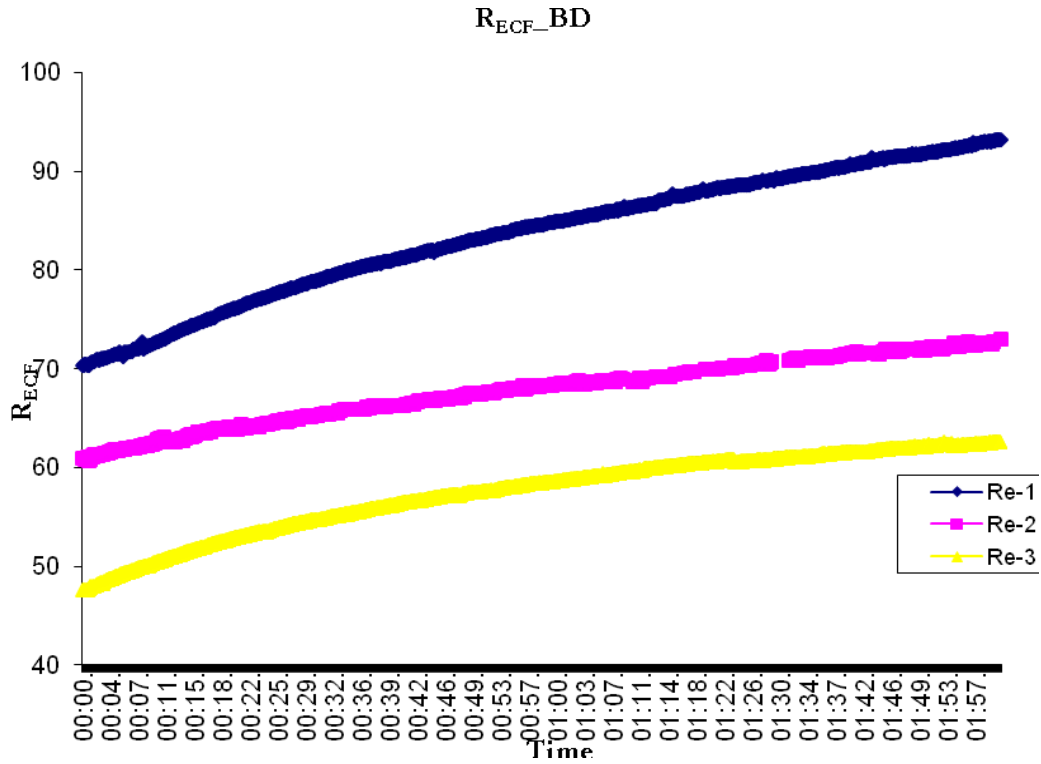

Figure 6.3.12

Variation in the start R_{ECF} of Subject BD on the top panel and the corresponding change as a ratio for the three sessions. There is a comparable decay of the ECF volume across the three sessions even though absolute values are different

6.3.4 Discussion:

These series of studies have evaluated CSBIS technique for its applicability as a volume management tool. The most important parameter determining the nature of the R_{ECF} profile is the ultrafiltration rate. The ultrafiltration rate and the vascular rate refill offset each other during the early phases of dialysis to preserve intravascular volume and prevent IDH. An estimate of this refill can be reliably gleaned in real time by the CSBIS technique, particularly in association with RBV monitoring.

The technique seems to be uninfluenced by electrolyte changes in the plasma and ECF during dialysis. This is clear for dialysate potassium and calcium, but the effects of a changing dialysate sodium are more complex. In this study though, there were no observable effects of changes in dialysate sodium which could not be explained by the osmotic effect of sodium, overridden by continued ultrafiltration. Use of changing dialysate conductivities during isovolemic dialysis may have provided a better basis to unpick investigate any possible effects. Such an approach was impracticable since most patients require significant ultrafiltration to avoid positive sodium balance.

The results of the 8 studies during isovolaemic dialysis were particularly intriguing. In spite of the absence of ultrafiltration R_{ECF} in fell in most patients by mean of 7.5% during the first hour. It is important to address the issue of whether this is an artefact of the technique or whether this represents a genuine fluid shift. Whilst acknowledging the need for more work to clarify the issue, I think that there is a fair probability that considerable fluid shifts do occur in this phase of dialysis even in the absence of ultrafiltration.

There may be a number of possible explanations. Firstly, considerable urea disequilibrium is generated in the first part of the dialysis session, resulting in a fluid shift from the extracellular fluid into the cells. Secondly, at the commencement of dialysis patients assume a semi recumbent position. This may result in shifts from the ECF to the central circulation. We found no obvious short-term effects of changing posture on Relative resistance slope in 5 patients studied elsewhere in this chapter, though it may be that a longer observation time is required. This effect may also be amplified by the prescription of vasoactive drugs, which are often associated with interstitial oedema of the lower limbs, which is mobilised when the

patient becomes recumbent. It is interesting that patient NB showed a fall in Resistance ratio at the same time as showing an increase in RBV suggesting a central fluid shift, and that this patient was on two vasodilating antihypertensive agents. It may also be that non-renal co-morbidities eg diabetic autonomic neuropathy may also contribute and two of these patients were diabetic. Zhu et al in comparing WBIA with SSBIS, noted an increase in trunk volume with a decrease in limb volume detected by SSBIS but not by WBIA[333]. Monitoring a single segment would tend to amplify the impression of volume loss. Thirdly, a negative sodium gradient between dialysate and plasma would result in sodium removal and ECF contraction even in the absence of ultrafiltration. We did not measure plasma sodium in this group of patients but it is unlikely that this explanation would account for this finding in most of these patients. The finding of ECF volume contraction in the absence of ultrafiltration is clearly a very interesting phenomenon and requires further investigation.

When R_{ECF} changes are tracked in a way similar to RBV monitoring (without the UF pulses or perturbation dialysis), over multiple dialysis sessions in a single patient, the profiles are very similar to that obtained from RBV monitoring. There is variability in the decay within a patient governed primarily by the ultrafiltration requirements per session. These changes assume an exponential pattern of decay, at least in the initial third of a dialysis session, and obtained consistently over a period of time, can potentially become the vascular refill 'blue print' for the patient. This can then be used to define the onset of change from an exponential to linear decay as dialysis progresses that then can be used as a marker for proximity to dry weight. When this data is transposed onto the RBV, a powerful dual compartment monitoring tool emerges, that is relatively easy to deploy at the bedside.

When subjects were studied repeatedly, it is apparent that the R_{ECF} at the start of the sessions differs significantly from session to session. This may be because of the tendency for small volume changes in the leg segment to be amplified by the CSBIS technique. Furthermore fluid shifts as subjects assume a recumbent position at the start of dialysis can cause changes in the measured R_{ECF} at the start, these shifts may occur at varying rates within the same subject and determined only partly by the inter-dialytic weight gain (IDWG). The whole body technique will mask such changes as the whole body is considered as a cylinder with shifts within individual segments offsetting each other. These features provide CSBIS

with a major advantage for tracking intradialytic changes in the R_{ECF} but prevent valid direct comparisons of absolute values of R_{ECF} between dialysis sessions even in the same patient. Employing a ratio of change rather than the absolute value shows predictable patterns of decay and accurate judgement of compartmental emptying towards the end of dialysis.

In conclusion, the CSBIS technique has been shown to be easily applicable, probably immune to ionic shifts and representative of the vascular refill response to UF during dialysis. The utility of these dynamic changes tracked in real time as a useful non-invasive tool for volume management will be further investigated in later sections of this thesis.

Chapter 6.4

Quantification of vascular refill using combined CSBA-RBV monitoring in Haemodialysis Patients.

Assessment of Utility in Assessment of Target Weight

6.4.1 Introduction

Cardiovascular disease is the leading cause of mortality in the dialysis population

[588-596]. Pre-existing cardiac disease and hypertension, volume overload at initiation and throughout dialysis career, hypotensive episodes on altered calcium-phosphate metabolism, lipid abnormalities related to uraemia, hyperhomocysteinuria, increased levels of concentrations of agents which promote vasoconstriction, such as asymmetrical dimethylarginine (ADMA) and ouabain like peptides, and nocturnal hypoxemia[597], may all contribute. Management of volume status is a major concern in our attempts to reduce cardiovascular morbidity and mortality in these patients. The aim of this is to reduce the prevalence of both interdialytic hypertension and intradialytic hypotension. Achievement of this requires frequent clinical assessment of patients on dialysis aided and abetted by the use of bed side techniques. Online blood volume monitoring and bioimpedance analysis are among the simpler techniques available for this purpose. The theoretical and practical aspects of these tools have been extensively discussed in earlier chapters.

The aim of this study was to evaluate dual compartment monitoring -a combination of CSBA and RBV monitoring, to track ECF and intravascular volume changes during dialysis. CSBA was used to measure changes in the ECF compartment while simultaneous RBV monitoring tracked the intravascular volume change. The combined monitoring was used to quantify vascular refill with reference to the Refill Ratio parameter previously described in chapter 6.2.

6.4.2 Subjects and Methods

6.4.2.1 Subjects

Twenty-nine patients were studied (23 Males, mean age 62 ± 13 years). All were receiving thrice weekly high-flux haemodialysis, the characteristics of which have been described in chapters 5 and 6.1. All had definitive vascular access. (Arteriovenous fistula, AVF). There had been no episodes of dialysis-related hypotension over the preceding six weeks. None of the patients had peripheral oedema and were all dialysing to a set dry weight. Haemoglobin was maintained as per the guidelines with the use of ESA (erythropoiesis stimulatory agents). None of the patients had refractory hypertension. None was receiving

more than two antihypertensive agents. None of the patients had clinical evidence of overt cardiac disease in the study group. Fourteen patients were active on the transplant waiting list. Eight were being worked up for activation at the time of this study. Two had neoplasms for which they had undergone surgery (Nephrectomy and resection of bladder tumour). Three subjects had non-occlusive disease of their coronary arteries that were deemed high risk by the Transplanting centre to be placed on the deceased donor waiting list. Two studied subjects were not on the transplant list taking into account their age.

6.4.2.2 Data Collection

Data on the following parameters was collected:

- Pre and post-dialysis weight
- Pre- and post-dialysis mean arterial blood pressures (MAP)
- Intradialytic MAP, length of dialysis session
- Time on dialysis (vintage)

6.4.2.3 Techniques

The investigator used following techniques as described in the previous chapter:

1. The in-built BP module of the Fresenius Dialysis Delivery System was used to record MAP.
2. The Hydra ECF/ICF Model 4200 (Xitron-Tech, San Diego, USA) was used for multifrequency BIA was used to measure ECF resistance (R_{ECF})
3. CSBA was obtained from a 10 cm segment of the lower leg also as describe in the previous chapter. Data was collected continuously by connecting the Hydra 4200 to a Personal Computer laptop through a serial port.
4. The built-in Fresenius BVM module was used to record RBV data.

5. Data management was carried using the Finesse system and a personal laptop computer

6.4.2.4 Dialysis and Ultrafiltration Prescription

6.4.2.4.1 Dialysis prescription

High flux dialysis was carried out as described in Chapters 2 and 6.1 with an average blood pump speed of 300ml/min (range 250ml/min to 350ml/min).

6.4.2.4.2 Ultrafiltration prescription

Ultrafiltration was carried as follows. The dialysis session was divided into seven unequal time segments. (Fig 6.4.1) Briefly, this comprised sequentially of:

1. 5 minutes of isovolemic dialysis (HD_{iso}) at the start of the session
2. 15 minutes of rapid UF (I Pulse, 15% of the IDWG)
3. 10 minutes of HD_{iso} (I Rebound, R1),
4. Phase of constant UF (70% of IDWG) – for [td - 65]mins
5. 10 minutes of HD_{iso} ,
6. 15 minutes of rapid UF (II Pulse, 15% of IDWG) - commencing 25 minutes before the planned end of the session
7. 10 minutes of HD_{iso} (II Rebound, R2) - for the final 10 minutes of the session

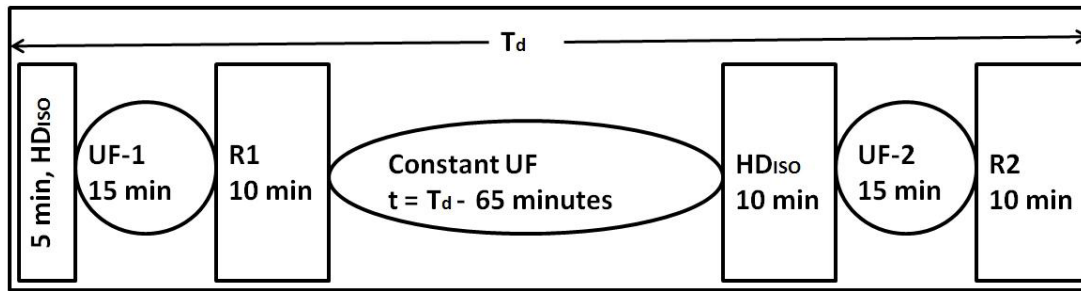

Figure 6.4.1: Cartoon representing modified HD session

T_d : Dialysis duration, t : duration of specified segment

6.4.2.4.3 Repeat Studies

Dry weight was reduced in subjects thought to be fluid overloaded based on the first CSBA-RBV profile, and the patients were restudied.

6.4.2.5 Data Analysis

Student's paired *t test* was used to ascertain the significance of differences between CSBA-RBV profiles for the R1 and R2 phase, and the means of paired RR values for R2 within patients obtained from dialysis sessions pre and post-dry weight reductions. Statistical package used was Graph Pad Prism v4.1 (Graph Pad Software, San Diego, CA, USA). Microsoft Excel 2003 (Microsoft Corp, USA) was used to graphically represent combined RBV-CSBA data. RR was then calculated by analysing the specific CSBA-RBV data pertaining to R1 and R2 phases.

6.4.2.6 Refill Ratio (RR)

RR is an arbitrary parameter developed by the investigator to compare vascular refill of R1 and R2 for a single dialysis session and R2 for successive dialysis sessions within the same patient with different post-dialysis weights. The method of calculation of RR from CSBA-RBV curves was described in the previous chapter (6.2). Figure 6.4.2 represents the CSBA and the RBV curves throughout the whole dialysis session in a single patient. The image shows the two 10 minute rebound periods R1 and R2 following 15 minute periods during which ultrafiltration at high rate was carried out (15% of ultrafiltration requirement

over 15 minute period). A value of near unity is taken to be indicative of a post-dialysis volume state close to euvolemia or cessation of vascular refill

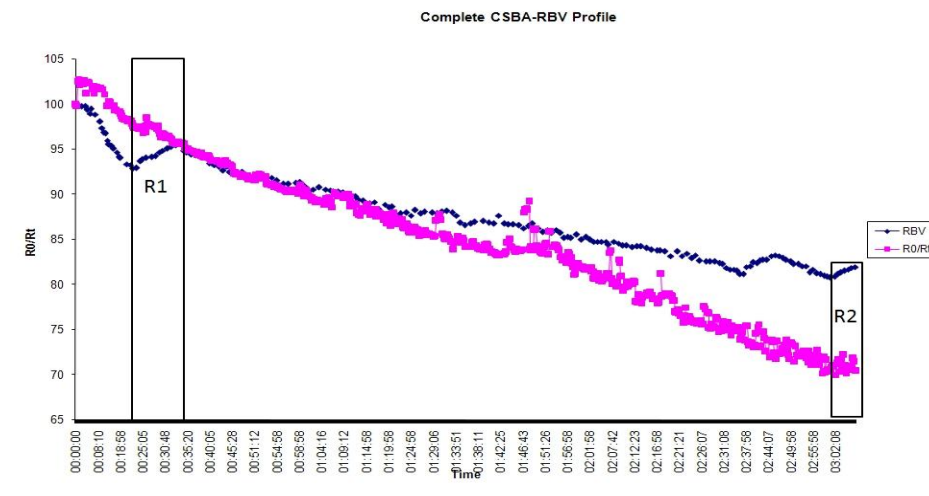

Figure 6.4.2: A complete CSBA-RBV profile: R1 is the first rebound phase (HD_{iso}), R2 second rebound phase, Y-axis represents R_0/R_t which is the ratio of R_{ECF} at time 0 (start of dialysis) to time t, X-axis represents absolute time

Figure 6.4.3 shows the first rebound period in more detail. The R_0/R_t value has been adjusted to 100% by re-calculating R_{ECF} ratio at the start of R1. A1 represents the difference between the R_0/R_t value and RBV values at the start of the R1 period and B1 represents a similar value the end of R1. The Refill Ratio (RR1) is $A1/B1$. Larger the RBV rebound higher will be the Refill Ratio.

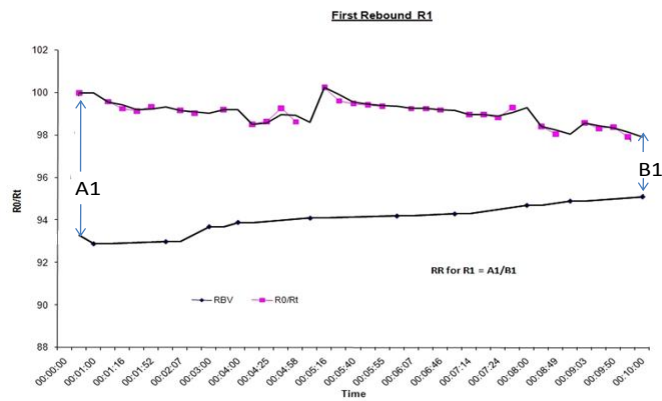

Fig 6.4.3: Concept of Refill Ratio (RR) ($A1/B1$). $A1$ is the difference between R_0/R_t and RBV values at the start of $R1$, the R_0/R_t value having been adjusted to 100 % at start of $R1$. $B1$ represents a similar value at the end of $R1$.

Figure 6.4.4 shows the second rebound in more detail, again with the R_0/R_t value has been adjusted to 100% by re-calculating R_{ECF} ratio at the start of $R2$. $A2$ represents the difference between the R_0/R_t value and RBV values at the start of the $R2$ period and $B2$ represents a similar value the end of $R1$. The Refill Ratio ($RR2$) is $A2/B2$. It is obvious from these illustrations that $RR1 > RR2$, and that $RR2$ approximates unity, implying a closer proximity to target weight, in the second rebound period.

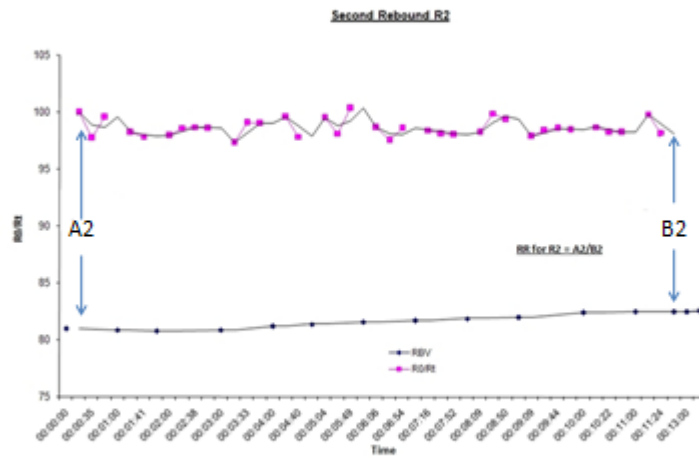

Figure 6.4.4: Refill ratio (A2/B2) during second rebound period (RR2).

Towards the end of dialysis RBV rebound will be minimal or absent in patients closer to their true dry weights. The ratio therefore will tend towards unity. An interpretation of cessation of refill can also be made if there are suspected factors like autonomic neuropathy preventing fluid shift from ECF to the intravascular compartment. In this situation, hypervolemia may exist.

6.4.4 Results

The details of the study group are summarised. (Table 6.4.1).

Table 6.4.1 Characteristics of the 29 studied patients

Parameter (n=29)	
Age	63±13
Weight (kg)	71.5±13
Td (min)	195±25
Duration (months)	77±67
UF volume (ml)	2100±600

Twenty-nine patients were studied at baseline. In 21 of these a reduction in dry weight was achieved and the patients were restudied.

In the 29 baseline studies, when the Refill Ratios at the end of the dialysis session (RR2) were compared with those of the same patient at the beginning of the same session (RR1), major differences were apparent (Figure 6.4.5). RR2 was significantly lower than RR1 in all 29 sessions (4.2 ± 3.7 vs 1.4 ± 0.5 ; mean \pm SD; $p = 0.001$).

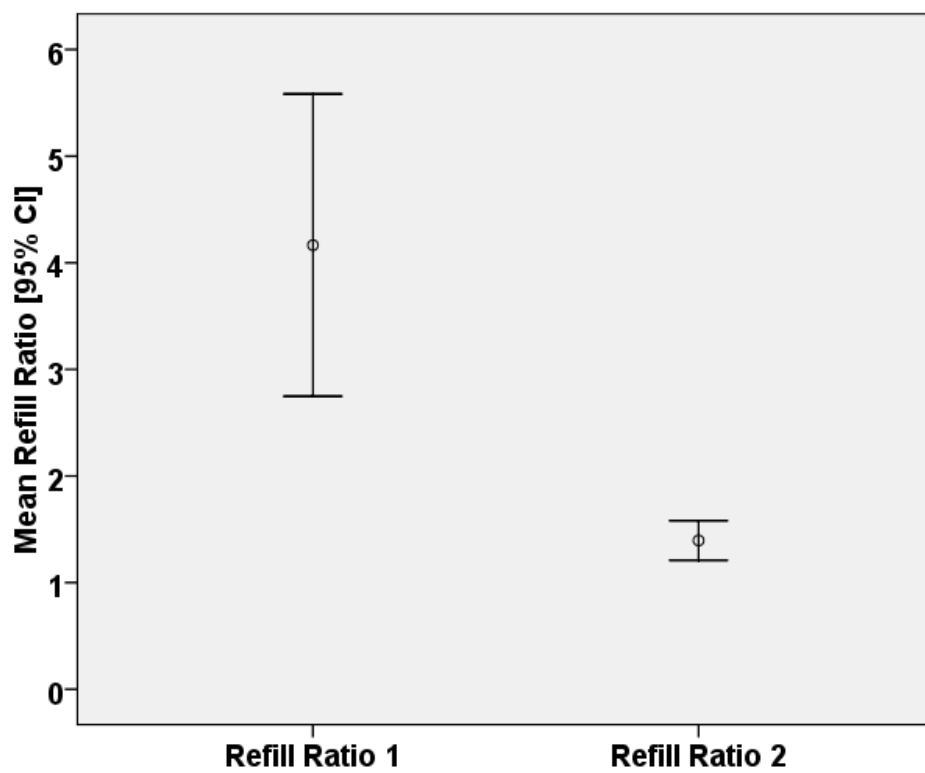

Figure 6.4.5: Comparison of Refill Ratio for Rebound phase 1 (RR1) and rebound phase 2 (RR2) phases in 29 patients at baseline ($p = 0.001$)

In the 21 patients (Table 6.4.2) in whom dry-weight reduction was achieved, the final Refill Ratio for the repeat session [at the lower weight] was significantly less than that for the baseline session (1.41 ± 0.25 *vs* 1.25 ± 0.31 , $p = 0.003$). The mean reduction in dry weight was 0.95 ± 1.13 kg. There was no significant correlation between change in dry weight and change in refill ratio. There were no differences between baseline and repeat studies with respect to ultrafiltration volume. MAP at the end of dialysis was significantly lower in both paired sessions (110 ± 17 at start of dialysis *vs* 88 ± 18 end dialysis for session with the lower dry weight, $p < 0.0001$; 108 ± 14 *vs* 87 ± 20 for the session with higher dry weight, $p < 0.0001$: available for 20 patients). The differences between baseline and repeat pre- and post-dialysis MAP readings failed to reach statistical significance.

Table 6.4.2: RR profile of 21 patients who achieved weight reduction prior to repeat monitoring.

Where RR2_1 = final Refill Ratio during session 1, RR2_2 = final Refill Ratio during repeat session, Weight1 = achieved target weight at session 1, Weight 2 = achieved target weight during repeat session, Change in weight = Weight1 – Weight2.

Patient	RR2_1	Weight_1	RR2_2	Weight_2	Change in weight
1	1.2	75.7	1.1	75.4	0.3
2	1.3	91.4	1.8	90.4	1.0
3	1.3	63.8	1.0	63.5	0.3
4	1.3	60.7	1.1	60.5	0.2
5	1.4	72.0	1.2	71.5	0.5
6	1.0	64.2	0.8	64.1	0.1
7	1.2	69.0	0.9	68.6	0.4
8	1.3	63.2	1.1	62.9	0.3
9	1.6	92.5	1.1	92.0	0.5
10	1.2	68.3	1.1	64.5	3.8
11	1.4	64.7	1.3	64.3	0.4
12	1.6	109.6	1.5	107.8	1.8
13	1.8	72.7	1.7	72.2	0.5
14	1.8	73.8	2.0	73.1	0.7
15	1.8	48.7	1.4	48.1	0.6
17	1.8	58.0	1.4	57.5	0.5
19	1.2	78.0	1.2	77.8	0.2
20	1.3	57.3	1.2	56.7	0.6
21	1.1	67.8	0.8	64.8	3.0
22	1.6	51.5	1.3	51.0	0.5
26	1.4	80.7	1.3	77.0	3.7

6.4.5 Discussion

The study adds weight to the findings of the previous pilot data in suggesting a potential benefit for dual compartment monitoring in volume management in prevalent haemodialysis patients. In addition to confirming the finding of differences in Refill Ratio in between different phases of the same dialysis session, differences which seem to relate to the degree of volume overload, the current study also suggests that if the final Refill Ratio of the session is significantly greater than unity, it is suggestive that further reduction of dry weight is possible and may be beneficial.

This study also confirms that volume overload is common in prevalent haemodialysis patients and that modest weight reductions can be achieved without causing significant symptoms. It is not possible to make any firm statements about the clinical benefits of this degree of weight reduction on the basis of this study. Weight reductions achieved were not associated with statistically significant changes in pre- and post-dialysis blood pressure. Pre-dialytic blood pressures are difficult to interpret in this context [203] and it may be that ambulatory blood pressure measurements or at least home readings, would be more reliable index of the significance of any weight change [205]. It may be too that we allowed insufficient time to elapse to observe the full effect of on blood pressure of the achieved weight change given the well-known lag effect [598].

Dual compartment monitoring, combining CSBA and RBV, appears capable of supplying a reasonable indication of the state of vascular refilling which is a major determinant of haemodynamic stability, and hence may have a role in the providing real time monitoring during dialysis. It could be used to guide the rate of ultrafiltration, and hence may help in reducing intradialytic symptoms. To make this possible it would be helpful to refine the Refill Ratio parameter along the lines suggested in the previous chapter, and automate it's use as part of biofeedback system. As demonstrated in this study, dual compartment monitoring also has a potential role as an aid to clinical judgement in the setting of dry weight.

The absence of a correlation between change in dry weight and change in Refill Ratio across the whole group suggests that in the interpretation of this parameter, individual patients need to serve as their own control either within and single dialysis session or across dialysis sessions. The margin by which Refill Ratio differs from unity cannot be used in inter-patient comparisons to infer relative proximity to dry weight.

Chapter 6.5

Dialysate temperature and vascular refill during haemodialysis:

6.5.1 Introduction

Haemodynamic instability during dialysis is a major cause of dialysis related morbidity[599-602]. In spite of advances in dialysis technology, hypotensive episodes during dialysis complicate around 20% of all sessions. Techniques such as Relative blood volume monitoring (RBV), and sodium profiling may have some potential to ameliorate the problem.[603]

Stability on dialysis depends on preservation of blood volume which in turn depends on rapidity of vascular refill from the extracellular fluid compartment in relation to the ultrafiltration rate.

Compensatory mechanisms which ensure preservation of central blood volume include peripheral vasoconstriction, which result` in decreased cutaneous blood flow. This results in decreased heat loss from the body surface resulting in built up of thermal energy and consequent rise in core body temperature. This rise in core temperature will eventually overcome the constrictor responses, resulting in heat-induced vasodilatation. This may contribute to haemodynamic instability towards the end of a dialysis session. Intuitively removal of this built up thermal energy through the extracorporeal circuit should offset the rebound vasodilatation and promote vascular stability. This is the volume theory of dialysis induced rise in core temperature first proposed by Gotch et al.[604]

Advances in dialysis technology have enabled the temperature of the dialysate to be maintained throughout the dialysis session, but also permit it's variation during the session to provide sufficient heat loss to ensure that the patient's core temperature remains constant throughout the dialysis session (isothermic dialysis). Rosales et al³ have shown that the amount of heat needed to be removed through the extracorporeal circuit to maintain constant patient core temperature varied directly in proportion with ultrafiltration volumes. Schneditz et al[605] and others[606][607][608] observed that heat accumulation increased with blood volume decrease and the dialysate temperature had to fall to ensure isothermic dialysis. However little is known about thermal energy flow when dialysate temperatures are set a degree or half a degree lower than pre-dialysis patient core temperatures.

The aim of the study is to ascertain whether differences exist in the nature of refill during isothermic and constant dialysate temperature dialysis. Monitoring each patient over haemodialysis sessions with different dialysate temperatures (including a session in which dialysis is isothermic) will give an insight into whether an ideal temperature could be set for each patient which will optimise vascular refill thus minimising the risks of intradialytic hypotension. If vascular refill can be maximised by manipulation of dialysate temperature, achieving of dry weight becomes easier with less hemodynamic instability.

6.5.2 Methods

6.5.2.1 Patients

Twenty prevalent haemodialysis patients were studied. Their mean age was 59 ± 13 years. Their mean dialysis vintage was 25.6 ± 20.3 months. Mean duration of dialysis (T_d) was 192 ± 33 minutes. Mean blood flow (Q_b) was 316 ± 60 ml/min. All were receiving thrice weekly high-flux haemodialysis, the other characteristics of which have been described in chapters 5 and 6.1. All had definitive vascular access. In addition, all patients had a blood haemoglobin concentration of > 10 g/dl and a serum albumin level of > 30 g/l. All patients had a defined dry weight. All had been haemodynamically stable during more than 90% of haemodialysis sessions during the previous 3 months. None of the patients had refractory hypertension. None were taking more than 2 anti-hypertensive agents. None had overt left ventricular dysfunction cardiac disease – all having an ejection fraction of ejection fraction $> 50\%$ on echocardiography during the past year.

6.5.2.2 Techniques

All patients dialysed using the Fresenius 4008 dialysis machine. The following techniques were used as described in as described in previous chapters:

1. The in-built BP module of the Fresenius Dialysis Delivery System was used to record MAP.
2. The Hydra ECF/ICF Model 4200 (Xitron-Tech, San Diego, USA) was used for multifrequency BIA was used to measure ECF resistance (R_{ECF}) CSBA was obtained from a 10 cm segment of the lower leg

also as describe in the previous chapter. Data was collected continuously by connecting the Hydra 4200 to a Personal Computer laptop through a serial port.

3. The built-in Fresenius BVM module was used to continuously record RBV data.

4. The built-in Fresenius Blood Temperature Module (BTM) was used to maintain constant dialysate temperature (36°C) for the first session and in T control mode during the second session.

5. Data collection was carried out using a dedicated data concentrator which extracts the BVM, BTM information from the dialysis machine and converts it into a format which can be manipulated in a Windows based PC. Bio impedance data was collected continuously through dedicated software.

6.5.2.3 Dialysis prescription

High flux dialysis was carried out as described in Chapters 2 and 6.

6.5.2.4 Ultrafiltration prescription

The ultrafiltration prescription incorporated the technique of ultrafiltration pulsing. Stressing the system near dryness by use of pulsed ultrafiltration helps to magnify the haemodynamic responses and facilitates the study of the compensatory mechanisms involved in the preservation of central blood volume.

Ultrafiltration profile was identical to that described in chapter 6.4, reiterated here to aid interpretation of the results. The dialysis session was divided into seven unequal time segments. (Fig 6.5.1) Briefly, this comprised sequentially of:

- 5 minutes of isovolemic dialysis (HD_{iso}) at the start of the session
- 15 minutes of rapid UF (I Pulse, 15% of the IDWG)
- 10 minutes of HD_{iso} (I Rebound, R1),
- Phase of constant UF (70% of IDWG) – for [td - 65]mins
- 10 minutes of HD_{iso} ,

- 15 minutes of rapid UF (II Pulse, 15% of IDWG) - commencing 25 minutes before the planned end of the session
- 10 minutes of HD_{iso} (II Rebound, R2) - for the final 10 minutes of the session

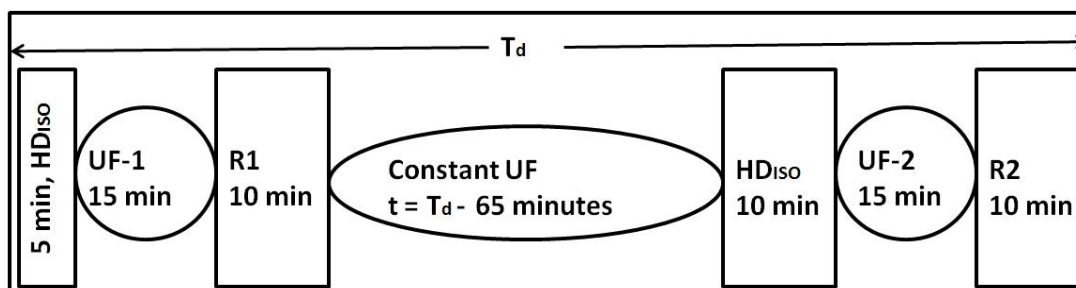

Figure 6.5.1 Ultrafiltration prescription. T_d = dialysis duration (in minutes), UF-1 = pulse ultrafiltration during which 15% of intradialytic weight gain (IDWG) was removed – duration 15 minutes; R1 = rebound 1 – a 10 minute period of isovolaemic haemodialysis to allow calculation of Refill Ratio (RR1); Constant UF = period of constant UF duration $T_d - 65$ minutes, during which 70% of the (IDWG) was removed; HDISO= a 10 minute period of isovolemic ultrafiltration; UF2 = 15 minute period of pulsed ultrafiltration during which 15% of IDWG was removed; R2 = 10 minute period of isovolaemic haemodialysis to allow rebound and calculation of Refill Ratio (RR2).

6.5.2.5 Study Protocol:

1. Each of the 20 patients underwent two study dialysis sessions. The dialysis prescription for each of these sessions, including Duration of dialysis, target Kt/V , Q_b and Q_d , was identical apart from the dialysate temperature control. The BTM was used to maintain constant dialysate temperature (36°C) for the first session (Phase N), and in T control mode during the second session during which a period of isothermic dialysis was carried out to maintain a constant core temperature (Phase T).
2. The ultrafiltration profile described above was applied in each dialysis session.
3. MAP monitoring, RBV monitoring and continuous ECF volume monitoring by segmental bioimpedance was carried out throughout both these phases.
4. Data on thermal energy changes during Phases N and T were captured from the using the BTM.

6.5.2.6 Data analysis

Haemodynamic parameters obtained during pulse ultrafiltration and subsequent rebound were compared in both temperature conditions using Students paired t test. In particular the Refill Ratio was calculated from data obtained during the R1 and R2 rebound phases (RR1 and RR2). The methodology for this was described in Chapters 6.3 and 6.4. Figure 6.5.1 shows the regions of interest in relation to typical RBV and ECF Resistance traces. Thermal energy changes during both phases of the study were also compared using Students paired t test.

6.5.3 Results

Figure 6.5.1 shows composite curves illustrating the trend of core temperature in each of the two phases of the study. The core temperature rose slightly but significantly in Phase N (36.4 ± 0.3 to $36.6 \text{ }^\circ\text{C} \pm 0.3$; $p = 0.02$). The core temperature in Phase T did not change significantly (36.5 ± 0.3 v $36.6 \text{ }^\circ\text{C} \pm 0.3$; $p = \text{NS}$)

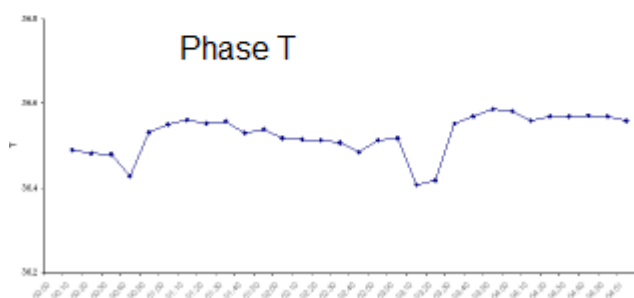
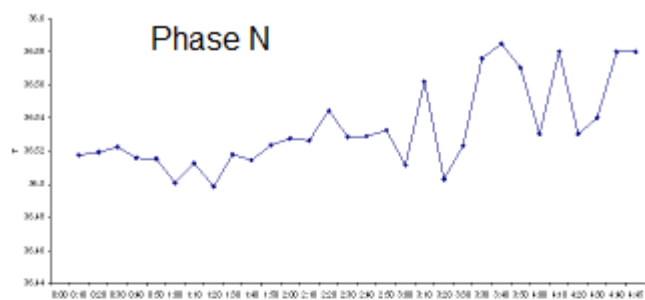

Figure 6.5.2 Composite curves showing core temperature trends during the two phases of the study. Phase N = constant dialysate temperature of 36°C, Phase T = T control mode for isothermic dialysis, MAP – mean arterial pressure.

The basic haemodynamic details during phases N and T are summarised in Table 6.5.1. There were no significant differences in any of these parameters (Table 6.5.1) between phases N and T, though both pre—and post MAP tended to be slightly higher in the isothermic phase.

	Phase N	Phase T
Weight (kg)	76.7 ± 15.4	76.7 ± 15.6
Ultrafiltration (ml)	1940 ± 795	1905 ± 800
Pre-dialysis MAP (mm Hg)	98 ± 14	103 ± 11
Post-dialysis MAP (mm Hg)	83 ± 20	88 ± 16

Table 6.5.1. Basic haemodynamic details of the two phases. Phase N = constant dialysate temperature of 36°C, Phase T = T control mode for isothermic dialysis, MAP – mean arterial pressure.

Table 6.5.2 shows the changes in RBV and energy losses during the two phases of the study. There were no significant differences.

	Phase N	Phase T
Change in RBV (%)	9.6 ± 4.6	10.6 ± 4.8
Energy loss (kJ)	172 ± 128	133 ± 109

Table 6.5.2: Change in Relative blood volume (RBV) and energy loss during during the two phases. Phase N = constant dialysate temperature of 36°C, Phase T = T control mode for isothermic dialysis

Figure 6.5.2 shows the regions of interest for the calculation of Refill Ratios (RR1 and RR2) in the setting of a typical trace pattern for RBV and ECF Resistance.

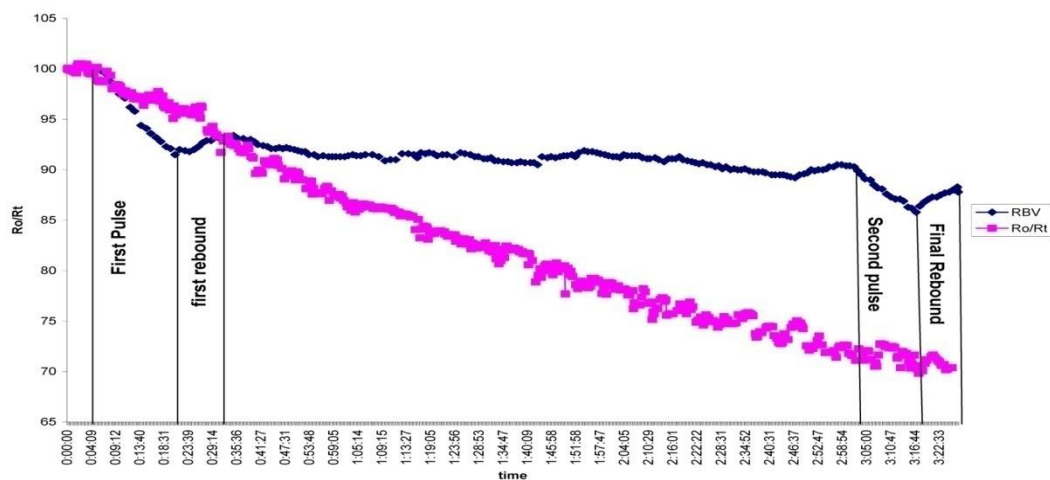

Figure 6.5.3 Regions of interest for the calculation of refill ratios RR1 (first rebound period) and RR2 (final rebound period)

Tables 6.5.3a and 6.5.3b shows the UF-1 and UF2 volumes and Refill Ratios (RR1 and RR2) for Phase N and Phase T respectively. UF-1 and UF-2 volumes during Phase N of the study were identical in 16/20 subjects studied. In four others (Case 5, 14, 15,19) there were discrepancies between UF-1 and UF-2 volumes. This occurred as a result of an error in mid-segment UF volume calculations in the study involving Subjects 5 and 14 and an asymptomatic drop in BP in subjects 15 and 19 (> 20 mm Hg systolic drop compared to the start of the UF-2 pulse) resulting in a slightly lowered UF-2 volume.

CASE	UF-1 Volume	Refill Ratio_1	UF-2 Volume	Refill Ratio_2
1	440	1.8	400	1.1
2	380	11.6	380	1.3
3	210	5.0	210	0.6
4	250	2.9	230	1.6
5	200	2.0	300	1.0
6	230	4.1	230	2.1
7	500	1.9	500	1.4
8	400	2.2	400	1.4
9	330	1.8	330	1.3
10	480	2.4	480	1.1
11	490	1.8	480	1.2
12	180	1.9	180	1.1
13	280	1.7	280	1.0
14	100	1.0	300	2.2
15	450	3.9	300	1.2
16	250	2.6	250	1.2
17	450	16.3	400	1.4
18	180	2.0	180	1.3
19	320	1.7	250	1.3
20	600	2.0	600	1.1

Tables 6.5.3a. UF-1 and UF2 volumes and Refill Ratios (RR1 and RR2) for Phase N of the study

For both Phase N and Phase T of the study, RR2 was significantly less than RR1 [3.5 ± 3.8 vs 1.3 ± 0.4 : $p = 0.016$, for Phase N, and 4.0 ± 4.6 vs 1.4 ± 0.5 : $p = 0.018$ for phase T]. In contrast, there was no difference between RR2 in Phases N and T [1.3 ± 0.4 vs 1.4 ± 0.5 : p NS]

CASE	UF-1 Volume (ml)	Refill Ratio_1	UF-2 Volume (ml)	Refill Ratio_2
1	500	2.1	500	1.3
2	380	11.5	380	1.8
3	210	3.3	210	1.0
4	250	3.3	250	1.8
5	350	2.7	350	1.3
6	280	1.2	280	1.1
7	390	5.1	390	3.3
8	380	1.2	380	1.2
9	140	2.5	140	1.2
10	330	2.6	330	1.3
11	330	2.1	330	0.9
12	230	1.7	230	1.3
13	380	1.0	380	0.8
14	100	1.7	100	1.9
15	450	2.9	420	1.2
16	200	1.2	200	1.1
17	390	18.0	100	1.3
18	180	1.4	200	1.2
19	350	13.0	350	1.4
20	550	1.5	500	1.3

Tables 6.5.3b shows the UF-1 and UF2 volumes and Refill Ratios (RR1 and RR2) for Phase T of the study

6.5.4 Discussion and conclusions

There were significant reductions in Refill Ratios between the first (R1) and final (R2) rebound phases, using both the constant 36°C dialysate and during isothermic haemodialysis. This confirms the finding of previous studies that the Refill Ratio may be a useful indicator of changing volume status during the course of a haemodialysis session.

However we failed to find a significant difference between the final Refill Ratio (RR2) in the differing temperature conditions. This is in keeping the lack of significant difference in any of the other haemodynamic parameter studied including pre- and post-dialysis blood pressures (though blood pressures were slightly higher in the constant temperature phase), and change in RBV. This indicates that there was no difference in the haemodynamic response to fluid removal between the dialysis sessions

in which the dialysate temperature was a constant 36°C and those in which the subject to isothermic control. Dialysis under both conditions was equally well tolerated.

There is good evidence, cited above, that cooling the dialysate can improve haemodynamic stability though we have found no evidence of this in this study. There may be a number of reasons for this. Firstly, stable patients were chosen for this study, whilst many of the studies which have demonstrated benefit of dialysate temperature control have done so in patients with a history of haemodynamic instability. We chose stable patients since our primary aim was to establish the utility of parameters generated from the use of the novel technique of dual compartment monitoring. Had we chosen patients with more difficult hypertension, or with clinical signs of fluid overload, benefits may have been apparent. Secondly the difference in temperature trajectory during the two phases, though significantly less in the isothermic phase, was minimal (Figure 6.5.1), and the differences between the two phases with respect to energy loss was insignificant. It is likely that many patients may have been cooled during the constant temperature phase of the study. In order to demonstrate a benefit a greater separation in energy loss between the phases would be required. This would require taking into account the patient's habitual pre-dialysis temperature in choosing the appropriate dialysate temperature control mode.

The conclusions from the study are that in stable patients, isothermic dialysis confers no haemodynamic benefit over a constant dialysis temperature of 36°C, neither with respect to differences in standard monitoring parameters such as BP and RBV, nor with respect to parameters such as Refill Ratio, generated using the novel technique of dual compartment monitoring. The study did confirm the finding of previous studies reported in this thesis, that the Refill Ratio may be a useful indicator of changing volume status during the course of a haemodialysis session.

Chapter 6.6

Effect of High Flux dialysis on plasma B-Type natriuretic peptide

levels:

6.6.1 Introduction

BNP appears less sensitive to fluid volume changes than ANP and has been thought to have but a limited role in the assessment of hydration status in dialysis patients[532,533,534]. BNP levels correlates better with the degree of cardiac dysfunction than ANP levels and is more sensitive than ANP in diagnosing left ventricular hypertrophy [536]. Similarly BNP levels have better prognostic value in the dialysis population, more cardiac events occurring in patients with the highest BNP levels during follow-up [537,538]. These and other issues relating to BNP in the dialysis population have been extensively reviewed in Chapter 4.

What has received little if any attention is the effects of high-flux therapies on BNP levels. BNP is a protein of 108 amino acids with a molecular weight of 13.3 kDa, similar to that of beta-2-microglobulin. Hence low-flux therapies will not clear the molecule. Use of high-flux membranes, in high-flux dialysis would be expected to remove BNP, and the rate of removal may be enhanced by the additional convection provided by haemodiafiltration.

This study was designed to investigate the effects of high-flux dialysis therapies on BNP levels. Study of BNP levels during these therapies would provide valuable information in its own right but would also provide the opportunity to study the response to this perturbation and gain some insight into the kinetics of BNP setting, which might include its synthetic rate. This might be a useful index of cardiac dysfunction and possibly of the response of the heart to the dialysis process.

6.6.2 Methods

6.6.2.1 Patients

Twelve patients were studied. None had clinical evidence of heart disease. Echocardiography demonstrated left ventricular hypertrophy in 7/12 patients. These patients also had diastolic dysfunction.

Data relating to the severity of diastolic dysfunction was not available. Coronary angiograms had been previously performed in 2 patients, this excluded significant occlusive coronary disease. All patients had normal ejection fractions and preserved LV function. There were no significant valvular lesions. One patient was diabetic. Causes for dialysis dependant renal failure were : reflux disease (2), polycystic kidneys (1), uncontrolled hypertension (2), familial GN (1), FSGS (1), Type I diabetes (1), and Chronic GN (4). 10/12 patients were on antihypertensive medications, 5 patients were on single agents, 3 patients on two agents and 2 patients were on 3 agents. Patient baseline characteristics are given in table 6.6.1

Parameter	All (n=12)	Male (n=8)	Female (n=4)
Age	40.3±10.8	42.2±12.5	36.5±6
Time on dialysis (months)	34.2±16.3	32.1±18.6	38.4±11.1
Length of dialysis session (minutes)	180±25	186 ± 24	168 ± 24
UF Volume (ml)	2083±1057	2375±1148	1500±583
Weight (kg)	61±13.3	67.8±10.5	48±6.4
Haemoglobin (g/dL)	12.8±1.45	12.9±1.4	12.5±1.6
Number of antihypertensive agents	1.42±0.99	1.38±1.1	1.5±0.5
Kt/V	1.37±0.2	1.3±0.2	1.44±0.14
Urine volume (ml)	683±1057	662±1071	725±1189

Mean ± SD

Table 6.6.1 Patient characteristics (Data not normally distributed)

6.6.2.2 Dialysis Prescription

All twelve patients were receiving treatment by on high-flux therapies. All used polysulfone dialysers. All had a clinically defined dry weight. The mean duration of dialysis was 180±25 minutes. Other dialysis characteristics are given in table 6.6.1. All had a clinically defined dry weight.

6.6.2.3 Dialysis and Ultrafiltration profile

The dialysis session was structured in a way designed to allow discrimination of the effects of dialysis and ultrafiltration on BNP levels, both during the application of these perturbations, and during ensuing rebound periods when sham dialysis (bypass) was in operation. The dialysis and ultrafiltration profile is shown in Figure 6.6.1

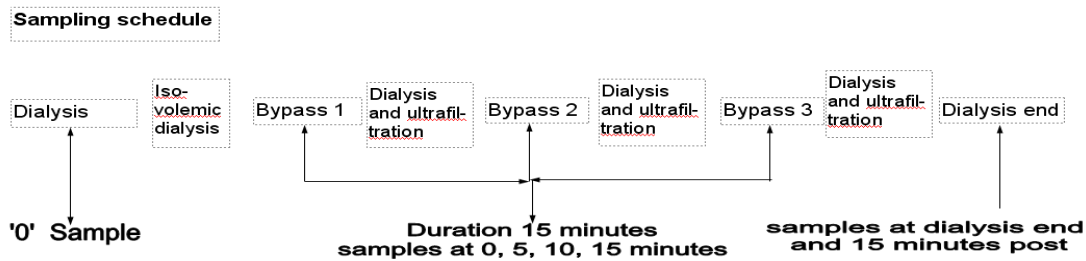

Figure 6.6.1. Schema depicting the structure of the dialysis and ultrafiltration perturbations throughout the session. The schema also depicts the BNP sampling strategy.

6.6.2.4. BNP sampling strategy

The monitored dialysis session was at the start of the week (Monday in 7 subjects and Tuesday in the rest). BNP was measured at the start, end and 15 minutes after the end of dialysis. In addition levels were measured at intervals during dialysis after a first phase of dialysis with no ultrafiltration and successively after 2 subsequent phases of ultrafiltration and dialysis (Figure 6.6.1).

6.6.2.5 Measurement of BNP

The carboxy-terminal BNP was measured by an immunoassay using a portable kit.(detection range 5-5000 pg/ml; levels in normal population <100pg/ml). The details of the assay described in Chapter 5.

6.6.2.6 Analysis

BNP values were not normally distributed and were log transformed before statistical analysis.

6.6.3 Results

All patients remained haemodynamically stable throughout. BNP levels during the study are detailed in Table 6.6.2 Eleven out of twelve patients had elevated BNP levels at the start of dialysis. Initial BNP levels ranged between 61 and 2520 pg/ml.

Subject	Start	ByPass 1				Bypass 2				Bypass 3				End	End +15
		0	5	10	15	0	5	10	15	0	5	10	15		
1	263	158	172	191	143	167	212	167	228	92	135	127	103	114	146
2	252	187	135	143	138	121	98	128	102	115	88	105	10	114	145
3	331	109	361	282	333	167	130	109	82	102	133	91	127	103	102
4	168	145	164	120	143	132	113	104	91	123	105	104	113	140	126
5	1040	454	385	428	348	429	478	424	409	320	435	336	460	441	542
6	197	133	121	174	150	182	110	102	137	147	144	139	169	186	121
7	641	273	331	268	314	493	398	406	364	481	502	482	359	376	486
8	272	92	153	141	330	175	158	204	183	261	253	198	126	195	190
9	121	43	71	48	57	62	48	61	81	67	64	56	49	60	74
10	2520	1390	1050	1680	1130	1510	903	1480	976	1300	1010	1220	977	1450	1130
11	145	33	32	48	43	57	64	69	47	89	70	72	51	73	63
12	61	26	40	36	32	41	37	28	45	47	48	29	43	48	45

Table 6.6.2 BNP levels during the study

Three patients had initial concentrations exceeding 600 pg/ml with initial concentrations over 1000 pg/ml in two patients; four patients had initial BNP concentrations between 200-350 pg/ml and five patients had concentrations between 100-200 pg/ml. The three patients with the highest concentrations had significant left ventricular hypertrophy but preserved left ventricular function. There was no correlation between fluid removal and fall in BNP during dialysis.

The changes in BNP levels during each of the phases of the study are plotted in Figure 6.6.1. Since BNP levels were not normally distributed, they were log-transformed to plot and for the statistical analysis.

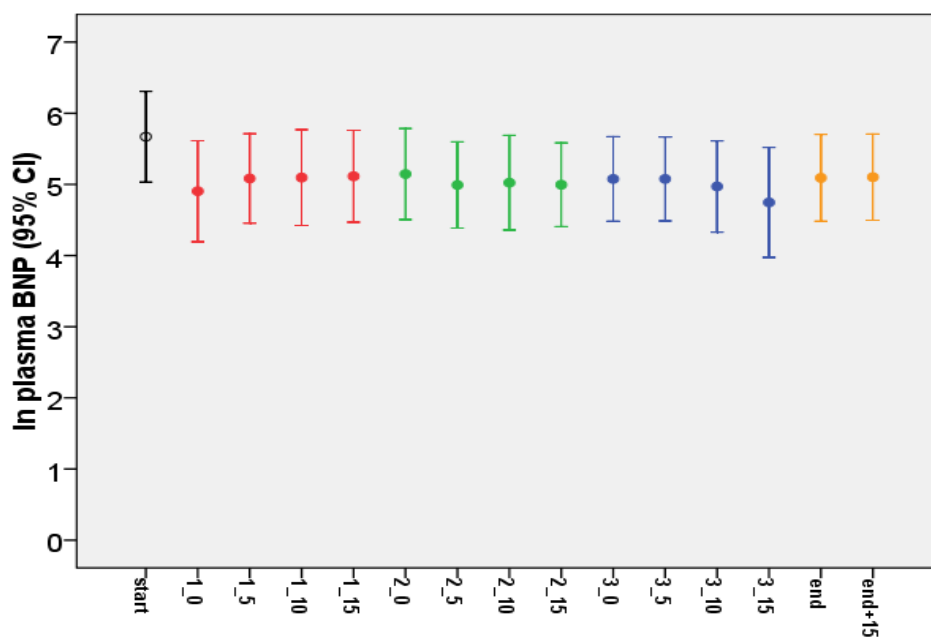

Figure 6.6.1. Plot of log-transformed BNP levels throughout the phase of the study. Initial reading is shown in black, readings during bypass 1 are shown in red, during bypass 2 in green, during bypass 3 in blue, and those at the end and 15 minutes post-end are shown in orange. The values on the X axis relate to the timings during these phases.

The BNP levels fell significantly over the course of the dialysis – the values at the end being significantly lower than starting values ($p < 0.001$). There was no significant change in levels between the end of dialysis and 15 post-dialysis. The mean reduction in BNP during the isovolemic phase was 49.3%. The major part of this fall occurred during the first period of isovolaemic dialysis ($p < 0.001$). There were no further significant falls during periods of dialysis with ultrafiltration (there being no significant difference between the 15 minute sample in bypass phase 1 and the initial – time zero – sample, in phase 2, nor between the 15 minute sample in bypass phase 2 and the initial – time zero – sample, in phase 3. In addition there were no significant changes in BNP levels during any of the bypass phase. This and the lack of difference between the level at the end of the dialysis and the sample 15 minutes later, demonstrates the absence of rapid rebound.

6.6.4 Conclusions

In summary BNP levels vary dramatically in haemodialysis patients with no overt cardiac disease even when they are at their clinically defined dry weight. BNP levels fall significantly during high flux dialysis treatments. This study suggests that the fall is early and related to dialyser clearance, the effect being akin to “emptying” a single small compartment. We found no evidence to suggest a lowering effect of ultrafiltration other than in relation to convective clearance. The effect of isolated ultrafiltration on BNP concentrations was not studied, but on the basis of our findings with respect to reductions in BNP levels in dialysis alone and in combined ultrafiltration and haemodialysis, we do not think this would have contributed. It may be that the timescales chosen during this study have obscured such an effect but one of the goals of the aspiration of the study was to ascertain whether dynamic changes in BNP levels during high-flux dialysis might contribute to our understanding of haemodynamic changes or cardiac stress during dialysis or to the patient’s prevailing fluid state. On the basis of this study this goal is not achievable. BNP known to be an important marker of cardiac dysfunction (LV Dysfunction, LV fibrosis, decreased EF, increased LVMI) in both normal and renal failure populations. It appears to be a poor marker of the prevailing fluid state.

Our data relates to BNP changes over a single modified dialysis session. There is a significant fall between the pre- and post-HD BNP levels in all studied subjects. Changes in BNP over the subsequent dialysis sessions in the week were not studied. Maisels group in San Diego[609] have reported a progressive fall in pre-HD BNP concentrations over three consecutive dialysis sessions in a week. The authors did not elaborate on the type of dialysers used in their study patients and had calculated plasma volume using an equation. There was no correlation between volume removal and fall in BNP concentrations. This may be secondary to dialyser clearance causing a fall in BNP or the lack of an appropriate refill time before the post-HD sampling had been carried out or the inability of the volume sensing mechanisms within the ventricle to respond to small changes in plasma volume. The authors felt that the dialyser clearance of the peptide may not be significant. Our study clearly shows a fall in BNP during isovolemic HD as a result of dialyser clearance. We set out to evaluate ANP as a volume marker to address the specific issues relating

to dialyser clearance, UF and vascular refill. The short half-life of ANP when compared to BNP and its secretion from atria makes it a better peptide to study in relation to volume change.

Chapter 6.7

Evaluation of atrial natriuretic peptide as a marker of hydration state in haemodialysis patients

6.7.1 Introduction

ANP concentrations are elevated in dialysis patients. Levels fall following dialysis with ultrafiltration but remain high after isovolemic conventional dialysis. [509;510] Though similar results have been reported in many other studies[511;516;610-613], there appears to be no consistent relationship between weight reduction or ultrafiltration volumes and fall in serum ANP concentrations post dialysis. In most studies ANP levels do not decrease to those found in controls, perhaps because patients remain overhydrated at the end of dialysis, or because they have occult cardiac disease. [509]. These studies confirmed the relationship between fluid overload and elevated ANP levels but fall short of demonstrating that ANP is a clinically useful tool for determining euvolemia.

There are few studies in high-flux settings. ANP is a protein of 126 amino acids of molecular weight 13.7 kDa. Clearance by low flux membranes is therefore minimal. High-flux therapies would be expected to provide clearances of a similar degree to those achieved for beta-2-microglobulin (11.8 kDa). Studying the dynamic behaviour of ANP levels during high-flux therapies may provide insights into the effects of volume reduction by ultrafiltration on ANP generation.

6.7.2 Aim

The aim of the study was to assess the effect of isolated ultrafiltration, isovolemic dialysis, ultrafiltration and dialysis successively on plasma ANP concentrations. The hypothesis was that:

- α ANP is a useful marker of the volume state in haemodialysis patients
- Isolated ultrafiltration will result in a significant decrease in α ANP levels

6.7.3 Methods

6.7.3.1 Patients

Eleven patients were studied. The selection criteria were identical to those used for the BNP study described in chapter 6.6, in particular – none of the patients had clinical evidence of cardiac disease. Patient characteristics are shown in Table 6.7.1.

Parameters	n=11
Age	62±15
M:F	7:4
Duration on dialysis (days)	1010±978
T_d (minutes)	196±34
MAP (Start) (mmHg)	96±14
MAP (End) (mmHg)	75±12
Total UF Volume (ml)	2324±699
Volume of isovolemic UF	653±256
ANP-Start (pg/ml)	249±143
ANP-End	77±65
Change in RBV during isolated UF(%)	6.6±2.6
Change in RBV during entire session (%)	13.9±5.2
Interdialytic Urine volume (ml) (median)	200

All values Mean ±SD

Table 6.7.1; Clinical and dialysis characteristics of 11 study patients

6.7.3.2 Dialysis and ultrafiltration profile

Dialysis was carried out as described in Chapter 5. Study patients were monitored during one dialysis session. The dialysis session was divided into unequal time segments as follows

1. 30 minutes of isovolemic dialysis
2. 10 minutes of bypass (extracorporeal circulation with no dialysis or ultrafiltration)
3. 30 minutes of ultrafiltration removing 30% of inter dialytic weight gain (IDWG)
4. 10 minutes of bypass
5. Combined dialysis and ultrafiltration for the remainder of the session ($T_d - 80$)

6.7.3.3 Study protocol

Blood samples were taken at the start and end of the session, at the end of each sub-phase of the study session and every 2.5 minutes during the bypass phases. In all 10 samples were collected for each study. Sampling interval during the bypass phase was 2.5 minutes reflecting the short half life of ANP. The protocol was different to that used for the BNP study so as to maximize the effect of isovolemic dialysis

and isolated UF, while recognizing a very short half life of ANP. The previous study with BNP showed that the peptide was cleared by high flux dialysis. The effect of isolated UF was not studied. In the case of ANP, it was hypothesized that changes during isovolemic HD and isolated UF would help better characterize the relationship between changes in peptide concentrations and volume removal.

Blood samples were centrifuged at 5 °C for 10 minutes at 4000rpm and were immediately frozen at -70 °C before analysis in batches.

Relative blood volume monitoring was done throughout dialysis. Blood pressure was monitored every 10 minutes. Figure 6.7.1 illustrates the study protocol and the sampling times.

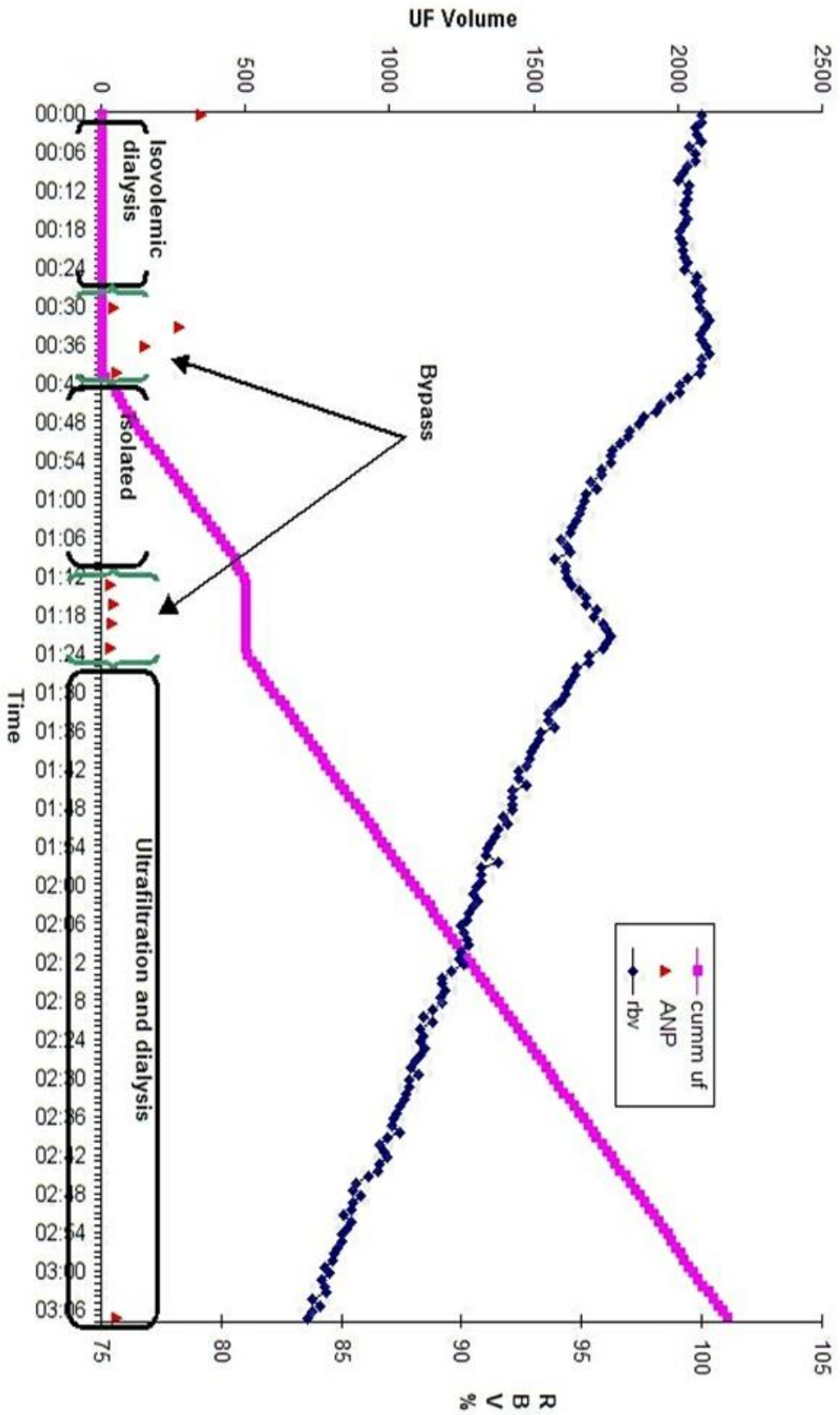

Phases during dialysis

Figure 6.7.1: Schema of sub-phases of study and sampling intervals

6.7.3.4 ANP assay:

Samples were batch analysed through a radioimmunoassay to measure the ANP concentrations. The carboxy terminal component of the intact peptide was assayed (α ANP). This fraction is the predominant circulating fraction and is responsible for most of the end organ effects of ANP. The ranges in the normal population are 15-55 pg/ml. The assay has been validated in various situations including the dialysis population and has been in use since 1992. Further details of the assay were described in chapter 5.

6.7.3.5 Statistical Analysis

ANP levels were normally distributed – parametric statistics were applied

6.7.4 Results:

Nine out of the 11 patients tolerated the modified dialysis session without problems. Two patients experienced intradialytic hypotension and ultrafiltration in phase 5 was terminated 5 and 10 minutes before the scheduled end.

ANP concentrations at the start of dialysis ranged between 70.5-578 pg/ml. ANP levels fell during dialysis (Figure 6.7.2), mean ANP concentration falling from 249 ± 143 pg/ml (mean \pm SD) at the start of dialysis to 77 ± 65 pg/ml at the end of the session ($p < 0.001$).

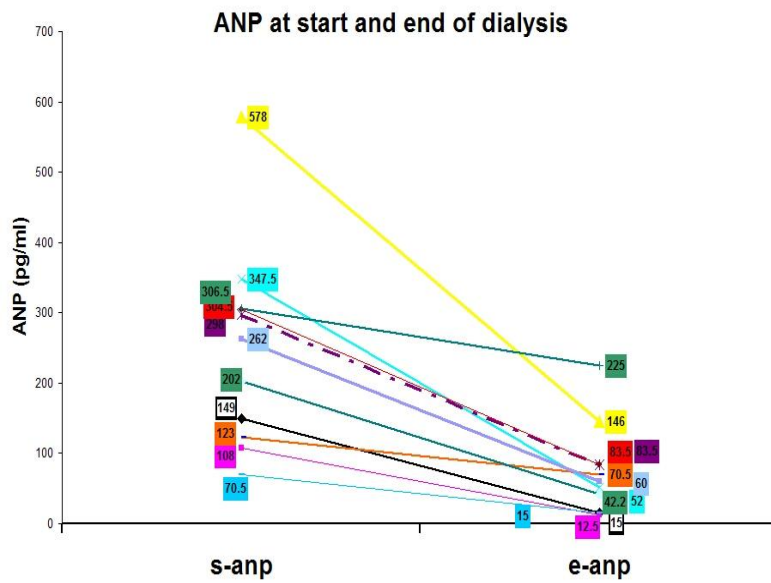

Figure 6.7.2 ANP levels at the start and end of the dialysis session.

Four out of the eleven patients had post-dialysis concentrations well below the normal range probably indicating a combination of dialytic removal and decreased generation in response to fluid removal.

Figure 6.7.3 shows the changes in ANP levels during the different phases of the study. A substantial fraction of the peptide was removed during isovolemic dialysis (249 ± 143 pg/ml to 135 ± 131 pg/ml; $p < 0.003$). There was no significant change in levels during isolated ultrafiltration. However during the rebound phase following isolated ultrafiltration there was a significant fall in ANP concentrations from 136 ± 99 pg/ml to 101 ± 77.2 pg/ml ($p < 0.02$). This is likely to be due to the suppressive effect of reduced intravascular volume, induced by ultrafiltration, on ANP generation. There appears to be a short time lag between the ultrafiltration-induced decrease in intravascular volume and the suppression of ANP generation, an effect which has been unmasked by the short period of sham dialysis following the ultrafiltration pulse. The final phase of dialysis with ultrafiltration was associated with a non-significant reduction in circulating ANP concentrations (101 ± 77 pg/ml to 77 ± 65.6 pg/ml, $p = 0.11$).

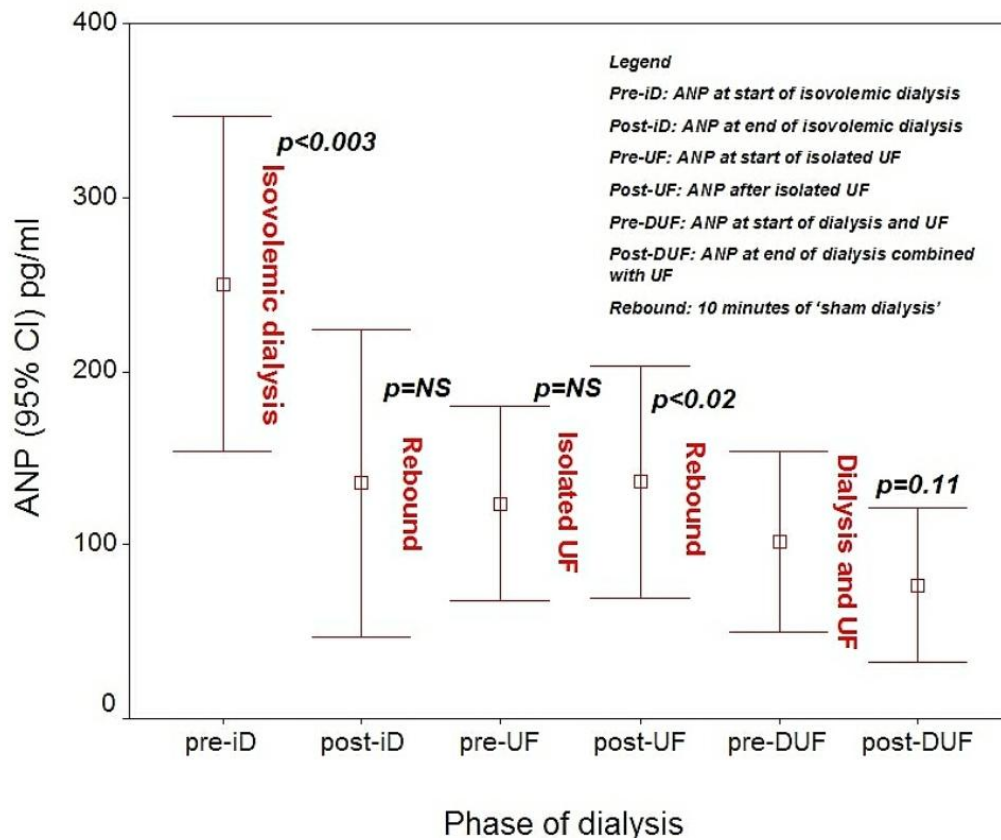

Figure 6.7.3: Error Bars representing serial ANP concentrations through different phases of dialysis

6.7.5 Discussion and conclusion

It is known that plasma concentrations of ANP are significantly elevated in the dialysis population both with and without cardiac disease. Dialysis (most studies have been in patients on low flux treatments) causes a substantial reduction in the ANP₉₉₋₁₂₆ concentrations but not to normal. There is no correlation between decrease in ANP₉₉₋₁₂₆ concentrations and achievement of euvolemia.

In this study it has been observed that isovolemic high-flux dialysis removes a substantial fraction of the

circulating peptide and in spite of prevalent volume overload, implying that the dialyser clearance of ANP removal overwhelms the ANP generation rate. This high removal on dialysis could partly explain concentrations reaching normal ranges in a few of the study patients.

The effects of isolated ultrafiltration, or isovolemic dialysis in a high-flux treatment setting have not been studied previously. Our data suggests that isolated ultrafiltration does not cause a contemporaneous reduction in ANP levels implying that volume removal does not result in an immediate switching-off of ANP release/synthesis. However, after a short lag period concentrations do fall significantly suggesting a rapid but not immediate suppressive effect. Interestingly, this observation would have been masked without a period of sham dialysis (bypass). These observations suggest that with the right sampling conditions dynamic changes in ANP during the dialysis procedure could provide clinically useful information concerning volume status in these circumstances.

At the end of dialysis vascular refill continues to restore effective intravascular volume. Monitoring this phase with serial ANP determinations will provide useful information regarding the usefulness of this peptide as a marker of the prevalent hydration state. It is as yet unknown as to what the precise time point would be when sampling needs to be done post-dialysis. The next clinical study is designed to help elucidate this.

Chapter 6.8

Evaluation of Atrial Natriuretic Peptide as marker of fluid status in haemodialysis patients

6.8.1 Introduction

Natriuretic peptides have been studied extensively in the field of cardiology since the discovery of ANP by de Bold and co-workers in 1981[614]. ANP promotes rapid diuresis and natriuresis in the setting of acute volume overload. While there is considerable evidence for the role of ANP in various cardiovascular disease states, its role as a volume marker in renal disease remains inconclusive. In one of the earliest studies Eisenhauer et al observed increased ANP immunoreactivity in 70 patients on regular haemodialysis [615]. Subsequent to this a large number of studies have reported elevated concentrations of all the natriuretic peptides (ANP, BNP, CNP, DNP and cGMP) in the dialysis population.[615-621]. It has also been observed that elevated ANP and BNP concentrations also predict prognosis in patients with cardiovascular disease. The association has also been extensively reported in the kidney disease cohort and in patients on long term haemodialysis and peritoneal dialysis.[622-626]. The half life of ANP is comparatively short in relation to BNP, which is a factor in the preference of ANP over BNP as a volume marker [627].

The process of high-flux haemodialysis clears a substantial proportion of the circulating peptide. One might also expect ultrafiltration to reduce ANP levels. Distinguishing the effects of ultrafiltration from those of dialysis clearance may well prove difficult. In addition, if there is a post-dialysis rebound in ANP concentrations in association with post-dialysis blood volume rebound, then the magnitude of ANP rise might also be a useful indicator of proximity to dry weight. This study was designed as the pilot phase in the study of ANP kinetics during high-flux dialysis. The long-term goal of this was to evaluate the potential usefulness of changing plasma concentrations in response to dialysis and ultrafiltration ANP in predicting the degree of hydration in haemodialysis patients.

6.8.2 Subjects, materials and methods

Eight stable haemodialysis patients were studied were studied.

Phase 1

In phase 1, two patients, blood samples (Li-Heparin tubes for ANP and EDTA for BNP) were obtained every 20 minutes throughout the dialysis session. Sampling was continued throughout the inter-dialytic period (6, 8, 12, 24, 48 hours post dialysis). These two patients were chosen to be at opposite ends of the fluid volume spectrum. Subject 1 was hypertensive with left ventricular hypertrophy and suffered from chronic volume excess. Subject 2 had a volume state clinically much closer to euvolemia. The purpose of this pre-pilot phase was to gain some general perception of the pattern of ANP and BNP levels during dialysis, during the immediate post-dialysis period, and through the interdialytic period. This was important in deciding on the sampling times for future pilot studies.

Phase 2

This was a small pilot study (6 patients) designed to examine the patterns of behaviour of ANP during dialysis and throughout the putative rebound period, with the ultimate aim of facilitating the design of studies to test the hypothesis that changes in ANP levels during and immediately after a session of high-flux dialysis are indicative of volume status. Sampling times were determined with reference to the results of Phase 1 and with reference to the known RBV rebound which is normally complete within 45 minutes of the end of dialysis. Post rebound the intravascular volume can be assumed to be in a steady state at least for a few hours and during this steady state ANP generation may well remain constant. With these considerations in mind the sampling schedule in this second phase was determined to be every 20 minutes throughout the dialysis session and for 2 hours post dialysis.

Samples were collected and refrigerated at -20 °C after separation of plasma by chilled centrifugation (at 4000 rpm for 5 minutes at 5 °C). Samples were transported frozen to Royal Gwent Hospital, Newport for the ANP radioimmunoassay [628]. BNP was measured in-house using a fluorescent immunoassay as described previously.

RBV monitoring was carried out throughout dialysis and for 2 hours post-dialysis in the two subjects and for one hour post-dialysis in the other six.

6.8.3 Results

The ANP and BNP results for Subject 1 are shown (Fig 6.8.1 and 6.8.2)

6.8.3.1 Subject 1

The ANP and BNP concentrations are represented as actual values. Ultrafiltration volume was 2500ml with dialysis duration of 180 minutes. The MAP decreased from 103 mm Hg at the start of dialysis to 78 mm Hg at the end of dialysis. There was a substantial fall in blood pressure just prior to the end of the session with MAP nadir of around 60-65mm Hg.

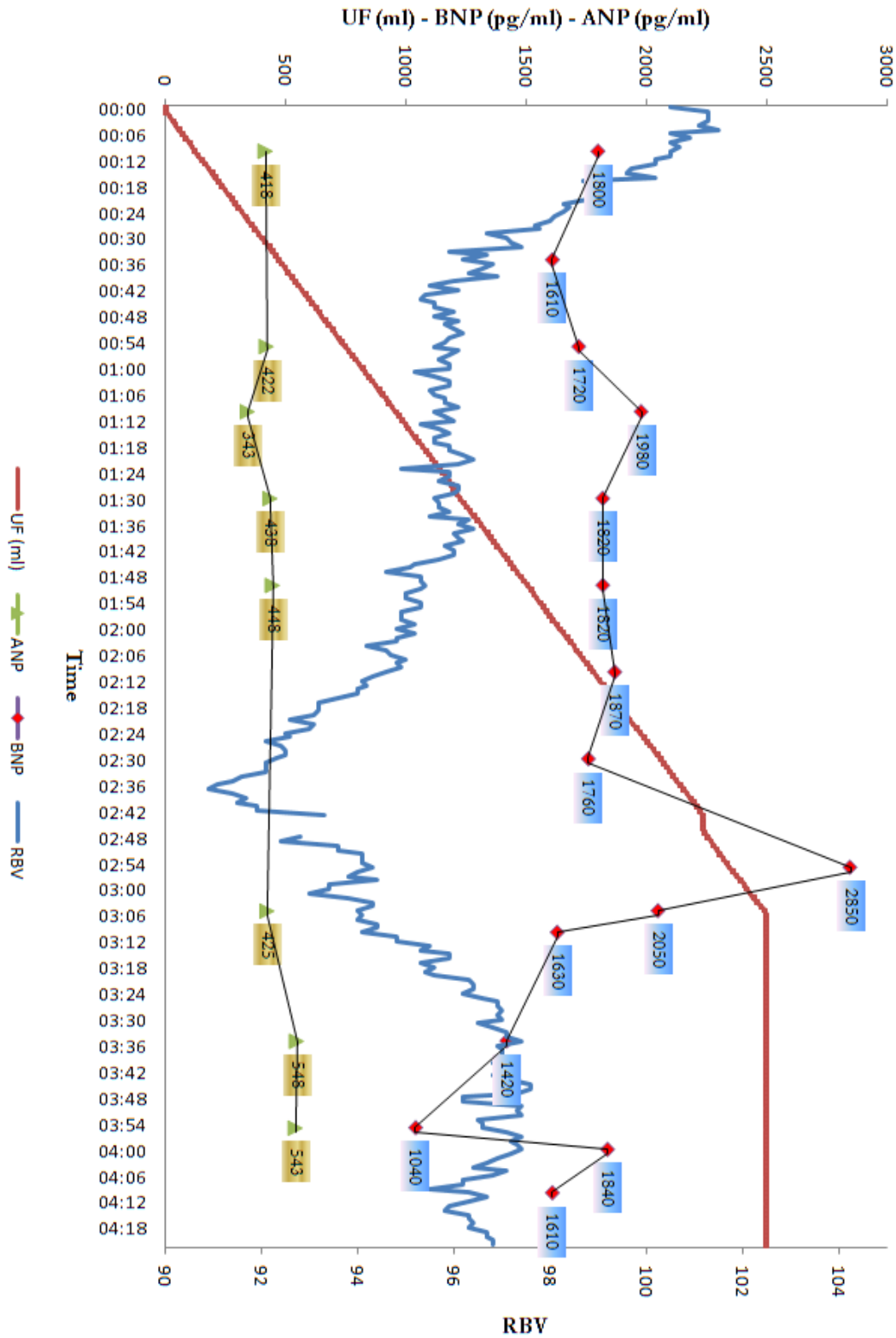

Fig 6.8.1: Subject 1. ANP and BNP concentrations during dialysis along with RBV and UF traces (see Key)

The pre-dialysis concentrations of ANP and BNP were 418 and 1800 pg/ml respectively. The ANP concentrations were not significantly affected by fluid removal, remaining grossly elevated throughout. The subject had substantially fluid overloaded. The flat response implies a high rate of ANP synthesis which counterbalanced removal during dialysis.

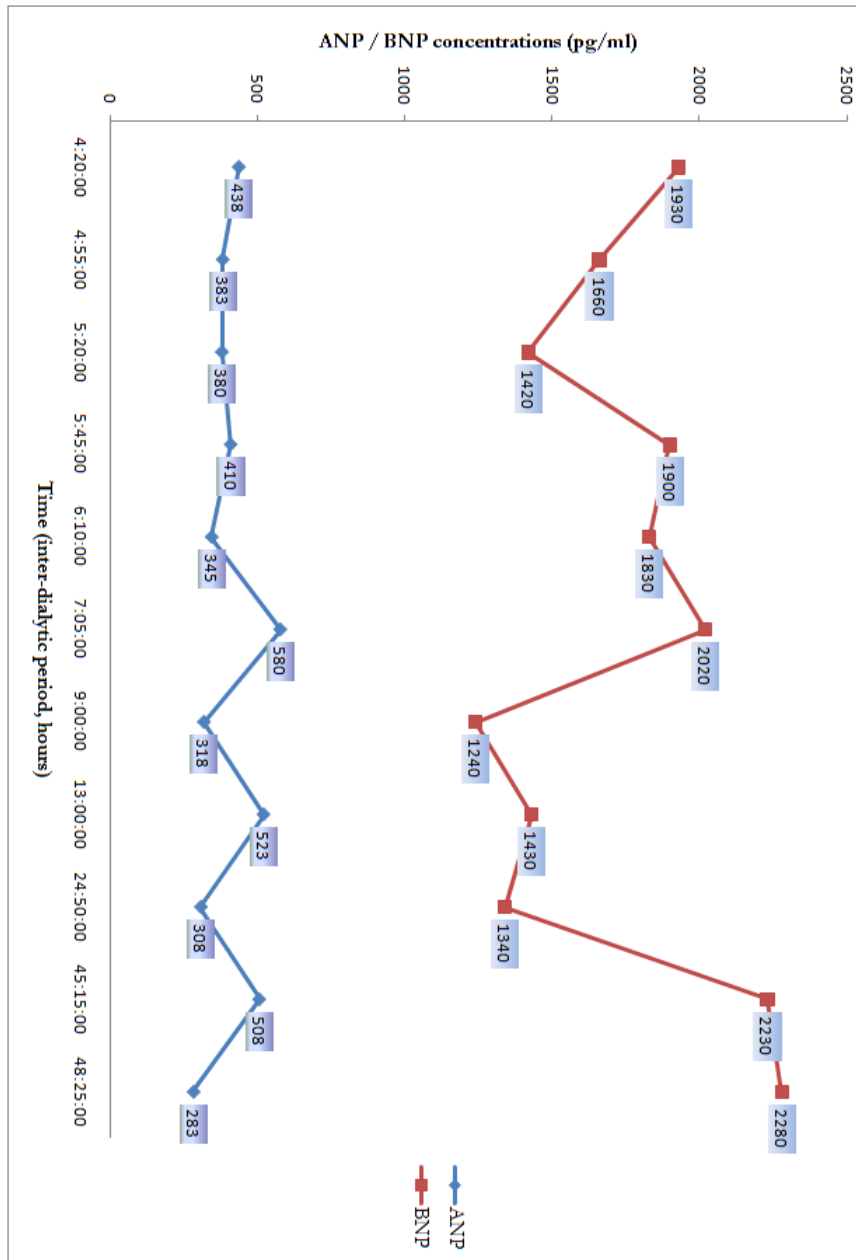

Fig 6.8.2: ANP and BNP concentrations in the interdialytic period (Subject 1)

The ANP concentrations remained elevated throughout the inter-dialytic period. There was a substantial reduction following the second dialysis session (508pg/ml to 283 pg/ml).

The BNP concentrations mirrored those of ANP but were even more substantially increased.

Interestingly, there was a spike in BNP concentrations towards the end of dialysis that was also associated with a significant drop in the mean arterial pressure. This was hypothesised to be related to myocardial ischaemia (stunning). The large number of samples taken during the dialysis session and subsequent inter-dialytic period suggests that results that are reproducible within the same patient, both for ANP and BNP.

6.8.3.2 Subject 2:

The dialysis duration was 180 minutes. The volume removed on ultrafiltration was 350 ml. The mean arterial pressure was 86 mm Hg at the start, 86 mm Hg at the end and 86 mm Hg an hour after the end of dialysis. The ANP and BNP values obtained along with the RBV profile is illustrated below.

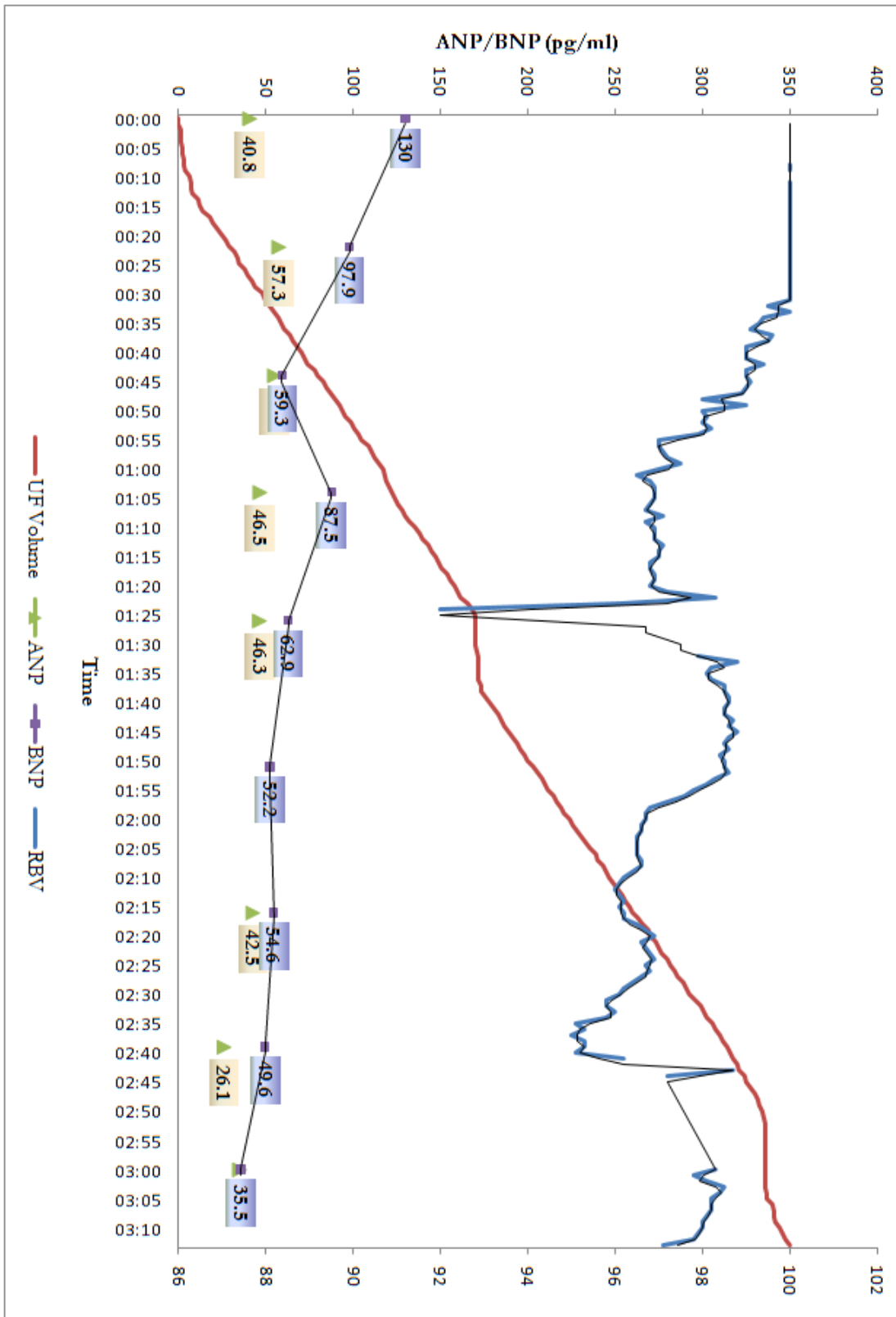

Fig 6.8.3: ANP and BNP concentrations, RBV and ultrafiltration trace during dialysis in subject 2

The ANP and BNP concentrations were marginally elevated pre-dialysis. As the dialysis progressed the levels fell partly as a response to fluid removal and partly due to the dialytic process itself. In the interdialytic period the concentrations remained almost within the normal range for both ANP and BNP and rose again before the next dialysis session.

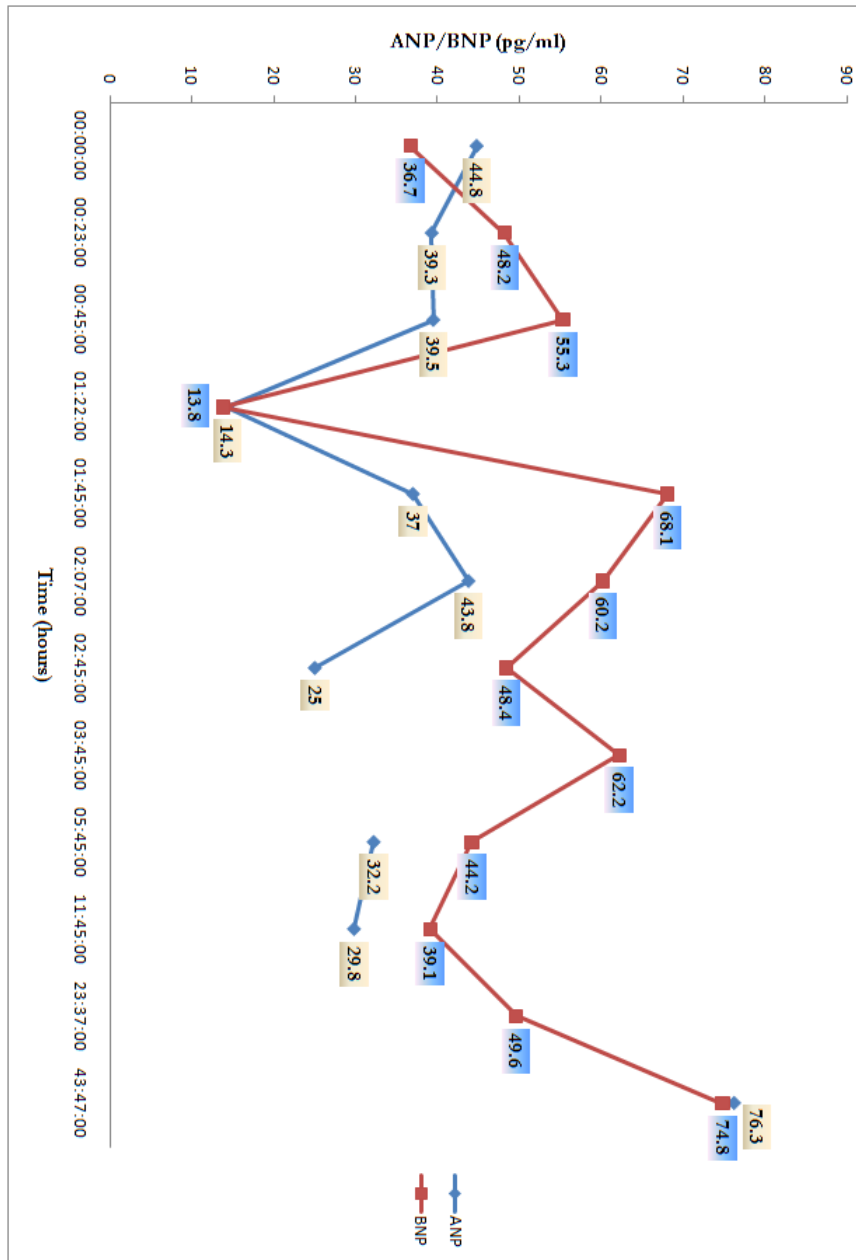

Fig 6.8.4: ANP and BNP concentrations in subject 2 during the inter-dialytic period

6.8.3.3. ANP profiles in the second cohort (n =6)

The demographic and clinical details of this group of patients are detailed in Table 6.8.1.

Table 6.8.1: Subject demographics. HD Vintage = haemodialysis vintage in months, Td = duration of dialysis session in minutes, AntiHT = number of antihypertensive drugs, Kt/V = dialysis adequacy, Hb = haemoglobin levels (g/dl), Qb = blood pump speed (ml/min), Tx List: “0” indicates that the patient was active on the cadavaeric waiting list, and “1” that the patient was not active.

Id	Age	HD vintage	Td	AntiHT	DW	Kt/V	Hb	Qb	Tx List	UF
1	50	24	180	1	101.8	1.12	12.6	450	0	1900
2	64	72	235	3	67.5	1.11	12.3	350	0	2400
3	69	24	165	0	76.5	1.29	12.4	400	0	1300
4	60	18	175	2	90	1.14	10.9	450	1	3100
5	72	23	195	1	95.8	1.27	11.8	350	1	1100
6	62	60	199	1	55	1.31	12.1	350	0	1451

The mean arterial blood pressures remained stable throughout dialysis. The RBV responses to ultrafiltration differed between patients in relation to their degree of fluid overload. The ANP levels varied widely between patients (Table 6.8.2)

Table 6.8. 2: ANP concentrations in all six patients. (De: end of dialysis session, De + 1: one hour post-dialysis, De + 2: 2 hours post dialysis)

Pt id 1	Time (min)	ANP (pg/ml)	Pt id 2	Time (min)	ANP (pg/ml)	Pt id 3	Time (min)	ANP (pg/ml)
	0	259.0		0	102.5		0	277.0
	20	152.0		20	54.4		20	258.0
	40	150.0		40	41.4		40	173.1
	60	136.0		60	49.4		60	159.5
	80	98.5		80	35.0		80	42.5
	100	107.5		100	46.9		100	125.0
	120	103.5		120	25.0		120	121.9
	140	100.5		140	26.0		140	97.2
	160	76.0		160	27.2		160	152.8
	168	83.0 De		180	35.6 De		180	129.2
	188	75.5		200	48.1		200	226.0
	208	96.0		220	35.6		220	135.0 De
	228	92.0 De+1		240	32.0 De+1		240	19.5
	248	126.5		260	22.1		260	110.7
	268	142.5		280	54.0		280	122.8 De+1
	288	146.0 De+2		300	no result De+2		300	130.7
							320	137.1
							340	21.4 De+2

Pt id 4	Time (min)	ANP (pg/ml)	Pt id 5	Time (min)	ANP (pg/ml)	Pt id 6	Time (min)	ANP (pg/ml)
	0	39.5		0	71.0		0	6.5
	20	15.0		10	65.5		20	6.0
	40	21.9		20	65.5		40	17.0
	60	23.3		40	69.0		60	4.0
	80	16.7		60	58.5		80	8.0
	100	19.2		80	18.5		100	7.5
	120	14.4		100	24.0		120	8.0
	140	27.9		120	2.0		140	8.0
	160	36.3		140	0.5		160	8.8
	180	13.3		150	0.5 De		180	0.5 De
	200	17.5 De		170	2.5		200	13.3
	220	45.8		190	5.5		220	19.0
	240	20.6		210	12.0 De+1		240	26.0 De+1
	260	30.6 De+1		230	17.0		245	51.5
	280	25.0		250	5.0		260	36.0
	300	10.0		270	11.0 De+2		280	43.5
	320	27.5 De+2					300	28.0 De+2

Composite ANP results in all 6 patients plotted against discrete composite dialysis time points indicate a significant decrease in ANP concentrations beginning early in the dialysis period and levelling off towards the end of dialysis (Fig 6.8.5). The early fall is due to removal by dialysis, the plateau phase indicates the

rate of removal is approximately equal to the rate of release. Though not illustrated, RBV rebound in all 6 patients was complete within 40 minutes of dialysis cessation. The ANP rebound appears to be complete ANP concentrations however begin to plateau around at around 80 minutes post-dialysis. It should be noted though that none of these rebound values were significantly different from the value at the end of dialysis (d10), though the value at 100 minutes approached significance ($p=0.058$). However, the sample size was very small at only 6 patients.

The time to maximum rebound following dialysis cessation would be expected to be determined by a number of factors. These include

- the results of any compartmentalisation, which in view of what is known of the molecular size and distribution of ANP, would be expected to be minimal;
- the time till completion of fluid rebound, which may be expected to increase ANP generation especially if associated with a return to an overfull blood compartment
- any lag time between the completion of fluid rebound and ANP release.

It would appear from figure 6.8.5 that both these components are complete in 80 – 100 minutes, and that a sample taken at this time would be likely to be representative of the post-rebound ANP level.

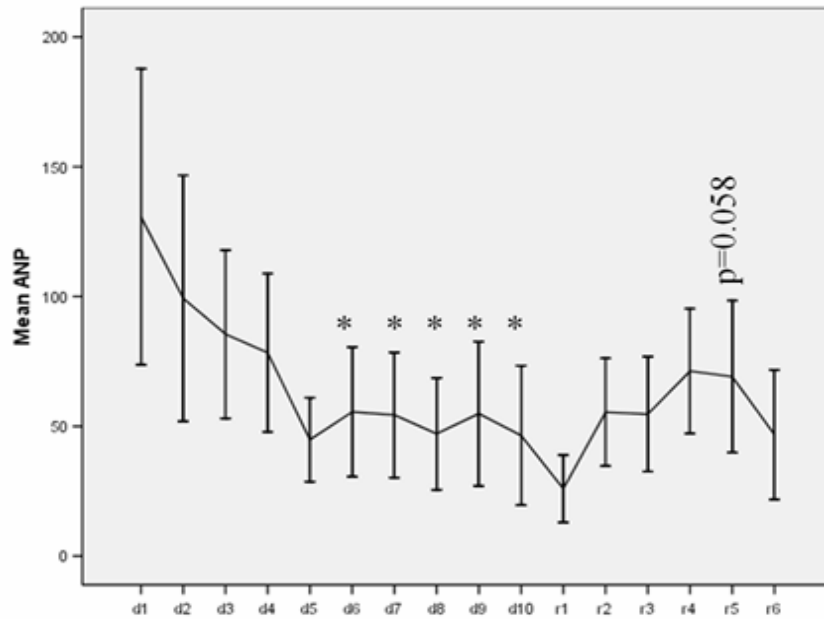

Figure 6.8.5: Delayed rebound of ANP concentrations in the post-dialytic period

The composite ANP values in the post-dialytic period are significantly lower than concentrations at the start. There is a tendency towards a significant rise after the cessation of dialysis which peaks between 1-2 hours. * indicates significant difference from pre-dialysis values (d1). $p = 0.058$ indicates the maximum level of significance (at r5) between rebound values and the value at the end of dialysis (d10).

6.8.4 Conclusion

The study highlights the difficulty in teasing out ANP responses to ultrafiltration during high-flux dialysis. Dialysis induces a constant rate of ANP removal, and ultrafiltration would be expected to reduce the rate of ANP generation at least if hypervolaemia is corrected. It is also possible that there may be some enhancement of baseline synthesis in response to rapid removal. How dialysis may affect the rate of catabolism by neutral endopeptidase is not known. Post-dialysis ANP rebound occurs and appears to be complete by 80 – 100 minutes after cessation of dialysis. ANP rebound is a complex of a number of factors including the response to fluid rebound, and the lag time between completion of fluid rebound and ANP release. It may be though that an ANP level at 80-100 minutes post-dialysis would be a useful adjunct in the assessment of volume status in haemodialysis patients. Further work would be necessary to

determine this. The pilot data presented here may also form the basis of mathematical models to better define the kinetics of ANP during high-flux haemodialysis which may help determine whether plasma ANP levels can make a contribution to fluid assessment in this setting. Further studies may allow an 'equilibrated ANP' level (post-rebound) to be generated from a immediate post-dialysis ANP value, the 'equilibrated ANP' level being likely to be the best indicator of post-dialysis volume status.

Chapter 7

Discussion

The last twenty years have posed different challenges to the clinicians managing ESRD patients on haemodialysis. During the initial evolution of in-centre haemodialysis the practice was to provide 4 hours thrice weekly sessions with modified cellulose dialysers with acetate used as the dialysate buffer. The cohort of patients entering these programmes were younger, with lesser comorbidities and much less cardiovascular disease burden. Fast forwarding 20 years or so, technology has moved forward with the introduction of synthetic membranes, sophisticated dialysis delivery systems, bicarbonate buffer, high flux dialysis, haemodiafiltration and more importantly substantially shorter dialysis sessions. The era of short duration dialysis had truly arrived. Widespread application of the UKM concept to define the adequacy of dialysis was embraced in its various forms and a shift occurred defining adequate dialysis just based on solute clearances. There was no easy definition of adequate salt and water management which has contributed to it becoming a poor relative in determining the quality of dialysis on offer. The attitudes to RRT had also changed by then, with changes in the remuneration structures, increased expansion and the resurgence of interest in home dialysis resulting in a more pragmatic approach to patient selection for RRT. Over the last 10 years the UK renal registry has reported on the increase in the median age of prevalent haemodialysis patients and the increased cardiovascular disease burden in older patients. In many ways this has compounded the problem of salt and water management.

Our retrospective dry weight study compares our patient cohort with that studied by Charra *et al* highlighting a significant age shift towards the older end of the population. These groups of patients pose a difficult problem with often poor tolerances to fluid removal resulting in considerable intra-dialytic morbidity. High UF rates over shorter sessions further increases the risk of chronic fluid overload coupled with hypotension during dialysis in many instances. A majority of patients, therefore, remain fluid overloaded and hypertensive with consequent poor long term cardiovascular outcomes. This scenario has been approached from the viewpoint of optimising fluid removal during dialysis using various technologies as described in the introductory chapters of this thesis.

Identification of this, often, covert hypervolemia has been attempted by either directly or indirectly measuring body compartment volumes using techniques such as relative blood volume monitoring and bioimpedance. Biofeedback algorithms have been available to clinicians based on RBV monitoring allowing pre-set decay patterns to be achieved during dialysis by changing UF rates, conductivity or temperature. These interventions have been shown to decrease the incidence of IDH. Application of RBV monitoring during dialysis defines relative changes in volume with poor correlations with absolute blood volume (ABV), TBW or ECF changes. Therefore assessments of dry weight based on a RBV trace can be erroneous, particularly when identical traces are not consistently seen within patients over multiple sessions. Absolute measurements of ECF or TBW volumes are impossible to implement in routine clinical practice.

To address these shortcomings the investigator proposed the use of bioimpedance and RBV monitoring continuously during dialysis to capture simultaneous changes in the ECF and intravascular compartment in real time. The work done so far has demonstrated the feasibility of this approach and its simplicity. Furthermore a biochemical marker of the hydration state has also been explored that has the potential to identify post dialysis hypervolemia even in the presence of cardiac disease.

Bioimpedance technologies have gained widespread use in the dialysis field with a wide choice of techniques and equipment available to measure individual body compartment volumes pre- and post-HD. The technique has always been plagued by having Standard Errors of Mean (SEM) of measured volumes of 1-2L in the case of ECF and a slightly larger value for TBW. ICF estimations compound this error due to algorithms in current use. No consensus exists as to what methodology is more applicable in the dialysis population. Good correlations with anthropometric data and isotope dilution methods have been described with single frequency, dual frequency, multifrequency, whole body or segmental methods in the dialysis population. This often confuses rather than clarifies. The complexity of the tiers of modelling equations needed to be solved from the point of measuring electrical impedance to the derivation of a volume is beyond the scope understanding of many busy clinicians. This has firmly remained within the remit of the biomedical engineering community who have incomplete understanding of the haemodynamic responses in a typical dialysis patient when stressed with UF. The lack of data available

from a suitably large dialysis cohort that has undergone isotope dilution methods to act as a reference population has meant that the algorithms are potentially fallible when applied to individual patients' volumes.

It is therefore logical to consider a more simple approach using the modelling data in its least complex form and then relating this to events happening to the patient during fluid removal. This approach was first described by Zhu *et al* at the Renal Research Institute in New York. The investigator underwent training and familiarisation with the technique in this institution but subsequently modified the technique for use along with RBV monitoring.

This concept of dual compartment monitoring forms one of the cornerstones of the thesis. Various aspects of this technique were explored in the preceding chapters to ascertain its usefulness in real time monitoring of fluid shifts from ECF to the intravascular compartment. A pilot study demonstrated the simplicity of application and also was able to identify the amplified fluid shifts during pulse UF. A concept of Refill Ratio was evolved to define vascular refill. This is a novel concept and has provided an elegant way of identifying the hydration status towards the end of a dialysis session without resort to actual calculations of compartment volumes. The validity of this technique was further explored in prevalent patients by employing UF pulses at the start and end of a dialysis session. The refill ratio consistently dropped during the rebound following the second pulse confirming ECF emptying. Further comparisons of these values within the same patient during subsequent dialysis sessions with a lower dry weight had shown a significant decrease implying decrease in ECF volume and a lower truer dry weight. These studies were done in prevalent patients who had an established dry weight. The hidden hypervolemia in these patients can therefore be sensitively picked up by the dual compartment monitoring technique.

The definition of refill ratio as an indicator of convergence of the RBV and R_{ECF} traces in the rebound phase can also be developed further as the area of the parallelogram enclosed by these respective traces. This approach would facilitate automation and improve accuracy. A larger area during the second

rebound would indicate closer 'proximity' to dry weight which could be iterated during subsequent dialysis sessions to help in 'fine tuning' the dry weight. Effectively the technique can also identify cessation of vascular refill and hence can be used to programme fluid removal in symptomatic patients by plotting both intravascular and ECF changes.

The effects of various factors on the R_{ECF} change during dialysis with UF was explored by varying electrolyte compositions and temperature of the dialysate fluid. The traces obtained during dual compartment monitoring were reflective of UF induced volume changes indicating a lack of significant influence of electrolyte gradients on R_{ECF} . The technique was also usable during brief changes in posture with no discernible fluid shifts occurring during different positions of the segment. These influences have not been systematically described before and given the relatively new introduction of this variant of BIS to clinical practice, the investigator had felt it important to define any limitations in its applicability to the dialysis population.

While electrolyte changes and changes in posture did not elicit any changes to the ECF volume tracked by the CSBIS, the effects of temperature and isovolemic dialysis were explored in detail separately. The effects of isothermic HD was compared with standard dialysate temperature of 36 °C to identify whether a difference existed in the refill ratios between the two sessions in individual patients. There were no differences primarily because isothermic HD in the studied group of patients was remarkably close to the core temperatures reached as a result of exposure to the 36 °C. This is in contrast to the significant differences in incidences of IDH observed by Maggiore's group during their RCT comparing an isothermic to energy neutral (core temperatures increased throughout dialysis) environment.

Isovolemic dialysis elicited a significant change in R_{ECF} that initially suggested a fallibility of the CSBIS technique, implying inability of the modelling algorithm to fit raw data when patients were monitored in situations of apparent euolemia during dialysis. Closer examination however would suggest an extreme sensitivity of the technique to an interplay of factors that occur during a dialysis session. Urea disequilibrium, changes in posture causing prolonged fluid shifts, diminished vascular reactivity, effects of vasodilatory agents and the prevailing dialysate-plasma sodium gradient all play a part in causing real fluid

shifts between the ECF and elsewhere. These changes need to be systematically explored in a larger number of patients. Such fascinating changes have not been captured before and tend to be masked when WBIA or equivalent techniques are used to calculate absolute volumes. This finding offers newer insights into vascular compartment behaviours during dialysis and may increase the clinician's awareness of the fragility of the compensatory mechanisms in some patients ie hypotension in the absence of UF 30-40 minutes into a session may not be a dialyser reaction.

There is a wide variation in the measured R_{ECF} in the same subject when repeated over multiple sessions. This observation is explained by the previously mentioned sensitivity of the technique to small changes in volume. Changes in patterns of fluid distribution between different dialysis sessions, gravitational effects, environmental variables like temperature may also contribute. These changes will be masked when a whole body bioimpedance method is used as changes in individual body segments could offset each other. This indicates that the absolute value of R_{ECF} cannot be used to judge the volume state and small changes in measured R_{ECF} between various dialysis sessions can lead to erroneous modelling as these effects can be magnified by the modeling algorithms. Monitoring trends of change using the segmental technique avoids these problems. In this respect, the CSBIS technique for monitoring changes in the ECF is very similar to RBV monitoring. In fact, studying a small body segment as in CSBIS may even confer advantages in amplifying the sensitivity of the tracking technique.

Lastly, CSBIS profiles were repeated in multiple sessions in same patients to identify trace variability and relate this to UF volumes during each session. The R_{ECF} change was modelled for the first 60 minutes and fitted into a one phase exponential decay model with a tight correlation between the rate constant and UF rate. The latter two thirds of the session was characterised by the transformation of the exponential decay to a linear pattern. The duration of the exponential and linear phases during a dialysis session is speculated to be indicative of vascular refill and a long exponential phase may indicate a 'full' ECF requiring further re-adjustments of the dry weight. These hypotheses were not explored in this thesis but remain a subject of future interest.

While dual compartment monitoring tracked ECF and intravascular changes during dialysis, the prospect of having a biochemical parameter to mirror these changes or just be tightly correlated with the prevailing hydration status was explored as described in the latter part of this thesis. Two candidate peptides were identified that had been extensively studied in health and disease. ANP was measured and its behaviour analysed during various dialysis sessions. BNP was initially studied but remained insensitive to volume changes with a variable rate of secretion determined predominantly presumably by cardiac disease. If so, even subclinical cardiac disease was identified by raised BNP concentrations in otherwise asymptomatic dialysis patients active on the transplant list. The investigator had used the Triage BNP meter as a bedside test to measure carboxy terminal BNP. This was the first instance of its use in the dialysis population in the UK.

Carboxy terminal ANP (cANP) was measured during isovolemic dialysis during isolated UF and during dialysis with UF. A significant decrease in concentrations occurred after dialysis without UF, implying dialyser clearance. A delayed decrease in concentrations occurred after isolated UF hinting at an on-off mechanism for its secretion in response to fluid changes. This was further explored by frequent sampling during a dialysis session in an overtly fluid overloaded patient and in a subject who was euvolemic. UF caused a significant decrease in ANP concentrations that rebounded back in the interdialytic period. Further changes in ANP concentrations during dialysis in other studies hinted at a strong correlation between blood volume rebounds and rises in ANP post-dialysis. Following stabilisation of the blood volume rebound, ANP concentrations also plateau at around 80 minutes post dialysis. A significant implication of this change is that mathematical modelling could be developed to 'predict' this rebound value from the immediate post-HD ANP concentrations. This needs to be explored in future research.

Many of the hypotheses outlined at the outset have been addressed. In particular:

1. Continuous segmental bioimpedance has been shown to provide an accurate reflection of the ECF volume, not significantly affected by changes in dialysate composition, temperature or changes in posture. Changes have been identified during isovolemic dialysis which need to be

explored in future studies. Absolute values of R_{ECF} cannot be compared between studies even within the same patient.

2. Dual compartment monitoring has been shown to be a promising technique in monitoring fluid removal during haemodialysis.
3. Pulse ultrafiltration, whilst not a useful clinical tool, may be of use in revealing subtle differences in haemodynamic parameters at different points in the dialysis session.
4. ANP levels (but not BNP levels) fall in response to ultrafiltration and rebound in association with refilling of the intravascular compartment following cessation of dialysis. As such ANP levels may be a useful marker of volume status in dialysis patients, and merit further studies.

In summary, the investigator has developed a fluid management tool involving dual compartment monitoring using RBV-CSBIS which shows promise for real-time use in clinical settings. The thesis also outlines a possible role for ANP as a biochemical marker of fluid state. These ideas need to be taken forward in future research. Similar efforts should be undertaken to streamline and improve the concept of 'Refill Ratio' and define with greater clarity, ECF changes induced by isovolemic dialysis.

Reference List

Reference List

1. UK Renal Registry The Eleventh Annual Report December 2008
Ansell, D. Feehally, J. Fogarty, D. Ford, D. Hodson, A. Tomson C.V. Udayaraj, U. Warwick, G. Williams, A.
2. Graham, T. Liquid diffusion applied to analysis. *Phil Trans Roy Soc London* 151:183, 1861
3. Abel JJ, Rowntree LG, Turner BB: On the removal of diffusible substances from the circulating blood by means of dialysis. *Transactions of the Association of American Physicians*, 1913. *Transfus Sci* 1990;11:164-165.
4. Benedum J: [The early history of the artificial kidney]. *Anesthesiol Intensivmed Notfallmed Schmerzther* 2003;38:681-688.
5. Kolff WJ, Berk HT, ter Welle M, van der LEY AJ, van Dijk EC, van Noordwijk J: The artificial kidney: a dialyser with a great area. 1944. *J Am Soc Nephrol* 1997;8:1959-1965.
6. Kolff WJ: Three decades of hemodialysis. *Biomater Med Devices Artif Organs* 1974;2:189-206.
7. Kolff WJ: Artificial kidneys in the seventies. *Nephron* 1972;9:257-274.
8. Kolff WJ: Hemodialysis in the management of renal disease. *Annu Rev Med* 1972;23:321-332.
9. Wing AJ, Curtis JR, De Wardener HE: Reduction of clotting in Scribner shunts by long-term anticoagulation. *Br Med J* 1967;3:143-145.
10. Hach W, Brass H: [Experiences in the performance of the Scribner-Quinton shunt for extracorporeal dialysis]. *Med Welt* 1966;16:874-877.
11. Scribner BH, FERGUS EB, BOEN ST, THOMAS ED: SOME THERAPEUTIC APPROACHES TO CHRONIC RENAL INSUFFICIENCY. *Annu Rev Med* 1965;16:285-300.
12. Scribner BH: Maintenance hemodialysis in perspective--1969. *Helv Med Acta Suppl* 1969;49:100-108.
13. Scribner BH, Caner JE, Buri R, QUINTON W: The technique of continuous hemodialysis. *Trans Am Soc Artif Intern Organs* 1960;6:88-103.
14. Evans DB, Clarkson EM, Curtis JR: Blood loss using the modified two-layer Kiil dialyser. *Br Med J* 1967;4:651-653.
15. McMillan R, Evans DB: Experience with three Brescia-Cimino shunts. *Br Med J* 1968;3:781-783.

16. Brescia MJ, Cimino JE, Appel K, Hurwicz BJ: Chronic hemodialysis using venipuncture and a surgically created arteriovenous fistula. *N Engl J Med* 1966;275:1089-1092.
17. Solling J, Hansen HE: Comparison of a new parallel-flow, plate dialyser and a hollow fibre dialyser. *Scand J Urol Nephrol* 1979;13:305-307.
18. Vienken J, Diamantoglou M, Henne W, Nederlof B: Artificial dialysis membranes: from concept to large scale production. *Am J Nephrol* 1999;19:355-362.
19. Blagg CR, Hickman RO, Eschbach JW, Scribner BH: Home hemodialysis: six years' experience. *N Engl J Med* 1970;283:1126-1131.
20. Eschbach JW, Jr., Wilson WE, Jr., Peoples RW, Wakefield AW, Babb AL, Scribner BH: Unattended overnight home hemodialysis. *Trans Am Soc Artif Intern Organs* 1966;12:346-356.
21. Blagg CR, Hickman RO, Eschbach JW, Scribner BH: Home hemodialysis: six years' experience. *N Engl J Med* 1970;283:1126-1131.
22. Bower JD, Berman LB, Remmers R, Babb AL, Scribner BH, Gotch FA, DePalma JR, Siegel L: What is adequate dialysis? *Proc Clin Dial Transplant Forum* 1971;1:61-72.
23. Tenckhoff H, Sawyer T, Sherrard D, Scribner BH: [Rehabilitation of 240 patients with kidney diseases in a home dialysis program]. *Fortschr Med* 1972;90:833-836.
24. Barber S, Appleton DR, Kerr DN: Adequate dialysis. *Nephron* 1975;14:209-227.
25. Gotch FA, Sargent JA: A mechanistic analysis of the National Cooperative Dialysis Study (NCDS). *Kidney Int* 1985;28:526-534.
26. Sargent JA: Control of dialysis by a single-pool urea model: the National Cooperative Dialysis Study. *Kidney Int Suppl* 1983;S19-S25.
27. Lowrie EG, Teehan BP: Principles of prescribing dialysis therapy: implementing recommendations from the National Cooperative Dialysis Study. *Kidney Int Suppl* 1983;S113-S122.
28. Laird NM, Berkey CS, Lowrie EG: Modeling success or failure of dialysis therapy: the National Cooperative Dialysis Study. *Kidney Int Suppl* 1983;S101-S106.
29. Lowrie EG: History and organization of the National Cooperative Dialysis Study. *Kidney Int Suppl* 1983;S1-S7.
30. Depner TA: Optimizing the treatment of the dialysis patient: a painful lesson. *Semin Nephrol* 1997;17:285-297.
31. Parker TF, III: Role of dialysis dose on morbidity and mortality in maintenance hemodialysis patients. *Am J Kidney Dis* 1994;24:981-989.
32. Ijelu G, Goldstein M, Raja RM: Kt/V and hemodialysis morbidity revisited. *ASAIO Trans* 1990;36:M152-M154.

33. Levine J, Bernard DB: The role of urea kinetic modeling, TACurea, and Kt/V in achieving optimal dialysis: a critical reappraisal. *Am J Kidney Dis* 1990;15:285-301.
34. Keshaviah PR, Nolph KD, Van Stone JC: The peak concentration hypothesis: a urea kinetic approach to comparing the adequacy of continuous ambulatory peritoneal dialysis (CAPD) and hemodialysis. *Perit Dial Int* 1989;9:257-260.
35. Gotch FA, Sargent JA: A mechanistic analysis of the National Cooperative Dialysis Study (NCDS). *Kidney Int* 1985;28:526-534.
36. Owen WF, Jr., Chertow GM, Lazarus JM, Lowrie EG: Dose of hemodialysis and survival: differences by race and sex. *JAMA* 1998;280:1764-1768.
37. Lowrie EG, Chertow GM, Lew NL, Lazarus JM, Owen WF: The urea [clearance x dialysis time] product (Kt) as an outcome-based measure of hemodialysis dose. *Kidney Int* 1999;56:729-737.
38. Szczech LA, Lowrie EG, Li Z, Lew NL, Lazarus JM, Owen WF, Jr.: Changing hemodialysis thresholds for optimal survival. *Kidney Int* 2001;59:738-745.
39. Held PJ, Port FK, Wolfe RA, Stannard DC, Carroll CE, Daugirdas JT, Bloembergen WE, Greer JW, Hakim RM: The dose of hemodialysis and patient mortality. *Kidney Int* 1996;50:550-556.
40. Port FK, Orzol SM, Held PJ, Wolfe RA: Trends in treatment and survival for hemodialysis patients in the United States. *Am J Kidney Dis* 1998;32:S34-S38.
41. Port FK, Pisoni RL, Bragg-Gresham JL, Satayathum SS, Young EW, Wolfe RA, Held PJ: DOPPS estimates of patient life years attributable to modifiable hemodialysis practices in the United States. *Blood Purif* 2004;22:175-180.
42. Port FK, Wolfe RA, Hulbert-Shearon TE, McCullough KP, Ashby VB, Held PJ: High dialysis dose is associated with lower mortality among women but not among men. *Am J Kidney Dis* 2004;43:1014-1023.
43. Gotch F: The basic, quantifiable parameter of dialysis prescription is Kt/V urea; treatment time is determined by the ultrafiltration requirement; all three parameters are of equal importance. *Blood Purif* 2007;25:18-26.
44. Charra B: Improving adequacy improves haemodialysis outcome. *EDTNA ERCA J* 2000;26:6-10, 19.
45. Canaud B: [Adequate dialysis revisited]. *Nephrologie* 1995;16:393-397.
46. Shaldon S: Unanswered questions pertaining to dialysis adequacy in 1992. *Kidney Int Suppl* 1993;41:S274-S277.
47. Charra B, Calemard E, Chazot C, Terrat JC, Vanel T, Ruffet M, Laurent G: Dose of dialysis: what index? *Blood Purif* 1992;10:13-21.
48. Gotch FA, Yarian S, Keen M: A kinetic survey of US hemodialysis prescriptions. *Am J Kidney Dis* 1990;15:511-515.

49. Levine J, Bernard DB: The role of urea kinetic modeling, TACurea, and Kt/V in achieving optimal dialysis: a critical reappraisal. *Am J Kidney Dis* 1990;15:285-301.
50. Gotch FA, Sargent JA: A mechanistic analysis of the National Cooperative Dialysis Study (NCDS). *Kidney Int* 1985;28:526-534.
51. Gotch FA, Sargent JA, Keen ML: Whither goest Kt/V? *Kidney Int Suppl* 2000;76:S3-18.
52. Tattersall JE, DeTakats D, Chamney P, Greenwood RN, Farrington K: The post-hemodialysis rebound: predicting and quantifying its effect on Kt/V. *Kidney Int* 1996;50:2094-2102.
53. Tattersall JE, Chamney P, Aldridge C, Greenwood RN: Recirculation and the post-dialysis rebound. *Nephrol Dial Transplant* 1996;11 Suppl 2:75-80.
54. Hornberger JC, Chernew M, Petersen J, Garber AM: A multivariate analysis of mortality and hospital admissions with high-flux dialysis. *J Am Soc Nephrol* 1992;3:1227-1237.
55. Koda Y, Nishi S, Miyazaki S, Haginoshita S, Sakurabayashi T, Suzuki M, Sakai S, Yuasa Y, Hirasawa Y, Nishi T: Switch from conventional to high-flux membrane reduces the risk of carpal tunnel syndrome and mortality of hemodialysis patients. *Kidney Int* 1997;52:1096-1101.
56. Altieri P, Sorba GB, Bolasco PG, Bostrom M, Asproni E, Ferrara R, Bolasco F, Cossu M, Cadinu F, Cabiddu GF, Casu D, Ganadu M, Passaghe M, Pinna M: On-line predilution hemofiltration versus ultrapure high-flux hemodialysis: a multicenter prospective study in 23 patients. Sardinian Collaborative Study Group of On-Line Hemofiltration. *Blood Purif* 1997;15:169-181.
57. Locatelli F, Andrulli S, Pecchini F, Pedrini L, Agliata S, Lucchi L, Farina M, La M, V, Grassi C, Borghi M, Redaelli B, Conte F, Ratto G, Cabiddu G, Grossi C, Modenese R: Effect of high-flux dialysis on the anaemia of haemodialysis patients. *Nephrol Dial Transplant* 2000;15:1399-1409.
58. Woods HF, Nandakumar M: Improved outcome for haemodialysis patients treated with high-flux membranes. *Nephrol Dial Transplant* 2000;15 Suppl 1:36-42.
59. Locatelli F, Pozzoni P, Manzoni C, DI FS: High-flux hemodialysis and hemodiafiltration. Impact on outcome. *Contrib Nephrol* 2002;193-200.
60. Vanholder RC, Glorieux GL, De Smet RV: Back to the future: middle molecules, high flux membranes, and optimal dialysis. *Hemodial Int* 2003;7:52-57.
61. Santoro A, Mancini E, Bolzani R, Boggi R, Cagnoli L, Francioso A, Fusaroli M, Piazza V, Rapana R, Strippoli GF: The effect of on-line high-flux hemofiltration versus low-flux hemodialysis on mortality in chronic kidney failure: a small randomized controlled trial. *Am J Kidney Dis* 2008;52:507-518.
62. Eknayan G, Beck GJ, Cheung AK, Daugirdas JT, Greene T, Kusek JW, Allon M, Bailey J, Delmez JA, Depner TA, Dwyer JT, Levey AS, Levin NW, Milford E, Ornt DB, Rocco MV, Schulman G, Schwab SJ, Teehan BP, Toto R: Effect of dialysis dose and membrane flux in maintenance hemodialysis. *N Engl J Med* 2002;347:2010-2019.

63. Depner T, Daugirdas J, Greene T, Allon M, Beck G, Chumlea C, Delmez J, Gotch F, Kusek J, Levin N, Macon E, Milford E, Owen W, Star R, Toto R, Eknoyan G: Dialysis dose and the effect of gender and body size on outcome in the HEMO Study. *Kidney Int* 2004;65:1386-1394.
64. Cheung AK, Levin NW, Greene T, Agodoa L, Bailey J, Beck G, Clark W, Levey AS, Leypoldt JK, Ornt DB, Rocco MV, Schulman G, Schwab S, Teehan B, Eknoyan G: Effects of high-flux hemodialysis on clinical outcomes: results of the HEMO study. *J Am Soc Nephrol* 2003;14:3251-3263.
65. Ayli M, Ayli D, Azak A, Yuksel C, Atilgan G, Dede F, Akalin T, Abayli E, Camlibel M: The effect of high-flux hemodialysis on dialysis-associated amyloidosis. *Ren Fail* 2005;27:31-34.
66. Locatelli F, Pozzoni P, Di FS: What are we expecting to learn from the MPO study? *Contrib Nephrol* 2005;149:83-89.
67. Locatelli F, Gaulty A, Czekalski S, Hannedouche T, Jacobson SH, Loureiro A, Martin-Malo A, Papadimitriou M, Passlick-Deetjen J, Ronco C, Vanholder R, Wizemann V: The MPO Study: just a European HEMO Study or something very different? *Blood Purif* 2008;26:100-104.
68. Charra B, Calemard E, Cuhe M, Laurent G: Control of hypertension and prolonged survival on maintenance hemodialysis. *Nephron* 1983;33:96-99.
69. Komenda P, Copland M, Er L, Djurdjev O, Levin A: Outcomes of a provincial home haemodialysis programme--a two-year experience: establishing benchmarks for programme evaluation. *Nephrol Dial Transplant* 2008;23:2647-2652.
70. Ansell D: Home haemodialysis: Missing facts, different countries. *BMJ* 2008;336:172-173.
71. Bergman A, Fenton SS, Richardson RM, Chan CT: Reduction in cardiovascular related hospitalization with nocturnal home hemodialysis. *Clin Nephrol* 2008;69:33-39.
72. Oreopoulos DG, Thodis E, Passadakis P, Vargemezis V: Home dialysis as a first option: a new paradigm. *Int Urol Nephrol* 2009.
73. Agar JW: International variations and trends in home hemodialysis. *Adv Chronic Kidney Dis* 2009;16:205-214.
74. Rocco MV: Short daily and nocturnal hemodialysis: new therapies for a new century? *Saudi J Kidney Dis Transpl* 2009;20:1-11.
75. Pauly RP, Asad RA, Hanley JA, Pierratos A, Zaltzman J, Chery A, Chan CT: Long-term clinical outcomes of nocturnal hemodialysis patients compared with conventional hemodialysis patients post-renal transplantation. *Clin Transplant* 2009;23:47-55.
76. Goldstein SL, Silverstein DM, Leung JC, Feig DI, Soletsky B, Knight C, Warady BA: Frequent hemodialysis with NxStage system in pediatric patients receiving maintenance hemodialysis. *Pediatr Nephrol* 2008;23:129-135.
77. Zilch O, Vos PF, Oey PL, Cramer MJ, Ligtenberg G, Koomans HA, Blankestijn PJ: Sympathetic hyperactivity in haemodialysis patients is reduced by short daily haemodialysis. *J Hypertens* 2007;25:1285-1289.

78. Vallance P, Leone A, Calver A, Collier J, Moncada S: Accumulation of an endogenous inhibitor of nitric oxide synthesis in chronic renal failure. *Lancet* 1992;339:572-575.
79. MacAllister RJ, Rambausek MH, Vallance P, Williams D, Hoffmann KH, Ritz E: Concentration of dimethyl-L-arginine in the plasma of patients with end-stage renal failure. *Nephrol Dial Transplant* 1996;11:2449-2452.
80. Foley RN, Herzog CA, Collins AJ: Blood pressure and long-term mortality in United States hemodialysis patients: USRDS Waves 3 and 4 Study. *Kidney Int* 2002;62:1784-1790.
81. Gilmartin JJ, Duffy BS, Finnegan P, McCreedy N: Non invasive study of left ventricular function in chronic renal failure before and after hemodialysis. *Clin Nephrol* 1983;20:55-60.
82. Colan SD, Sanders SP, Ingelfinger JR, Harmon W: Left ventricular mechanics and contractile state in children and young adults with end-stage renal disease: effect of dialysis and renal transplantation. *J Am Coll Cardiol* 1987;10:1085-1094.
83. Charra B, Chazot C: Volume control, blood pressure and cardiovascular function. Lessons from hemodialysis treatment. *Nephron Physiol* 2003;93:94-101.
84. Foley RN, Parfrey PS, Harnett JD, Kent GM, Murray DC, Barre PE: The impact of anemia on cardiomyopathy, morbidity, and mortality in end-stage renal disease. *Am J Kidney Dis* 1996;28:53-61.
85. Foley RN, Parfrey PS: Cardiovascular disease and mortality in ESRD. *J Nephrol* 1998;11:239-245.
86. Foley RN, Parfrey PS, Morgan J, Barre PE, Campbell P, Cartier P, Coyle D, Fine A, Handa P, Kingma I, Lau CY, Levin A, Mendelssohn D, Muirhead N, Murphy B, Plante RK, Posen G, Wells GA: Effect of hemoglobin levels in hemodialysis patients with asymptomatic cardiomyopathy. *Kidney Int* 2000;58:1325-1335.
87. Lynn KL: Hypertension and survival in hemodialysis patients. *Semin Dial* 2004;17:270-274.
88. Chazot C, Charra B, Vo VC, Jean G, Vanel T, Calemard E, Terrat JC, Ruffet M, Laurent G: The Janus-faced aspect of 'dry weight'. *Nephrol Dial Transplant* 1999;14:121-124.
89. Foley RN: Cardiac disease in chronic uremia: can it explain the reverse epidemiology of hypertension and survival in dialysis patients? *Semin Dial* 2004;17:275-278.
90. Zager PG, Nikolic J, Brown RH, Campbell MA, Hunt WC, Peterson D, Van SJ, Levey A, Meyer KB, Klag MJ, Johnson HK, Clark E, Sadler JH, Teredesai P: "U" curve association of blood pressure and mortality in hemodialysis patients. *Medical Directors of Dialysis Clinic, Inc. Kidney Int* 1998;54:561-569.
91. Johnson DW, Craven AM, Isbel NM: Modification of cardiovascular risk in hemodialysis patients: an evidence-based review. *Hemodial Int* 2007;11:1-14.
92. Locatelli F, Del Vecchio L, Manzoni C: Morbidity and mortality on maintenance haemodialysis. *Nephron* 1998;80:380-400.

93. Foley RN, Parfrey PS: Cardiovascular disease and mortality in ESRD. *J Nephrol* 1998;11:239-245.
94. Liu JY, Birkmeyer NJ, Sanders JH, Morton JR, Henriques HF, Lahey SJ, Dow RW, Maloney C, DiScipio AW, Clough R, Leavitt BJ, O'Connor GT: Risks of morbidity and mortality in dialysis patients undergoing coronary artery bypass surgery. Northern New England Cardiovascular Disease Study Group. *Circulation* 2000;102:2973-2977.
95. Parfrey PS: Cardiac disease in dialysis patients: diagnosis, burden of disease, prognosis, risk factors and management. *Nephrol Dial Transplant* 2000;15 Suppl 5:58-68.
96. Charra B, Laurent G, Calemard E, Terrat JC, Vanel T, Ruffet M, Chazot C: Survival in dialysis and blood pressure control. *Contrib Nephrol* 1994;106:179-185.
97. Charra B: Dialysis time. What should it be? *ASAIO J* 1997;43:228-229.
98. Laurent G, Charra B: The results of an 8 h thrice weekly haemodialysis schedule. *Nephrol Dial Transplant* 1998;13 Suppl 6:125-131.
99. Charra B, Terrat JC, Vanel T, Chazot C, Jean G, Hurot JM, Lorriaux C: Long thrice weekly hemodialysis: the Tassin experience. *Int J Artif Organs* 2004;27:265-283.
100. Heerspink HJ, Ninomiya T, Zoungas S, de Zeeuw D, Grobbee DE, Jardine MJ, Gallagher M, Roberts MA, Cass A, Neal B, Perkovic V: Effect of lowering blood pressure on cardiovascular events and mortality in patients on dialysis: a systematic review and meta-analysis of randomised controlled trials. *Lancet* 2009;373:1009-1015.
101. Henderson LW: Symptomatic hypotension during hemodialysis. *Kidney Int* 1980;17:571-576.
102. Kouw PM, Kooman JP, Cheriex EC, Olthof CG, de Vries PM, Leunissen KM: Assessment of postdialysis dry weight: a comparison of techniques. *J Am Soc Nephrol* 1993;4:98-104.
103. Cheigh JS, Milite C, Sullivan JF, Rubin AL, Stenzel KH: Hypertension is not adequately controlled in hemodialysis patients. *Am J Kidney Dis* 1992;19:453-459.
104. Charra B, Bergstrom J, Scribner BH: Blood pressure control in dialysis patients: importance of the lag phenomenon. *Am J Kidney Dis* 1998;32:720-724.
105. Fishbane S, Natke E, Maesaka JK: Role of volume overload in dialysis-refractory hypertension. *Am J Kidney Dis* 1996;28:257-261.
106. Charra B, Calemard E, Ruffet M, Chazot C, Terrat JC, Vanel T, Laurent G: Survival as an index of adequacy of dialysis. *Kidney Int* 1992;41:1286-1291.
107. Sherman RA, Daniel A, Cody RP: The effect of interdialytic weight gain on predialysis blood pressure. *Artif Organs* 1993;17:770-774.
108. Jaeger JQ, Mehta RL: Assessment of dry weight in hemodialysis: an overview. *J Am Soc Nephrol* 1999;10:392-403.
109. Foley RN, Parfrey PS: Cardiovascular disease and mortality in ESRD. *J Nephrol* 1998;11:239-245.

110. Malatino LS, Benedetto FA, Mallamaci F, Tripepi G, Zoccali C, Parlongo S, Cutrupi S, Marino C, Panuccio V, Garozzo M, Candela V, Bellanuova I, Cataliotti A, Rapisarda F, Fatuzzo P, Bonanno G, Seminara G, Stancanelli B, Tassone F, Labate C: Smoking, blood pressure and serum albumin are major determinants of carotid atherosclerosis in dialysis patients. CREED Investigators. Cardiovascular Risk Extended Evaluation in Dialysis patients. *J Nephrol* 1999;12:256-260.
111. Ozkahya M, Ok E, Toz H, Asci G, Duman S, Basci A, Kose T, Dorhout Mees EJ: Long-term survival rates in haemodialysis patients treated with strict volume control. *Nephrol Dial Transplant* 2006;21:3506-3513.
112. Zucchelli P, Santoro A: Dry weight in hemodialysis: volemic control. *Semin Nephrol* 2001;21:286-290.
113. Blood pressure profile of prevalent patients receiving dialysis in the UK in 2007: national and centre-specific analyses : Eleventh Annual Report UK Renal Registry 2008
Janice Harper , Johann Nicholas , Daniel Ford , Anna Casula and Andrew J Williams
114. Cheung AK, Sarnak MJ, Yan G, Berkoben M, Heyka R, Kaufman A, Lewis J, Rocco M, Toto R, Windus D, Ornt D, Levey AS: Cardiac diseases in maintenance hemodialysis patients: results of the HEMO Study. *Kidney Int* 2004;65:2380-2389.
115. Manley HJ, Garvin CG, Drayer DK, Reid GM, Bender WL, Neufeld TK, Hebbbar S, Muther RS: Medication prescribing patterns in ambulatory haemodialysis patients: comparisons of USRDS to a large not-for-profit dialysis provider. *Nephrol Dial Transplant* 2004;19:1842-1848.
116. Charra B, Terrat JC, Vanel T, Chazot C, Jean G, Hurot JM, Lorriaux C: Long thrice weekly hemodialysis: the Tassin experience. *Int J Artif Organs* 2004;27:265-283.
117. Ahmad R, Goldsmith HJ: Home dialysis. *Br J Hosp Med* 1983;29:95-104.
118. Covic A, Goldsmith DJ, Venning MC, Ackrill P: Long-hours home haemodialysis--the best renal replacement therapy method? *QJM* 1999;92:251-260.
119. Charra B, Bergstrom J, Scribner BH: Blood pressure control in dialysis patients: importance of the lag phenomenon. *Am J Kidney Dis* 1998;32:720-724.
120. Khosla UM, Johnson RJ: Hypertension in the hemodialysis patient and the "lag phenomenon": insights into pathophysiology and clinical management. *Am J Kidney Dis* 2004;43:739-751.
121. Guyton AC, Coleman TG, Fourcade JC, Navar LG: Physiologic control of arterial pressure. *Bull N Y Acad Med* 1969;45:811-830.
122. Vallance P, Leone A, Calver A, Collier J, Moncada S: Endogenous dimethylarginine as an inhibitor of nitric oxide synthesis. *J Cardiovasc Pharmacol* 1992;20 Suppl 12:S60-S62.

123. MacAllister RJ, Rambausek MH, Vallance P, Williams D, Hoffmann KH, Ritz E: Concentration of dimethyl-L-arginine in the plasma of patients with end-stage renal failure. *Nephrol Dial Transplant* 1996;11:2449-2452.
124. Anderstam B, Katzarski K, Bergstrom J: Serum levels of NG, NG-dimethyl-L-arginine, a potential endogenous nitric oxide inhibitor in dialysis patients. *J Am Soc Nephrol* 1997;8:1437-1442.
125. Schroder M, Riedel E, Beck W, Deppisch RM, Pommer W: Increased reduction of dimethylarginines and lowered interdialytic blood pressure by the use of biocompatible membranes. *Kidney Int Suppl* 2001;78:S19-S24.
126. Bisordi JE, Holt S: Digitalislike immunoreactive substances and extracellular fluid volume status in chronic hemodialysis patients. *Am J Kidney Dis* 1989;13:396-403.
127. Odar-Cederlof I, Ericsson F, Theodorsson E, Kjellstrand CM: Is neuropeptide Y a contributor to volume-induced hypertension? *Am J Kidney Dis* 1998;31:803-808.
128. Schafflhuber M, Volpi N, Dahlmann A, Hilgers KF, Maccari F, Dietsch P, Wagner H, Luft FC, Eckardt KU, Titze J: Mobilization of osmotically inactive Na⁺ by growth and by dietary salt restriction in rats. *Am J Physiol Renal Physiol* 2007;292:F1490-F1500.
129. Shaldon S, Vienken J: The long forgotten salt factor and the benefits of using a 5-g-salt-restricted diet in all ESRD patients. *Nephrol Dial Transplant* 2008;23:2118-2120.
130. Ozkahya M, Ok E, Cirit M, Aydin S, Akcicek F, Basci A, Dorhout Mees EJ: Regression of left ventricular hypertrophy in haemodialysis patients by ultrafiltration and reduced salt intake without antihypertensive drugs. *Nephrol Dial Transplant* 1998;13:1489-1493.
131. Ozkahya M, Toz H, Qzerkan F, Duman S, Ok E, Basci A, Mees EJ: Impact of volume control on left ventricular hypertrophy in dialysis patients. *J Nephrol* 2002;15:655-660.
132. Ozkahya M, Ok E, Toz H, Asci G, Duman S, Basci A, Kose T, Dorhout Mees EJ: Long-term survival rates in haemodialysis patients treated with strict volume control. *Nephrol Dial Transplant* 2006;21:3506-3513.
133. Agarwal R, Alborzi P, Satyan S, Light RP: Dry-weight reduction in hypertensive hemodialysis patients (DRIP): a randomized, controlled trial. *Hypertension* 2009;53:500-507.
134. Lazarus JM, Henderson LW, Kjellstrand CM, Weiner MW, Henrich WL, Hakim RM: Cardiovascular instability during hemodialysis. *Trans Am Soc Artif Intern Organs* 1982;28:656-665.
135. Jameson MD, Wiegmann TB: Principles, uses, and complications of hemodialysis. *Med Clin North Am* 1990;74:945-960.
136. Leypoldt JK, Cheung AK: Evaluating volume status in hemodialysis patients. *Adv Ren Replace Ther* 1998;5:64-74.
137. Lynn KL: Hypertension and survival in hemodialysis patients. *Semin Dial* 2004;17:270-274.

138. Shoji T, Tsubakihara Y, Fujii M, Imai E: Hemodialysis-associated hypotension as an independent risk factor for two-year mortality in hemodialysis patients. *Kidney Int* 2004;66:1212-1220.
139. Ori Y, Chagnac A, Schwartz A, Herman M, Weinstein T, Zevin D, Gafter U, Korzets A: Non-occlusive mesenteric ischemia in chronically dialyzed patients: a disease with multiple risk factors. *Nephron Clin Pract* 2005;101:c87-c93.
140. Relex control of veins and vascular capacitance
Rothe CF: *Physiol Rev* 63:1281-1342, 1983
141. Shen YT, Knight DR, Thomas JX JR, Vatner SF: Relative roles of cardiac receptors and arterial baroreceptors during haemorrhage in conscious dogs *Circ Research* 66:397-405, 1990
142. Pierratos A, Ouwendyk M, Francoeur R, Vas S, Raj DS, Ecclestone AM, Langos V, Uldall R: Nocturnal hemodialysis: three-year experience. *J Am Soc Nephrol* 1998;9:859-868.
143. Pierratos A: Nocturnal home haemodialysis: an update on a 5-year experience. *Nephrol Dial Transplant* 1999;14:2835-2840.
144. Pierratos A: Nocturnal hemodialysis: dialysis for the new millennium. *CMAJ* 1999;161:1137.
145. Foley RN, Parfrey PS, Harnett JD, Kent GM, Martin CJ, Murray DC, Barre PE: Clinical and echocardiographic disease in patients starting end-stage renal disease therapy. *Kidney Int* 1995;47:186-192.
146. Parfrey PS, Harnett JD, Barre PE: The natural history of myocardial disease in dialysis patients. *J Am Soc Nephrol* 1991;2:2-12.
147. Liu JY, Birkmeyer NJ, Sanders JH, Morton JR, Henriques HF, Lahey SJ, Dow RW, Maloney C, DiScipio AW, Clough R, Leavitt BJ, O'Connor GT: Risks of morbidity and mortality in dialysis patients undergoing coronary artery bypass surgery. Northern New England Cardiovascular Disease Study Group. *Circulation* 2000;102:2973-2977.
148. Nette RW, Akcahuseyin E, Krepel HP, Weimar W, Zietse R: Increase in blood volume during dialysis without ultrafiltration. *Blood Purif* 2001;19:33-38.
149. Tomson CR: Blood pressure and outcome in patients on dialysis. *Lancet* 2009;373:981-982.
150. Locatelli F, Buoncristiani U, Canaud B, Kohler H, Petitclerc T, Zucchelli P: Haemodialysis with on-line monitoring equipment: tools or toys? *Nephrol Dial Transplant* 2005;20:22-33.
151. Kaczmarczyk I, Krasniak A, Drozd M, Chowanec E, Gajda M, Radziszewski A, Sulowicz W: The influence of sodium profiling on blood volume and intradialytic hypotension in patients on maintenance hemodialysis. *Przegl Lek* 2007;64:476-482.
152. Doulton TW, MacGregor GA: Blood pressure in haemodialysis patients: the importance of the relationship between the renin-angiotensin-aldosterone system, salt intake and extracellular volume. *J Renin Angiotensin Aldosterone Syst* 2004;5:14-22.

153. Spittle MA, Hoenich NA, Handelman GJ, Adhikarla R, Homel P, Levin NW: Oxidative stress and inflammation in hemodialysis patients. *Am J Kidney Dis* 2001;38:1408-1413.
154. Rysz J, Banach M, Cialkowska-Rysz A, Stolarek R, Barylski M, Drozd J, Okonski P: Blood serum levels of IL-2, IL-6, IL-8, TNF-alpha and IL-1beta in patients on maintenance hemodialysis. *Cell Mol Immunol* 2006;3:151-154.
155. Yokokawa K, Mankus R, Saklayen MG, Kohno M, Yasunari K, Minami M, Kano H, Horio T, Takeda T, Mandel AK: Increased nitric oxide production in patients with hypotension during hemodialysis. *Ann Intern Med* 1995;123:35-37.
156. Arizono K, Nomura K, Motoyama T, Matsushita Y, Matsuoka K, Miyazu R, Takeshita H, Fukui H: Use of ultrapure dialysate in reduction of chronic inflammation during hemodialysis. *Blood Purif* 2004;22 Suppl 2:26-29.
157. Bruges M, Barata JD, Oliveira C, Furstenau C, Gomes EM, Simoes J: [Hemodialysis with bicarbonate 30 mEq/l versus 34 mEq/l and acetate: better hemodynamic tolerance and electrolyte and acid-base homeostasis]. *Acta Med Port* 1994;7:165-170.
158. Sivalingam M, Banerjee A, Nevet G, Farrington K: Haemodynamic effects of food intake during haemodialysis. *Blood Purif* 2008;26:157-162.
159. Rowell LB: Control of individual vascular beds: Splanchnic and renal circulations (Chapter 4) in, *The Human Circulation- Regulation during Physical Stress* New York, Oxford University Press, 1986, p85
160. Daugirdas JT: Dialysis hypotension: a hemodynamic analysis. *Kidney Int* 1991;39:233-246.
161. Franssen CF: Adenosine and dialysis hypotension. *Kidney Int* 2006;69:789-791.
162. Converse RL, Jr., Jacobsen TN, Toto RD, Jost CM, Cosentino F, Fouad-Tarazi F, Victor RG: Sympathetic overactivity in patients with chronic renal failure. *N Engl J Med* 1992;327:1912-1918.
163. Converse RL, Jr., Jacobsen TN, Jost CM, Toto RD, Grayburn PA, Obregon TM, Fouad-Tarazi F, Victor RG: Paradoxical withdrawal of reflex vasoconstriction as a cause of hemodialysis-induced hypotension. *J Clin Invest* 1992;90:1657-1665.
164. Daugirdas JT: Pathophysiology of dialysis hypotension: an update. *Am J Kidney Dis* 2001;38:S11-S17.
165. Zuber M, Steinmann E, Huser B, Ritz R, Thiel G, Brunner F: Incidence of arrhythmias and myocardial ischaemia during haemodialysis and haemofiltration. *Nephrol Dial Transplant* 1989;4:632-634.
166. Abe S, Yoshizawa M, Nakanishi N, Yazawa T, Yokota K, Honda M, Sloman G: Electrocardiographic abnormalities in patients receiving hemodialysis. *Am Heart J* 1996;131:1137-1144.
167. Cice G, Di BA, D'Andrea A, D'Isa S, De GP, Marcelli D, Gatti E, Calabro R: Heart rate as independent prognostic factor for mortality in normotensive hemodialysed patients. *J Nephrol* 2008;21:704-712.

168. Mohi-ud-din K, Bali HK, Banerjee S, Sakhuja V, Jha V: Silent myocardial ischemia and high-grade ventricular arrhythmias in patients on maintenance hemodialysis. *Ren Fail* 2005;27:171-175.
169. Croitoru M, Taegtmeier H: Spurious rises in troponin T in end-stage renal disease. *Lancet* 1995;346:974.
170. Porter GA, Norton T, Bennett WB: Troponin T, a predictor of death in chronic haemodialysis patients. *Eur Heart J* 1998;19 Suppl N:N34-N37.
171. Choy JB, Armstrong PW, Ulan RA, Campbell PM, Gourishankar S, Prosser CI, Tymchak WJ: Do cardiac troponins provide prognostic insight in hemodialysis patients? *Can J Cardiol* 2003;19:907-911.
172. Fehr T, Knoflach A, Ammann P, Pei P, Binswanger U: Differential use of cardiac troponin T versus I in hemodialysis patients. *Clin Nephrol* 2003;59:35-39.
173. Vichairuangthum K, Leowattana W, Ong-Ajyooth L, Pokum S: The relationship between serum concentration of cardiac troponin I in chronic renal failure patients and cardiovascular events. *J Med Assoc Thai* 2006;89:714-720.
174. Hickman PE, Koerbin G, Southcott E, Tate J, Dimeski G, Carter A, McGill D, Talaulikar G, Potter JM: Newer cardiac troponin I assays have similar performance to troponin T in patients with end-stage renal disease. *Ann Clin Biochem* 2007;44:285-289.
175. Petrovic D, Obrenovic R, Stojimirovic B: Cardiac troponins and left ventricular hypertrophy in hemodialysis patients. *Clin Lab* 2008;54:145-152.
176. Roberts MA, Hare DL, Macmillan N, Ratnaike S, Sikaris K, Ierino FL: Serial increased cardiac troponin T predicts mortality in asymptomatic patients treated with chronic haemodialysis. *Ann Clin Biochem* 2009.
177. Singh N, Langer A, Freeman MR, Goldstein MB: Myocardial alterations during hemodialysis: insights from new noninvasive technology. *Am J Nephrol* 1994;14:173-181.
178. Selby NM, Lambie SH, Camici PG, Baker CS, McIntyre CW: Occurrence of regional left ventricular dysfunction in patients undergoing standard and biofeedback dialysis. *Am J Kidney Dis* 2006;47:830-841.
179. Selby NM, McIntyre CW: The acute cardiac effects of dialysis. *Semin Dial* 2007;20:220-228.
180. McIntyre CW, Burton JO, Selby NM, Leccisotti L, Korsheed S, Baker CS, Camici PG: Hemodialysis-induced cardiac dysfunction is associated with an acute reduction in global and segmental myocardial blood flow. *Clin J Am Soc Nephrol* 2008;3:19-26.
181. Burton JO, Jefferies HJ, Selby NM, McIntyre CW: Hemodialysis-induced cardiac injury: determinants and associated outcomes. *Clin J Am Soc Nephrol* 2009;4:914-920.
182. Dasselaar JJ, Slart RH, Knip M, Pruijm J, Tio RA, McIntyre CW, DE Jong PE, Franssen CF: Haemodialysis is associated with a pronounced fall in myocardial perfusion. *Nephrol Dial Transplant* 2009;24:604-610.

183. Sarkar SR, Kotanko P, Levin NW: Interdialytic weight gain: implications in hemodialysis patients. *Semin Dial* 2006;19:429-433.
184. Charra B, Chazot C, Jean G, Laurent G: Long, slow dialysis. *Miner Electrolyte Metab* 1999;25:391-396.
185. Chen W, Cheng LT, Wang T: Salt and fluid intake in the development of hypertension in peritoneal dialysis patients. *Ren Fail* 2007;29:427-432.
186. Sivalingam M, Banerjee A, Nevett G, Farrington K: Haemodynamic effects of food intake during haemodialysis. *Blood Purif* 2008;26:157-162.
187. Shibagaki Y, Takaichi K: Significant reduction of the large-vessel blood volume by food intake during hemodialysis. *Clin Nephrol* 1998;49:49-54.
188. Shibagaki Y, Takaichi K: Significant reduction of the large-vessel blood volume by food intake during hemodialysis. *Clin Nephrol* 1998;49:49-54.
189. Charra B, Bergstrom J, Scribner BH: Blood pressure control in dialysis patients: importance of the lag phenomenon. *Am J Kidney Dis* 1998;32:720-724.
190. Williams AJ, Ford D, Casula A, Tomson CR: UK Renal Registry 11th Annual Report (December 2008): Chapter 8 Adequacy of haemodialysis in UK renal centres in 2007: national and centre-specific analyses. *Nephron Clin Pract* 2009;111 Suppl 1:c141-c147.
191. McKane W, Chandna SM, Tattersall JE, Greenwood RN, Farrington K: Identical decline of residual renal function in high-flux biocompatible hemodialysis and CAPD. *Kidney Int* 2002;61:256-265.
192. Vilar E, Wellsted D, Chandna SM, Greenwood RN, Farrington K: Residual renal function improves outcome in incremental haemodialysis despite reduced dialysis dose. *Nephrol Dial Transplant* 2009.
193. Bragg-Gresham JL, Fissell RB, Mason NA, Bailie GR, Gillespie BW, Wizemann V, Cruz JM, Akiba T, Kurokawa K, Ramirez S, Young EW: Diuretic use, residual renal function, and mortality among hemodialysis patients in the Dialysis Outcomes and Practice Pattern Study (DOPPS). *Am J Kidney Dis* 2007;49:426-431.
194. Gunal AI, Kirciman E, Guler M, Yavuzkir M, Celiker H: Should the preservation of residual renal function cost volume overload and its consequence left ventricular hypertrophy in new hemodialysis patients? *Ren Fail* 2004;26:405-409.
195. Thomson GE, Waterhouse K, McDonald HP, Jr., Friedman EA: Hemodialysis for chronic renal failure. Clinical observations. *Arch Intern Med* 1967;120:153-167.
196. Charra B, Laurent G, Chazot C, Calemard E, Terrat JC, Vanel T, Jean G, Ruffet M: Clinical assessment of dry weight. *Nephrol Dial Transplant* 1996;11 Suppl 2:16-19.
197. Verdecchia P, Schillaci G, Porcellati C: Dippers versus non-dippers. *J Hypertens Suppl* 1991;9:S42-S44.

198. Verdecchia P, Porcellati C, Schillaci G, Borgioni C, Ciucci A, Battistelli M, Guerrieri M, Gatteschi C, Zampi I, Santucci A, .: Ambulatory blood pressure. An independent predictor of prognosis in essential hypertension. *Hypertension* 1994;24:793-801.
199. Clement DL: Ambulatory blood pressure recordings. *Acta Cardiol* 1987;42:237-241.
200. Bobrie G, Genes N, Vaur L, Clerson P, Vaisse B, Mallion JM, Chatellier G: Is "isolated home" hypertension as opposed to "isolated office" hypertension a sign of greater cardiovascular risk? *Arch Intern Med* 2001;161:2205-2211.
201. Agarwal R, Andersen MJ: Prognostic importance of ambulatory blood pressure recordings in patients with chronic kidney disease. *Kidney Int* 2006;69:1175-1180.
202. Coomer RW, Schulman G, Breyer JA, Shyr Y: Ambulatory blood pressure monitoring in dialysis patients and estimation of mean interdialytic blood pressure. *Am J Kidney Dis* 1997;29:678-684.
203. Mitra S, Chandna SM, Farrington K: What is hypertension in chronic haemodialysis? The role of interdialytic blood pressure monitoring. *Nephrol Dial Transplant* 1999;14:2915-2921.
204. Agarwal R, Alborzi P, Satyan S, Light RP: Dry-weight reduction in hypertensive hemodialysis patients (DRIP): a randomized, controlled trial. *Hypertension* 2009;53:500-507.
205. Agarwal R, Satyan S, Alborzi P, Light RP, Tegegne GG, Mazengia HS, Yigazu PM: Home Blood Pressure Measurements for Managing Hypertension in Hemodialysis Patients. *Am J Nephrol* 2009;30:126-134.
206. Huting J, Kramer W, Schutterle G, Wizemann V: Analysis of left-ventricular changes associated with chronic hemodialysis. A noninvasive follow-up study. *Nephron* 1988;49:284-290.
207. Foley RN, Parfrey PS, Harnett JD, Kent GM, Martin CJ, Murray DC, Barre PE: Clinical and echocardiographic disease in patients starting end-stage renal disease therapy. *Kidney Int* 1995;47:186-192.
208. Parfrey PS, Harnett JD: Long-term cardiac morbidity and mortality during dialysis therapy. *Adv Nephrol Necker Hosp* 1994;23:311-330.
209. Ultrasonographic evaluation of changes in the inferior vena cava configuration during hemodialysis: ...
Y Ando, K Tabei, A Shiina, Y Asano, S Hosoda - *J Jpn Soc Dial Therapy*, 1985
210. Ando Y, Yanagiba S, Asano Y: The inferior vena cava diameter as a marker of dry weight in chronic hemodialyzed patients. *Artif Organs* 1995;19:1237-1242.
211. Cheriex EC, Leunissen KM, Janssen JH, Mooy JM, van Hooff JP: Echography of the inferior vena cava is a simple and reliable tool for estimation of 'dry weight' in haemodialysis patients. *Nephrol Dial Transplant* 1989;4:563-568.
212. Katzarski KS, Nisell J, Randmaa I, Danielsson A, Freyschuss U, Bergstrom J: A critical evaluation of ultrasound measurement of inferior vena cava diameter in assessing dry weight in normotensive and hypertensive hemodialysis patients. *Am J Kidney Dis* 1997;30:459-465.

213. Naruse M, Sakaguchi S, Nakayama Y, Nonoguchi H, Tomita K: A novel method for dry weight assessment in hemodialysis patients: utilization of inferior vena cava flat ratio to correct for individual variations in vessel diameter. *Ther Apher Dial* 2007;11:42-48.
214. Yashiro M, Kamata T, Yamadori N, Tomita M, Muso E: Evaluation of markers to estimate volume status in hemodialysis patients: atrial natriuretic peptide, inferior vena cava diameter, blood volume changes and filtration coefficients of microvasculature. *Ther Apher Dial* 2007;11:131-137.
215. Mandelbaum A, Ritz E: Vena cava diameter measurement for estimation of dry weight in haemodialysis patients. *Nephrol Dial Transplant* 1996;11 Suppl 2:24-27.
216. Lee SW, Song JH, Kim GA, Lim HJ, Kim MJ: Plasma brain natriuretic peptide concentration on assessment of hydration status in hemodialysis patient. *Am J Kidney Dis* 2003;41:1257-1266.
217. Leunissen KM, Menheere PP, Cheriex EC, van den Berg BW, Noordzij TC, van Hooff JP: Plasma alpha-human atrial natriuretic peptide and volume status in chronic haemodialysis patients. *Nephrol Dial Transplant* 1989;4:382-386.
218. Mitra S, Chamney P, Greenwood R, Farrington K: Serial determinations of absolute plasma volume with indocyanine green during hemodialysis. *J Am Soc Nephrol* 2003;14:2345-2351.
219. Stiller S, Schallenberg U, Gladziwa U, Ernst E, Mann H: Short time dialysis with continuous blood volume control. *Int J Artif Organs* 1990;13:83-86.
220. Schneditz D, Poggitsch H, Horina J, Binswanger U: A blood protein monitor for the continuous measurement of blood volume changes during hemodialysis. *Kidney Int* 1990;38:342-346.
221. De Vries JP, Olthof CG, Visser V, Kouw PM, van EA, Donker JM, De Vries PM: Continuous measurement of blood volume during hemodialysis by an optical method. *ASAIO J* 1992;38:M181-M185.
222. Steuer RR, Harris DH, Weiss RL, Biddulph MC, Conis JM: Evaluation of a noninvasive hematocrit monitor: a new technology. *Am Clin Lab* 1991;10:20-22.
223. Kim KE, Neff M, Cohen B, Somerstein M, Chinitz J, Onesti G, Swartz C: Blood volume changes and hypotension during hemodialysis. *Trans Am Soc Artif Intern Organs* 1970;16:508-514.
224. Steuer RR, Leypoldt JK, Cheung AK, Harris DH, Conis JM: Hematocrit as an indicator of blood volume and a predictor of intradialytic morbid events. *ASAIO J* 1994;40:M691-M696.
225. De Vries JP, Bogaard HJ, Kouw PM, Oe LP, Stevens P, De Vries PM: The adjustment of post dialytic dry weight based on non-invasive measurement of extracellular fluid and blood volumes. *ASAIO J* 1993;39:M368-M372.
226. Santoro A, Mancini E, Paolini F, Cavicchioli G, Bosetto A, Zucchelli P: Blood volume regulation during hemodialysis. *Am J Kidney Dis* 1998;32:739-748.
227. Beige J, Sone J, Sharma AM, Rudwaleit M, Offermann G, Distler A, Preuschhof L: Computational analysis of blood volume curves and risk of intradialytic morbid events in hemodialysis. *Kidney Int* 2000;58:1805-1809.

228. Mitra S, Chamney P, Greenwood R, Farrington K: Linear decay of relative blood volume during ultrafiltration predicts hemodynamic instability. *Am J Kidney Dis* 2002;40:556-565.
229. Andrulli S, Colzani S, Mascia F, Lucchi L, Stipo L, Bigi MC, Crepaldi M, Redaelli B, Albertazzi A, Locatelli F: The role of blood volume reduction in the genesis of intradialytic hypotension. *Am J Kidney Dis* 2002;40:1244-1254.
230. Rodriguez HJ, Domenici R, Diroll A, Goykhman I: Assessment of dry weight by monitoring changes in blood volume during hemodialysis using Crit-Line. *Kidney Int* 2005;68:854-861.
231. Reddan DN, Szczech LA, Hasselblad V, Lowrie EG, Lindsay RM, Himmelfarb J, Toto RD, Stivelman J, Winchester JF, Zillman LA, Califf RM, Owen WF, Jr.: Intradialytic blood volume monitoring in ambulatory hemodialysis patients: a randomized trial. *J Am Soc Nephrol* 2005;16:2162-2169.
232. Lopot F, Kotyk P, Forejt J: [Determination of dry weight of hemodialyzed patients on the basis of the ratio of extracellular fluid volume to total body fluid volume as measured by multifrequency impedance]. *Vnitr Lek* 1995;41:753-758.
233. Santoro A, Mancini E, Paolini F, Spongano M, Zucchelli P: Automatic control of blood volume trends during hemodialysis. *ASAIO J* 1994;40:M419-M422.
234. Ronco C, Brendolan A, Milan M, Rodeghiero MP, Zanella M, La GG: Impact of biofeedback-induced cardiovascular stability on hemodialysis tolerance and efficiency. *Kidney Int* 2000;58:800-808.
235. Basile C, Giordano R, Vernaglione L, Montanaro A, De MP, De PF, Marangi AL, Di ML, Santese D, Semeraro A, Ligorio VA: Efficacy and safety of haemodialysis treatment with the Hemocontrol biofeedback system: a prospective medium-term study. *Nephrol Dial Transplant* 2001;16:328-334.
236. Franssen CF, Dasselaar JJ, Sytsma P, Burgerhof JG, DE Jong PE, Huisman RM: Automatic feedback control of relative blood volume changes during hemodialysis improves blood pressure stability during and after dialysis. *Hemodial Int* 2005;9:383-392.
237. Boer W, Claus M, Cremaschi L et al. Less intradialytic complications with blood volume control [abstract]. *Nephrol Dial Transplant* 2002; 17: M284
238. Garzoni D, Keusch G, Kleinoeder T, Martin H, Dhondt A, Cremaschi L, Tatsis E, Ibrahim N, Boer W, Kuehne S, Claus M, Zahn M, Schuemann E, Engelmann J, Hickstein H, Wojke R, Gauly A, Passlick-Deetjen J: Reduced complications during hemodialysis by automatic blood volume controlled ultrafiltration. *Int J Artif Organs* 2007;30:16-24.
239. Kraemer, M. New Strategies for reducing Intradialytic Symptoms;1999; *Seminars in Dialysis*, Volume 12, Issue 5 (p 389-395)
240. Barth C, Boer W, Garzoni D, Kuenzi T, Ries W, Schaefer R, Schneditz D, Tsobanelis T, van der SF, Wojke R, Schilling H, Passlick-Deetjen J: Characteristics of hypotension-prone

- haemodialysis patients: is there a critical relative blood volume? *Nephrol Dial Transplant* 2003;18:1353-1360.
241. Dasselaar JJ, Lub-de Hooge MN, Pruijm J, Nijhuis H, Wiersum A, DE Jong PE, Huisman RM, Franssen CF: Relative blood volume changes underestimate total blood volume changes during hemodialysis. *Clin J Am Soc Nephrol* 2007;2:669-674.
 242. THE SUSPENSION STABILITY OF THE BLOOD Fåhræus,R. *Physiological Reviews* 1929; 9: 241-274
 243. Fleming SJ, Wilkinson JS, Greenwood RN, Aldridge C, Baker LR, Cattell WR: Effect of dialysate composition on intercompartmental fluid shift. *Kidney Int* 1987;32:267-273.
 244. Fleming SJ, Wilkinson JS, Aldridge C, Greenwood RN, Muggleston SD, Baker LR, Cattell WR: Dialysis-induced change in erythrocyte volume: effect on change in blood volume calculated from packed cell volume. *Clin Nephrol* 1988;29:63-68.
 245. Maggiore Q, Pizzarelli F, Sisca S, Zoccali C, Parlongo S, Nicolo F, Creazzo G: Blood temperature and vascular stability during hemodialysis and hemofiltration. *Trans Am Soc Artif Intern Organs* 1982;28:523-527.
 246. Pizzarelli F, Sisca S, Zoccali C, Parlongo S, Nicolo F, Creazzo G, Delfino D, Maggiore Q: Blood temperature and cardiovascular stability in hemofiltration. *Int J Artif Organs* 1983;6:37-41.
 247. Maggiore Q, Pizzarelli F, Dattolo P, Maggiore U, Cerrai T: Cardiovascular stability during haemodialysis, haemofiltration and haemodiafiltration. *Nephrol Dial Transplant* 2000;15 Suppl 1:68-73.
 248. Pizzarelli F, Dattolo P, Piacenti M, Morales MA, Cerrai T, Maggiore Q: Non-invasive monitoring of hemodynamic parameters during hemodialysis. *Int J Artif Organs* 1995;18:499-503.
 249. Marcen R, Quereda C, Lamas S, Orofino L, Teruel JL, Ortuno J: Hypoxemia and dialysate temperature. *Nephron* 1987;45:74-75.
 250. Lindholm T, Thysell H, Yamamoto Y, Forsberg B, Gullberg CA: Temperature and vascular stability in hemodialysis. *Nephron* 1985;39:130-133.
 251. Sherman RA, Faustino EF, Bernholc AS, Eisinger RP: Effect of variations in dialysate temperature on blood pressure during hemodialysis. *Am J Kidney Dis* 1984;4:66-68.
 252. Jost CM, Agarwal R, Khair-el-Din T, Grayburn PA, Victor RG, Henrich WL: Effects of cooler temperature dialysate on hemodynamic stability in "problem" dialysis patients. *Kidney Int* 1993;44:606-612.
 253. Levy FL, Grayburn PA, Foulks CJ, Brickner ME, Henrich WL: Improved left ventricular contractility with cool temperature hemodialysis. *Kidney Int* 1992;41:961-965.
 254. Maggiore Q, Dattolo P, Piacenti M, Morales MA, Pelosi G, Pizzarelli F, Cerrai T: Thermal balance and dialysis hypotension. *Int J Artif Organs* 1995;18:518-525.

255. Fine A, Penner B: The protective effect of cool dialysate is dependent on patients' predialysis temperature. *Am J Kidney Dis* 1996;28:262-265.
256. Pizzarelli F: [From dialysate temperature to thermal balance]. *G Ital Nefrol* 2006;23:29-36.
257. Gotch FA, Keen ML, Yarian SR: An analysis of thermal regulation in hemodialysis with one and three compartment models. *ASAIO Trans* 1989;35:622-624.
258. Movilli E, Camerini C, Zein H, D'Avolio G, Sandrini M, Strada A, Maiorca R: A prospective comparison of bicarbonate dialysis, hemodiafiltration, and acetate-free biofiltration in the elderly. *Am J Kidney Dis* 1996;27:541-547.
259. Locatelli F, Mastrangelo F, Redaelli B, Ronco C, Marcelli D, La GG, Orlandini G: Effects of different membranes and dialysis technologies on patient treatment tolerance and nutritional parameters. The Italian Cooperative Dialysis Study Group. *Kidney Int* 1996;50:1293-1302.
260. Karamperis N, Sloth E, Jensen JD: Predilution hemodiafiltration displays no hemodynamic advantage over low-flux hemodialysis under matched conditions. *Kidney Int* 2005;67:1601-1608.
261. Donauer J, Kolblin D, Bek M, Krause A, Bohler J: Ultrafiltration profiling and measurement of relative blood volume as strategies to reduce hemodialysis-related side effects. *Am J Kidney Dis* 2000;36:115-123.
262. van Kuijk WH, Hillion D, Savoie C, Leunissen KM: Critical role of the extracorporeal blood temperature in the hemodynamic response during hemofiltration. *J Am Soc Nephrol* 1997;8:949-955.
263. van der Sande FM, Kooman JP, Konings CJ, Leunissen KM: Thermal effects and blood pressure response during postdilution hemodiafiltration and hemodialysis: the effect of amount of replacement fluid and dialysate temperature. *J Am Soc Nephrol* 2001;12:1916-1920.
264. Maggiore Q, Pizzarelli F, Zoccali C, Sica S, Nicolo F, Parlongo S: Effect of extracorporeal blood cooling on dialytic arterial hypotension. *Proc Eur Dial Transplant Assoc* 1981;18:597-602.
265. Polaschegg HD, inventors. Fresenius AG, assignee. Verfahren und Vorrichtung zum Entziehen von Wārme aus Blut im extrakorporalen Kreislauf. DE patent 3636995. 06/29/1989
266. Provenzano R, Sawaya B, Frinak S, Polaschegg HD, Roy T, Zasuwa G, Dumler F, Levin NW: The effect of cooled dialysate on thermal energy balance in hemodialysis patients. *ASAIO Trans* 1988;34:515-518.
267. Optimization of a Sensor Head for Blood Temperature Measurement during Hemodialysis
Kraemer, M. Steil, H. Polaschegg, H. FRESENIUS AG
Proceedings of the Annual International Conference of the IEEE 29 Oct-1992-Nov 1992
Volume: 4, pp: 1610-1611

268. Schneditz D, Martin K, Kramer M, Kenner T, Skrabal F: Effect of controlled extracorporeal blood cooling on ultrafiltration-induced blood volume changes during hemodialysis. *J Am Soc Nephrol* 1997;8:956-964.
269. van der Sande FM, Kooman JP, Burema JH, Hameleers P, Kerkhofs AM, Barendregt JM, Leunissen KM: Effect of dialysate temperature on energy balance during hemodialysis: quantification of extracorporeal energy transfer. *Am J Kidney Dis* 1999;33:1115-1121.
270. Rosales LM, Schneditz D, Morris AT, Rahmati S, Levin NW: Isothermic hemodialysis and ultrafiltration. *Am J Kidney Dis* 2000;36:353-361.
271. Maggiore Q, Pizzarelli F, Santoro A, Panzetta G, Bonforte G, Hannedouche T, varez de Lara MA, Tsouras I, Loureiro A, Ponce P, Sulkova S, Van RG, Brink H, Kwan JT: The effects of control of thermal balance on vascular stability in hemodialysis patients: results of the European randomized clinical trial. *Am J Kidney Dis* 2002;40:280-290.
272. Selby NM, McIntyre CW: A systematic review of the clinical effects of reducing dialysate fluid temperature. *Nephrol Dial Transplant* 2006;21:1883-1898.
273. DOQI. Clinical Practice Guidelines. Hemodialysis Adequacy.
Am J Kidney Dis 1997; 30 [Suppl 2]: S50–S51
274. Pizzarelli F: From cold dialysis to isothermic dialysis: a twenty-five year voyage. *Nephrol Dial Transplant* 2007;22:1007-1012.
275. van der Sande FM, Wystrychowski G, Kooman JP, Rosales L, Raimann J, Kotanko P, Carter M, Chan CT, Leunissen KM, Levin NW: Control of core temperature and blood pressure stability during hemodialysis. *Clin J Am Soc Nephrol* 2009;4:93-98.
276. van der Sande FM, Rosales LM, Brener Z, Kooman JP, Kuhlmann M, Handelman G, Greenwood RN, Carter M, Schneditz D, Leunissen KM, Levin NW: Effect of ultrafiltration on thermal variables, skin temperature, skin blood flow, and energy expenditure during ultrapure hemodialysis. *J Am Soc Nephrol* 2005;16:1824-1831.
277. Hendrikus W, van KM, Leunissen KM: Hemodynamic stability during different forms of dialysis therapy: a pathogenetic analysis. *Blood Purif* 1996;14:405-420.
278. Stiller S, Bonnie-Schorn E, Grassmann A, Uhlenbusch-Korwer I, Mann H: A critical review of sodium profiling for hemodialysis. *Semin Dial* 2001;14:337-347.
279. Song JH, Park GH, Lee SY, Lee SW, Lee SW, Kim MJ: Effect of sodium balance and the combination of ultrafiltration profile during sodium profiling hemodialysis on the maintenance of the quality of dialysis and sodium and fluid balances. *J Am Soc Nephrol* 2005;16:237-246.
280. Zhou YL, Liu HL, Duan XF, Yao Y, Sun Y, Liu Q: Impact of sodium and ultrafiltration profiling on haemodialysis-related hypotension. *Nephrol Dial Transplant* 2006;21:3231-3237.
281. Dispersion and Absorption in Dielectrics, I. Alternating current characteristics
Cole, K.S. and Cole, R.H.; *Journal of Chemical Physics*, Vol 9: April 1941, pp341-351

282. Thomasset AL, Lenoir J, Roullet C, Jenin P, Beruard M, Bernard C, Baur F: The physiological surveillance of hemodialysis sessions by the continuous measurement of L.F. impedance of the circulating blood (Thomasset's method). *Clin Exp Dial Apheresis* 1983;7:235-250.
283. Nyboer J: Electrical impedance plethysmography; a physical and physiologic approach to peripheral vascular study. *Circulation* 1950;2:811-821.
284. Nyboer J, Sedensky JA: Bioelectrical impedance during renal dialysis. *Proc Clin Dial Transplant Forum* 1974;214-219.
285. Hoffer EC, Meador CK, Simpson DC: Correlation of whole-body impedance with total body water volume. *J Appl Physiol* 1969;27:531-534.
286. Geddes LA, Baker LE: The specific resistance of biological material--a compendium of data for the biomedical engineer and physiologist. *Med Biol Eng* 1967;5:271-293.
287. Epstein BR, Foster KR: Anisotropy in the dielectric properties of skeletal muscle. *Med Biol Eng Comput* 1983;21:51-55.
288. Electric phase angle of cell membranes
K.S.Cole, *Journal of General Physiology*, April 4, 1932
289. Smye SW, Sutcliffe J, Pitt E: A comparison of four commercial systems used to measure whole-body electrical impedance. *Physiol Meas* 1993;14:473-478.
290. Dumler F: Use of bioelectric impedance analysis and dual-energy X-ray absorptiometry for monitoring the nutritional status of dialysis patients. *ASAIO J* 1997;43:256-260.
291. Brozek J: Body composition: models and estimation equations. *Am J Phys Anthropol* 1966;24:239-246.
292. Lukaski HC: Methods for the assessment of human body composition: traditional and new. *Am J Clin Nutr* 1987;46:537-556.
293. Heymsfield SB, Lichtman S, Baumgartner RN, Wang J, Kamen Y, Aliprantis A, Pierson RN, Jr.: Body composition of humans: comparison of two improved four-compartment models that differ in expense, technical complexity, and radiation exposure. *Am J Clin Nutr* 1990;52:52-58.
294. Heymsfield SB, Waki M, Kehayias J, Lichtman S, Dilmanian FA, Kamen Y, Wang J, Pierson RN, Jr.: Chemical and elemental analysis of humans in vivo using improved body composition models. *Am J Physiol* 1991;261:E190-E198.
295. Lohman TG, Going SB: Multicomponent models in body composition research: opportunities and pitfalls. *Basic Life Sci* 1993;60:53-58.
296. Deurenberg P, Andreoli A, De LA: Multi-frequency bioelectrical impedance: a comparison between the Cole-Cole modelling and Hanai equations with the classical impedance index approach. *Ann Hum Biol* 1996;23:31-40.

297. Deurenberg P, Schouten FJ: Loss of total body water and extracellular water assessed by multifrequency impedance. *Eur J Clin Nutr* 1992;46:247-255.
298. Lukaski HC, Johnson PE, Bolonchuk WW, Lykken GI: Assessment of fat-free mass using bioelectrical impedance measurements of the human body. *Am J Clin Nutr* 1985;41:810-817.
299. Meijer JH, De Vries PM, Goovaerts HG, Oe PL, Donker AJ, Schneider H: Measurement of transcellular fluid shift during haemodialysis. Part 1. Method. *Med Biol Eng Comput* 1989;27:147-151.
300. De LA, Deurenberg P, Andreoli A, Sasso GF, Palestini M, Docimo R: Multifrequency impedance in the assessment of body water losses during dialysis. *Ren Physiol Biochem* 1994;17:326-332.
301. Gudivaka R, Schoeller DA, Kushner RF, Bolt MJ: Single- and multifrequency models for bioelectrical impedance analysis of body water compartments. *J Appl Physiol* 1999;87:1087-1096.
302. Piccoli A, Nigrelli S, Caberlotto A, Bottazzo S, Rossi B, Pillon L, Maggiore Q: Bivariate normal values of the bioelectrical impedance vector in adult and elderly populations. *Am J Clin Nutr* 1995;61:269-270.
303. Piccoli A, Pillon L, Dumler F: Impedance vector distribution by sex, race, body mass index, and age in the United States: standard reference intervals as bivariate Z scores. *Nutrition* 2002;18:153-167.
304. FRICKE H: Relation of the permittivity of biological cell suspensions to fractional cell volume. *Nature* 1953;172:731-732.
305. Gabriel S, Lau RW, Gabriel C: The dielectric properties of biological tissues: III. Parametric models for the dielectric spectrum of tissues. *Phys Med Biol* 1996;41:2271-2293.
306. Gabriel S, Lau RW, Gabriel C: The dielectric properties of biological tissues: II. Measurements in the frequency range 10 Hz to 20 GHz. *Phys Med Biol* 1996;41:2251-2269.
307. Gabriel C, Gabriel S, Corthout E: The dielectric properties of biological tissues: I. Literature survey. *Phys Med Biol* 1996;41:2231-2249.
308. Electric phase angle of cell membranes
K.S.Cole, *Journal of General Physiology*, April 4, 1932
309. Schoeller DA: Bioelectrical impedance analysis. What does it measure? *Ann N Y Acad Sci* 2000;904:159-162.
310. Ward L, Cornish BH, Paton NI, Thomas BJ: Multiple frequency bioelectrical impedance analysis: a cross-validation study of the inductor circuit and Cole models. *Physiol Meas* 1999;20:333-347.
311. Cornish BH, Ward LC, Thomas BJ, Jebb SA, Elia M: Evaluation of multiple frequency bioelectrical impedance and Cole-Cole analysis for the assessment of body water volumes in healthy humans. *Eur J Clin Nutr* 1996;50:159-164.

312. Dielectric Theory on the Interfacial Polarization for Two-Phase Mixtures
Hanai,T. Institute for Chemical Research, Kyoto University, Vol 39, No:6 pp341-367, 25 March 1962
313. Kanai H, Sakamoto K, Haeno M: Electrical measurement of fluid distribution in human legs: estimation of extra- and intra-cellular fluid volume. *J Microw Power* 1983;18:233-243.
314. De Vries PM, Meijer JH, Oe LP, van BH, Schneider H, Donker AJ: Conductivity measurements for analysis of transcellular fluid shifts during hemodialysis. *ASAIO Trans* 1987;33:554-556.
315. De Vries PM, Kouw PM, Meijer JH, Oe LP, Schneider H, Donker AJ: Changes in blood parameters during hemodialysis as determined by conductivity measurements. *ASAIO Trans* 1988;34:623-626.
316. De Vries PM, Meijer JH, Vlaanderen K, Visser V, Oe PL, Donker AJ, Schneider H: Measurement of transcellular fluid shift during haemodialysis. Part 2. In vitro and clinical evaluation. *Med Biol Eng Comput* 1989;27:152-158.
317. Scanferla F, Landini S, Fracasso A, Morachiello P, Righetto F, Toffoletto PP, Bazzato G: On-line bioelectric impedance during haemodialysis: monitoring of body fluids and cell membrane status. *Nephrol Dial Transplant* 1990;5 Suppl 1:167-170.
318. Jaffrin MY, Maasrani M, Boudailliez B, Le GA: Extracellular and intracellular fluid volume monitoring during dialysis by multifrequency impedancemetry. *ASAIO J* 1996;42:M533-M538.
319. Maasrani M, Jaffrin MY, Boudailliez B: Continuous measurements by impedance of haematocrit and plasma volume variations during dialysis. *Med Biol Eng Comput* 1997;35:167-171.
320. Jaffrin MY, Maasrani M, Le GA, Boudailliez B: Extra- and intracellular volume monitoring by impedance during haemodialysis using Cole-Cole extrapolation. *Med Biol Eng Comput* 1997;35:266-270.
321. Sinning WE, De Oreo PB, Morgan AL, Brister EC: Monitoring hemodialysis changes with bioimpedance. What do we really measure? *ASAIO J* 1993;39:M584-M589.
322. Ho LT, Kushner RF, Schoeller DA, Gudivaka R, Spiegel DM: Bioimpedance analysis of total body water in hemodialysis patients. *Kidney Int* 1994;46:1438-1442.
323. NIH Consensus Statement (1996) Bioelectrical impedance analysis in body composition measurement. National Institutes of Health Technology Assessment Conference Statement. December 12–14, 1994. *Nutrition*. 12: 749–762.
324. Matthie JR: Second generation mixture theory equation for estimating intracellular water using bioimpedance spectroscopy. *J Appl Physiol* 2005;99:780-781.
325. Matthie JR, Withers PO: The ambiguities of predicting total body water and body cell mass with a single frequency (50KHz) measurement of bioimpedance. *J Am Soc Nephrol* 1995;6:1682-1685.

326. Matthie JR, Withers PO: Bioimpedance, the Cole model equation and the prediction of intra and extracellular water: science or marketing. *Clin Nutr* 1996;15:147-148.
327. De LA, Andreoli A, Matthie J, Withers P: Predicting body cell mass with bioimpedance by using theoretical methods: a technological review. *J Appl Physiol* 1997;82:1542-1558.
328. Segal KR, Van LM, Fitzgerald PI, Hodgdon JA, Van Itallie TB: Lean body mass estimation by bioelectrical impedance analysis: a four-site cross-validation study. *Am J Clin Nutr* 1988;47:7-14.
329. Organ LW, Bradham GB, Gore DT, Lozier SL: Segmental bioelectrical impedance analysis: theory and application of a new technique. *J Appl Physiol* 1994;77:98-112.
330. Baumgartner RN, Chumlea WC, Roche AF: Estimation of body composition from bioelectric impedance of body segments. *Am J Clin Nutr* 1989;50:221-226.
331. Fuller NJ, Elia M: Potential use of bioelectrical impedance of the 'whole body' and of body segments for the assessment of body composition: comparison with densitometry and anthropometry. *Eur J Clin Nutr* 1989;43:779-791.
332. Zhu F, Schneditz D, Wang E, Martin K, Morris AT, Levin NW: Validation of changes in extracellular volume measured during hemodialysis using a segmental bioimpedance technique. *ASAIO J* 1998;44:M541-M545.
333. Zhu F, Schneditz D, Wang E, Levin NW: Dynamics of segmental extracellular volumes during changes in body position by bioimpedance analysis. *J Appl Physiol* 1998;85:497-504.
334. Zhu F, Schneditz D, Levin NW: Sum of segmental bioimpedance analysis during ultrafiltration and hemodialysis reduces sensitivity to changes in body position. *Kidney Int* 1999;56:692-699.
335. Zhu F, Kuhlmann MK, Kaysen GA, Sarkar S, Kaitwatcharachai C, Khilnani R, Stevens L, Leonard EF, Wang J, Heymsfield S, Levin NW: Segment-specific resistivity improves body fluid volume estimates from bioimpedance spectroscopy in hemodialysis patients. *J Appl Physiol* 2006;100:717-724.
336. Carter M, Zhu F, Kotanko P, Kuhlmann M, Ramirez L, Heymsfield SB, Handelman G, Levin NW: Assessment of body composition in dialysis patients by arm bioimpedance compared to MRI and 40K measurements. *Blood Purif* 2009;27:330-337.
337. Zhu F, Wystrychowski G, Kitzler T, Thijssen S, Kotanko P, Levin NW: Application of bioimpedance techniques to peritoneal dialysis. *Contrib Nephrol* 2006;150:119-128.
338. Song JH, Lee SW, Kim GA, Kim MJ: Measurement of fluid shift in CAPD patients using segmental bioelectrical impedance analysis. *Perit Dial Int* 1999;19:386-390.
339. Cornish BH, Jacobs A, Thomas BJ, Ward LC: Optimizing electrode sites for segmental bioimpedance measurements. *Physiol Meas* 1999;20:241-250.
340. Rosell J, Murphy D, Pallas R, Rolfe P: Analysis and assessment of errors in a parallel data acquisition system for electrical impedance tomography. *Clin Phys Physiol Meas* 1988;9 Suppl A:93-99.

341. Zhu F, Schneditz D, Kaufman AM, Levin NW: Estimation of body fluid changes during peritoneal dialysis by segmental bioimpedance analysis. *Kidney Int* 2000;57:299-306.
342. Chanchairujira T, Mehta RL: Assessing fluid change in hemodialysis: whole body versus sum of segmental bioimpedance spectroscopy. *Kidney Int* 2001;60:2337-2342.
343. Carter M, Morris AT, Zhu F, Zaluska W, Levin NW: Effect of body mass index (BMI) on estimation of extracellular volume (ECV) in hemodialysis (HD) patients using segmental and whole body bioimpedance analysis. *Physiol Meas* 2005;26:S93-S99.
344. Zaluska W, Malecka T, Mozul S, Ksiazek A: [Whole body versus segmental bioimpedance measurements (BIS) of electrical resistance (Re) and extracellular volume (ECV) for assessment of dry weight in end-stage renal patients treated by hemodialysis]. *Przegl Lek* 2004;61:70-73.
345. Kyle UG, Bosaeus I, De Lorenzo AD, Deurenberg P, Elia M, Manuel GJ, Lilienthal HB, Kent-Smith L, Melchior JC, Pirlich M, Scharfetter H, Schols WJ, Pichard C: Bioelectrical impedance analysis-part II: utilization in clinical practice. *Clin Nutr* 2004;23:1430-1453.
346. Kyle UG, Bosaeus I, De Lorenzo AD, Deurenberg P, Elia M, Gomez JM, Heitmann BL, Kent-Smith L, Melchior JC, Pirlich M, Scharfetter H, Schols AM, Pichard C: Bioelectrical impedance analysis--part I: review of principles and methods. *Clin Nutr* 2004;23:1226-1243.
347. Sun SS, Chumlea WC, Heymsfield SB, Lukaski HC, Schoeller D, Friedl K, Kuczmarski RJ, Flegal KM, Johnson CL, Hubbard VS: Development of bioelectrical impedance analysis prediction equations for body composition with the use of a multicomponent model for use in epidemiologic surveys. *Am J Clin Nutr* 2003;77:331-340.
348. Kotler DP, Burastero S, Wang J, Pierson RN, Jr.: Prediction of body cell mass, fat-free mass, and total body water with bioelectrical impedance analysis: effects of race, sex, and disease. *Am J Clin Nutr* 1996;64:489S-497S.
349. Chertow GM, Lazarus JM, Lew NL, Ma L, Lowrie EG: Bioimpedance norms for the hemodialysis population. *Kidney Int* 1997;52:1617-1621.
350. Maggiore Q, Nigrelli S, Ciccarelli C, Grimaldi C, Rossi GA, Michelassi C: Nutritional and prognostic correlates of bioimpedance indexes in hemodialysis patients. *Kidney Int* 1996;50:2103-2108.
351. Ho LT, Kushner RF, Schoeller DA, Gudivaka R, Spiegel DM: Bioimpedance analysis of total body water in hemodialysis patients. *Kidney Int* 1994;46:1438-1442.
352. Scharfetter H, Wirnsberger GH, Holzer H, Hutten H: Influence of ionic shifts during dialysis on volume estimations with multifrequency impedance analysis. *Med Biol Eng Comput* 1997;35:96-102.
353. Piccoli A: Bioelectric impedance vector distribution in peritoneal dialysis patients with different hydration status. *Kidney Int* 2004;65:1050-1063.
354. Piccoli A, Rossi B, Pillon L, Bucciante G: Body fluid overload and bioelectrical impedance analysis in renal patients. *Miner Electrolyte Metab* 1996;22:76-78.

355. Jaffrin MY, Fenech M, Moreno MV, Kieffer R: Total body water measurement by a modification of the bioimpedance spectroscopy method. *Med Biol Eng Comput* 2006;44:873-882.
356. Morel H, Jaffrin MY: A bridge from bioimpedance spectroscopy to 50 kHz bioimpedance analysis: application to total body water measurements. *Physiol Meas* 2008;29:S465-S478.
357. Kushner RF, Schoeller DA, Fjeld CR, Danford L: Is the impedance index (ht^2/R) significant in predicting total body water? *Am J Clin Nutr* 1992;56:835-839.
358. Hannan WJ, Cowen SJ, Fearon KC, Plester CE, Falconer JS, Richardson RA: Evaluation of multi-frequency bio-impedance analysis for the assessment of extracellular and total body water in surgical patients. *Clin Sci (Lond)* 1994;86:479-485.
359. Deurenberg P, Tagliabue A, Schouten FJ: Multi-frequency impedance for the prediction of extracellular water and total body water. *Br J Nutr* 1995;73:349-358.
360. Chamney PW, Kramer M, Rode C, Kleinekofort W, Wizemann V: A new technique for establishing dry weight in hemodialysis patients via whole body bioimpedance. *Kidney Int* 2002;61:2250-2258.
361. Piccoli A: Identification of operational clues to dry weight prescription in hemodialysis using bioimpedance vector analysis. The Italian Hemodialysis-Bioelectrical Impedance Analysis (HD-BIA) Study Group. *Kidney Int* 1998;53:1036-1043.
362. Pillon L, Piccoli A, Lowrie EG, Lazarus JM, Chertow GM: Vector length as a proxy for the adequacy of ultrafiltration in hemodialysis. *Kidney Int* 2004;66:1266-1271.
363. Zhu F, Sarkar S, Kaitwatcharachai C, Greenwood R, Ronco C, Levin NW: Methods and reproducibility of measurement of resistivity in the calf using regional bioimpedance analysis. *Blood Purif* 2003;21:131-136.
364. Zhu F, Kuhlmann MK, Kotanko P, Seibert E, Leonard EF, Levin NW: A method for the estimation of hydration state during hemodialysis using a calf bioimpedance technique. *Physiol Meas* 2008;29:S503-S516.
365. de Bold AJ, Borenstein HB, Veress AT, Sonnenberg H: A rapid and potent natriuretic response to intravenous injection of atrial myocardial extract in rats. *Life Sci* 1981;28:89-94.
366. Kangawa K, Fukuda A, Kubota I, Hayashi Y, Minamitake Y, Matsuo H: Human atrial natriuretic polypeptides (hANP): purification, structure synthesis and biological activity. *J Hypertens Suppl* 1984;2:S321-S323.
367. Sudoh T, Minamino N, Kangawa K, Matsuo H: C-type natriuretic peptide (CNP): a new member of natriuretic peptide family identified in porcine brain. *Biochem Biophys Res Commun* 1990;168:863-870.
368. Sudoh T, Maekawa K, Kojima M, Minamino N, Kangawa K, Matsuo H: Cloning and sequence analysis of cDNA encoding a precursor for human brain natriuretic peptide. *Biochem Biophys Res Commun* 1989;159:1427-1434.

369. Sudoh T, Kangawa K, Minamino N, Matsuo H: A new natriuretic peptide in porcine brain. *Nature* 1988;332:78-81.
370. Ueda S, Sudoh T, Fukuda K, Kangawa K, Minamino N, Matsuo H: Identification of alpha atrial natriuretic peptide [4-28] and [5-28] in porcine brain. *Biochem Biophys Res Commun* 1987;149:1055-1062.
371. Schirger JA, Heublein DM, Chen HH, Lisy O, Jougasaki M, Wennberg PW, Burnett JC, Jr.: Presence of Dendroaspis natriuretic peptide-like immunoreactivity in human plasma and its increase during human heart failure. *Mayo Clin Proc* 1999;74:126-130.
372. Schweitz H, Vigne P, Moinier D, Frelin C, Lazdunski M: A new member of the natriuretic peptide family is present in the venom of the green mamba (*Dendroaspis angusticeps*). *J Biol Chem* 1992;267:13928-13932.
373. Kitamura K, Ichiki Y, Tanaka M, Kawamoto M, Emura J, Sakakibara S, Kangawa K, Matsuo H, Eto T: Immunoreactive adrenomedullin in human plasma. *FEBS Lett* 1994;341:288-290.
374. Kitamura K, Sakata J, Kangawa K, Kojima M, Matsuo H, Eto T: Cloning and characterization of cDNA encoding a precursor for human adrenomedullin. *Biochem Biophys Res Commun* 1993;194:720-725.
375. Kitamura K, Kangawa K, Kawamoto M, Ichiki Y, Nakamura S, Matsuo H, Eto T: Adrenomedullin: a novel hypotensive peptide isolated from human pheochromocytoma. *Biochem Biophys Res Commun* 1993;192:553-560.
376. Kangawa K, Kitamura K, Minamino N, Eto T, Matsuo H: Adrenomedullin: a new hypotensive peptide. *J Hypertens Suppl* 1996;14:S105-S110.
377. Kangawa K, Kitamura K, Minamino N, Matsuo H: Adrenomedullin: a new modulator of vascular tone. *J Card Fail* 1996;2:S135-S140.
378. Mallamaci F, Zoccali C, Parlongo S, Cutrupi S, Tripepi G, Postorino M: Plasma adrenomedullin during acute changes in intravascular volume in hemodialysis patients. *Kidney Int* 1998;54:1697-1703.
379. Nishikimi T, Saito Y, Kitamura K, Ishimitsu T, Eto T, Kangawa K, Matsuo H, Omae T, Matsuoka H: Increased plasma levels of adrenomedullin in patients with heart failure. *J Am Coll Cardiol* 1995;26:1424-1431.
380. Wharton J, Gulbenkian S, Merighi A, Kuhn DM, Jahn R, Taylor KM, Polak JM: Immunohistochemical and ultrastructural localisation of peptide-containing nerves and myocardial cells in the human atrial appendage. *Cell Tissue Res* 1988;254:155-166.
381. Lee YS, Lee CP: Secretory granules containing atrial natriuretic polypeptide in human ventricular cardiomyocytes. An electron microscopic immunocytochemical study. *Jpn Heart J* 1990;31:661-670.
382. Nag AC, Schultz DE, Lee ML: Expression of atrial natriuretic peptide in cultured adult cardiac ventricular muscle cells as studied by immunofluorescence microscopy. *Cell Mol Biol (Noisy - le-grand)* 1995;41:813-825.

383. Tateyama H, Hino J, Minamino N, Kangawa K, Ogihara T, Matsuo H: Characterization of immunoreactive brain natriuretic peptide in human cardiac atrium. *Biochem Biophys Res Commun* 1990;166:1080-1087.
384. Hino J, Tateyama H, Minamino N, Kangawa K, Matsuo H: Isolation and identification of human brain natriuretic peptides in cardiac atrium. *Biochem Biophys Res Commun* 1990;167:693-700.
385. Hasegawa K, Fujiwara H, Doyama K, Miyamae M, Fujiwara T, Suga S, Mukoyama M, Nakao K, Imura H, Sasayama S: Ventricular expression of brain natriuretic peptide in hypertrophic cardiomyopathy. *Circulation* 1993;88:372-380.
386. Mukoyama M, Nakao K, Hosoda K, Suga S, Saito Y, Ogawa Y, Shirakami G, Jougasaki M, Obata K, Yasue H, .: Brain natriuretic peptide as a novel cardiac hormone in humans. Evidence for an exquisite dual natriuretic peptide system, atrial natriuretic peptide and brain natriuretic peptide. *J Clin Invest* 1991;87:1402-1412.
387. Nakamura S, Naruse M, Naruse K, Kawana M, Nishikawa T, Hosoda S, Tanaka I, Yoshimi T, Yoshihara I, Inagami T, .: Atrial natriuretic peptide and brain natriuretic peptide coexist in the secretory granules of human cardiac myocytes. *Am J Hypertens* 1991;4:909-912.
388. Chen HH, Burnett JC, Jr.: C-type natriuretic peptide: the endothelial component of the natriuretic peptide system. *J Cardiovasc Pharmacol* 1998;32 Suppl 3:S22-S28.
389. Furuya M, Miyazaki T, Honbou N, Kawashima K, Ohno T, Tanaka S, Kangawa K, Matsuo H: C-type natriuretic peptide inhibits intimal thickening after vascular injury. *Ann N Y Acad Sci* 1995;748:517-523.
390. Furuya M, Aisaka K, Miyazaki T, Honbou N, Kawashima K, Ohno T, Tanaka S, Minamino N, Kangawa K, Matsuo H: C-type natriuretic peptide inhibits intimal thickening after vascular injury. *Biochem Biophys Res Commun* 1993;193:248-253.
391. Kalra PR, Anker SD, Struthers AD, Coats AJ: The role of C-type natriuretic peptide in cardiovascular medicine. *Eur Heart J* 2001;22:997-1007.
392. Tao H, Zhang LM, Castresana MR, Shillcutt SD, Newman WH: C-natriuretic peptide but not atrial natriuretic peptide increases cyclic GMP in cerebral arterial smooth muscle cells. *Life Sci* 1995;56:2357-2365.
393. Richards AM, Lainchbury JG, Nicholls MG, Cameron AV, Yandle TG: Dendroaspis natriuretic peptide: endogenous or dubious? *Lancet* 2002;359:5-6.
394. Schirger JA, Heublein DM, Chen HH, Lisy O, Jougasaki M, Wennberg PW, Burnett JC, Jr.: Presence of Dendroaspis natriuretic peptide-like immunoreactivity in human plasma and its increase during human heart failure. *Mayo Clin Proc* 1999;74:126-130.
395. Woodard GE, Rosado JA, Brown J: Dendroaspis natriuretic peptide-like immunoreactivity and its regulation in rat aortic vascular smooth muscle. *Peptides* 2002;23:23-29.
396. Lisy O, Jougasaki M, Heublein DM, Schirger JA, Chen HH, Wennberg PW, Burnett JC: Renal actions of synthetic dendroaspis natriuretic peptide. *Kidney Int* 1999;56:502-508.

397. Kalra PR, Clague JR, Bolger AP, Anker SD, Poole-Wilson PA, Struthers AD, Coats AJ: Myocardial production of C-type natriuretic peptide in chronic heart failure. *Circulation* 2003;107:571-573.
398. Kalra PR, Anker SD, Struthers AD, Coats AJ: The role of C-type natriuretic peptide in cardiovascular medicine. *Eur Heart J* 2001;22:997-1007.
399. Best PJ, Burnett JC, Wilson SH, Holmes DR, Jr., Lerman A: Dendroaspis natriuretic peptide relaxes isolated human arteries and veins. *Cardiovasc Res* 2002;55:375-384.
400. Lisy O, Lainchbury JG, Leskinen H, Burnett JC, Jr.: Therapeutic actions of a new synthetic vasoactive and natriuretic peptide, dendroaspis natriuretic peptide, in experimental severe congestive heart failure. *Hypertension* 2001;37:1089-1094.
401. Lisy O, Lainchbury JG, Leskinen H, Burnett JC, Jr.: Therapeutic actions of a new synthetic vasoactive and natriuretic peptide, dendroaspis natriuretic peptide, in experimental severe congestive heart failure. *Hypertension* 2001;37:1089-1094.
402. Schirger JA, Heublein DM, Chen HH, Lisy O, Jougasaki M, Wennberg PW, Burnett JC, Jr.: Presence of Dendroaspis natriuretic peptide-like immunoreactivity in human plasma and its increase during human heart failure. *Mayo Clin Proc* 1999;74:126-130.
403. Ishimitsu T, Nishikimi T, Saito Y, Kitamura K, Eto T, Kangawa K, Matsuo H, Omae T, Matsuoka H: Plasma levels of adrenomedullin, a newly identified hypotensive peptide, in patients with hypertension and renal failure. *J Clin Invest* 1994;94:2158-2161.
404. Kangawa K, Kitamura K, Minamino N, Eto T, Matsuo H: Adrenomedullin: a new hypotensive peptide. *J Hypertens Suppl* 1996;14:S105-S110.
405. Kitamura K, Kangawa K, Ishiyama Y, Washimine H, Ichiki Y, Kawamoto M, Minamino N, Matsuo H, Eto T: Identification and hypotensive activity of proadrenomedullin N-terminal 20 peptide (PAMP). *FEBS Lett* 1994;351:35-37.
406. Kitamura K, Kangawa K, Kawamoto M, Ichiki Y, Nakamura S, Matsuo H, Eto T: Adrenomedullin: a novel hypotensive peptide isolated from human pheochromocytoma. *Biochem Biophys Res Commun* 1993;192:553-560.
407. Ishihara T, Yokota N, Hisanaga S, Fujimoto S, Hirayama N, Kato J, Kitamura K, Eto T: Increased plasma levels of mature form of adrenomedullin in patients with chronic renal failure. *Clin Nephrol* 1999;52:119-123.
408. Kojima H, Tsujimoto T, Uemura M, Takaya A, Okamoto S, Ueda S, Nishio K, Miyamoto S, Kubo A, Minamino N, Kangawa K, Matsuo H, Fukui H: Significance of increased plasma adrenomedullin concentration in patients with cirrhosis. *J Hepatol* 1998;28:840-846.
409. Nishikimi T, Horio T, Kohmoto Y, Yoshihara F, Nagaya N, Inenaga T, Saito M, Teranishi M, Nakamura M, Ohruji M, Kawano Y, Matsuo H, Ishimitsu T, Takishita S, Matsuoka H, Kangawa K: Molecular forms of plasma and urinary adrenomedullin in normal, essential hypertension and chronic renal failure. *J Hypertens* 2001;19:765-773.

410. Nishikimi T, Matsuoka H, Shimada K, Matsuo H, Kangawa K: Production and clearance sites of two molecular forms of adrenomedullin in human plasma. *Am J Hypertens* 2000;13:1032-1034.
411. Ogawa T, Vatta M, Bruneau BG, de Bold AJ: Characterization of natriuretic peptide production by adult heart atria. *Am J Physiol* 1999;276:H1977-H1986.
412. Nakagawa O, Ogawa Y, Itoh H, Suga S, Komatsu Y, Kishimoto I, Nishino K, Yoshimasa T, Nakao K: Rapid transcriptional activation and early mRNA turnover of brain natriuretic peptide in cardiocyte hypertrophy. Evidence for brain natriuretic peptide as an "emergency" cardiac hormone against ventricular overload. *J Clin Invest* 1995;96:1280-1287.
413. Hama N, Itoh H, Shirakami G, Nakagawa O, Suga S, Ogawa Y, Masuda I, Nakanishi K, Yoshimasa T, Hashimoto Y, .: Rapid ventricular induction of brain natriuretic peptide gene expression in experimental acute myocardial infarction. *Circulation* 1995;92:1558-1564.
414. Caput D, Beutler B, Hartog K, Thayer R, Brown-Shimer S, Cerami A: Identification of a common nucleotide sequence in the 3'-untranslated region of mRNA molecules specifying inflammatory mediators. *Proc Natl Acad Sci U S A* 1986;83:1670-1674.
415. Wypij DM, Harris RB: Characterization of homogeneous atrial granule serine proteinase, a candidate processing enzyme of pro-atrial natriuretic factor. *Life Sci* 1992;50:523-531.
416. Feller SM, Gagelmann M, Forssmann WG: Urodilatin: a newly described member of the ANP family. *Trends Pharmacol Sci* 1989;10:93-94.
417. Forssmann WG: Urodilatin (ularitide, INN): a renal natriuretic peptide. Molecular biology and clinical importance. *Nephron* 1995;69:211-222.
418. Gunning M, Brenner BM: Urodilatin: a potent natriuretic peptide of renal origin. *Curr Opin Nephrol Hypertens* 1993;2:857-862.
419. Gunning M, Brenner BM: Urodilatin: a potent natriuretic peptide of renal origin. *Curr Opin Nephrol Hypertens* 1993;2:857-862.
420. Herten M, Lenz W, Gerzer R, Drummer C: The renal natriuretic peptide urodilatin is present in human kidney. *Nephrol Dial Transplant* 1998;13:2529-2535.
421. Han B, Hasin Y: Cardiovascular effects of natriuretic peptides and their interrelation with endothelin-1. *Cardiovasc Drugs Ther* 2003;17:41-52.
422. Heim JM, Gottmann K, Weil J, Schiffel H, Lauster F, Loeschke K, Gerzer R: Effects of a small bolus dose of ANF in healthy volunteers and in patients with volume retaining disorders. *Klin Wochenschr* 1990;68:709-717.
423. Ishihara T, Aisaka K, Hattori K, Hamasaki S, Morita M, Noguchi T, Kangawa K, Matsuo H: Vasodilatory and diuretic actions of alpha-human atrial natriuretic polypeptide (alpha-hANP). *Life Sci* 1985;36:1205-1215.
424. de Bold AJ: Atrial natriuretic factor: a hormone produced by the heart. *Science* 1985;230:767-770.

425. de Bold AJ, Kuroski-de Bold ML, Boer PH, Dube G, Mangat H, Johnson F: A decade of atrial natriuretic factor research. *Can J Physiol Pharmacol* 1991;69:1480-1485.
426. Lai CP, Egashira K, Tashiro H, Narabayashi H, Koyanagi S, Imaizumi T, Takeshita A: Beneficial effects of atrial natriuretic peptide on exercise-induced myocardial ischemia in patients with stable effort angina pectoris. *Circulation* 1993;87:144-151.
427. Schulz-Knappe P, Forssmann K, Herbst F, Hock D, Pipkorn R, Forssmann WG: Isolation and structural analysis of "urodilatin", a new peptide of the cardiodilatin-(ANP)-family, extracted from human urine. *Klin Wochenschr* 1988;66:752-759.
428. Marin-Grez M, Fleming JT, Steinhausen M: Atrial natriuretic peptide causes pre-glomerular vasodilatation and post-glomerular vasoconstriction in rat kidney. *Nature* 1986;324:473-476.
429. Fried TA, McCoy RN, Osgood RW, Stein JH: Effect of atriopeptin II on determinants of glomerular filtration rate in the in vitro perfused dog glomerulus. *Am J Physiol* 1986;250:F1119-F1122.
430. Ishimitsu T, Hirata Y, Matsuoka H, Ishii M, Sugimoto T, Kangawa K, Matsuo H: In vivo and in vitro effects of atrial natriuretic peptide on renin release. *Clin Exp Pharmacol Physiol* 1992;19:711-716.
431. Kuribayashi T, Nakazato M, Tanaka M, Nagamine M, Kurihara T, Kangawa K, Matsuo H: Renal effects of human alpha-atrial natriuretic polypeptide. *N Engl J Med* 1985;312:1456-1457.
432. Dillingham MA, Anderson RJ: Inhibition of vasopressin action by atrial natriuretic factor. *Science* 1986;231:1572-1573.
433. Zeidel ML: Regulation of collecting duct Na⁺ reabsorption by ANP 31-67. *Clin Exp Pharmacol Physiol* 1995;22:121-124.
434. Blackburn RE, Samson WK, Fulton RJ, Stricker EM, Verbalis JG: Central oxytocin and ANP receptors mediate osmotic inhibition of salt appetite in rats. *Am J Physiol* 1995;269:R245-R251.
435. Burrell LM, Lambert HJ, Baylis PH: The effect of drinking on atrial natriuretic peptide, vasopressin and thirst appreciation in hyperosmolar man. *Clin Endocrinol (Oxf)* 1991;35:229-234.
436. Burrell LM, Lambert HJ, Baylis PH: Effect of atrial natriuretic peptide on thirst and arginine vasopressin release in humans. *Am J Physiol* 1991;260:R475-R479.
437. Furuya M, Miyazaki T, Honbou N, Kawashima K, Ohno T, Tanaka S, Kangawa K, Matsuo H: C-type natriuretic peptide inhibits intimal thickening after vascular injury. *Ann N Y Acad Sci* 1995;748:517-523.
438. Furuya M, Yoshida M, Hayashi Y, Ohnuma N, Minamino N, Kangawa K, Matsuo H: C-type natriuretic peptide is a growth inhibitor of rat vascular smooth muscle cells. *Biochem Biophys Res Commun* 1991;177:927-931.
439. Koller KJ, Goeddel DV: Molecular biology of the natriuretic peptides and their receptors. *Circulation* 1992;86:1081-1088.

440. Kishimoto I, Dubois SK, Garbers DL: The heart communicates with the kidney exclusively through the guanylyl cyclase-A receptor: acute handling of sodium and water in response to volume expansion. *Proc Natl Acad Sci U S A* 1996;93:6215-6219.
441. Misono KS: Natriuretic peptide receptor: structure and signaling. *Mol Cell Biochem* 2002;230:49-60.
442. Tremblay J, Desjardins R, Hum D, Gutkowska J, Hamet P: Biochemistry and physiology of the natriuretic peptide receptor guanylyl cyclases. *Mol Cell Biochem* 2002;230:31-47.
443. Pandey KN: Intracellular trafficking and metabolic turnover of ligand-bound guanylyl cyclase/atrial natriuretic peptide receptor-A into subcellular compartments. *Mol Cell Biochem* 2002;230:61-72.
444. Smith MW, Espiner EA, Yandle TG, Charles CJ, Richards AM: Delayed metabolism of human brain natriuretic peptide reflects resistance to neutral endopeptidase. *J Endocrinol* 2000;167:239-246.
445. Charles CJ, Espiner EA, Nicholls MG, Richards AM, Yandle TG, Protter A, Kosoglou T: Clearance receptors and endopeptidase 24.11: equal role in natriuretic peptide metabolism in conscious sheep. *Am J Physiol* 1996;271:R373-R380.
446. Andreassi MG, Del Ry S, Palmieri C, Clerico A, Biagini A, Giannessi D: Up-regulation of 'clearance' receptors in patients with chronic heart failure: a possible explanation for the resistance to biological effects of cardiac natriuretic hormones. *Eur J Heart Fail* 2001;3:407-414.
447. Charloux A, Piquard F, Doutreleau S, Brandenberger G, Geny B: Mechanisms of renal hyporesponsiveness to ANP in heart failure. *Eur J Clin Invest* 2003;33:769-778.
448. Schirger JA, Grantham JA, Kullo IJ, Jougasaki M, Wennberg PW, Chen HH, Lisy O, Miller V, Simari RD, Burnett JC, Jr.: Vascular actions of brain natriuretic peptide: modulation by atherosclerosis and neutral endopeptidase inhibition. *J Am Coll Cardiol* 2000;35:796-801.
449. Soleilhac JM, Lucas E, Beaumont A, Turcaud S, Michel JB, Ficheux D, Fournie-Zaluski MC, Roques BP: A 94-kDa protein, identified as neutral endopeptidase-24.11, can inactivate atrial natriuretic peptide in the vascular endothelium. *Mol Pharmacol* 1992;41:609-614.
450. Achilihu G, Frishman WH, Landau A: Neutral endopeptidase inhibitors and atrial natriuretic peptide. *J Clin Pharmacol* 1991;31:758-762.
451. Worthley MI, Corti R, Worthley SG: Vasopeptidase inhibitors: will they have a role in clinical practice? *Br J Clin Pharmacol* 2004;57:27-36.
452. Edwards BS, Zimmerman RS, Schwab TR, Heublein DM, Burnett JC, Jr.: Atrial stretch, not pressure, is the principal determinant controlling the acute release of atrial natriuretic factor. *Circ Res* 1988;62:191-195.
453. Kinnunen P, Vuolteenaho O, Ruskoaho H: Mechanisms of atrial and brain natriuretic peptide release from rat ventricular myocardium: effect of stretching. *Endocrinology* 1993;132:1961-1970.

454. Indolfi C, Piscione F, Volpe M, Focaccio A, Lembo G, Trimarco B, Condorelli M, Chiariello M: Cardiac effects of atrial natriuretic peptide in subjects with normal left ventricular function. *Am J Cardiol* 1989;63:353-357.
455. Focaccio A, Volpe M, Ambrosio G, Lembo G, Pannain S, Rubattu S, Enea I, Pignalosa S, Chiariello M: Angiotensin II directly stimulates release of atrial natriuretic factor in isolated rabbit hearts. *Circulation* 1993;87:192-198.
456. Charloux A, Piquard F, Doutreleau S, Brandenberger G, Geny B: Mechanisms of renal hyporesponsiveness to ANP in heart failure. *Eur J Clin Invest* 2003;33:769-778.
457. Andreassi MG, Del Ry S, Palmieri C, Clerico A, Biagini A, Giannessi D: Up-regulation of 'clearance' receptors in patients with chronic heart failure: a possible explanation for the resistance to biological effects of cardiac natriuretic hormones. *Eur J Heart Fail* 2001;3:407-414.
458. Andreassi MG, Del Ry S, Giannessi D: [Natriuretic peptide receptors and heart failure]. *Cardiologia* 1999;44:241-248.
459. Almeida SS, Azevedo A, Castro A, Frioies F, Freitas J, Ferreira A, Bettencourt P: B-type natriuretic peptide is related to left ventricular mass in hypertensive patients but not in athletes. *Cardiology* 2002;98:113-115.
460. Almeida P, Azevedo A, Rodrigues R, Dias P, Frioies F, Vazquez B, Abreu-Lima C, Bettencourt P, Barros H: B-type natriuretic peptide and left ventricular hypertrophy in hypertensive patients. *Rev Port Cardiol* 2003;22:327-336.
461. Kohno M, Horio T, Yokokawa K, Yasunari K, Ikeda M, Minami M, Kurihara N, Takeda T: Brain natriuretic peptide as a marker for hypertensive left ventricular hypertrophy: changes during 1-year antihypertensive therapy with angiotensin-converting enzyme inhibitor. *Am J Med* 1995;98:257-265.
462. Sigurdsson A, Swedberg K: Left ventricular remodelling, neurohormonal activation and early treatment with enalapril (CONSENSUS II) following myocardial infarction. *Eur Heart J* 1994;15 Suppl B:14-19.
463. Bonarjee VV, Omland T, Nilsen DW, Carstensen S, Berning J, Edner M, Caidahl K: Left ventricular volumes, ejection fraction, and plasma proatrial natriuretic factor (1-98) after withdrawal of enalapril treatment initiated early after myocardial infarction. CONSENSUS II Multi-Echo Study Group. *Br Heart J* 1995;73:506-510.
464. Pfeffer MA, Braunwald E, Moye LA, Basta L, Brown EJ, Jr., Cuddy TE, Davis BR, Geltman EM, Goldman S, Flaker GC, .: Effect of captopril on mortality and morbidity in patients with left ventricular dysfunction after myocardial infarction. Results of the survival and ventricular enlargement trial. The SAVE Investigators. *N Engl J Med* 1992;327:669-677.
465. Retterstol L, Djurovic S, Bohn M, Bakken A, Erikssen J, Berg K: Plasma N-terminal pro-atrial natriuretic peptide predicts death after premature myocardial infarction, but not as well as radionuclide ejection fraction. A ten-year follow-up study. *Scand Cardiovasc J* 2001;35:373-378.

466. Pinto FJ: Echocardiography or Nt-proANP in post-myocardial infarction patients: is one enough? *Eur Heart J* 2002;23:996-997.
467. Omland T, Aarsland T, Aakvaag A, Lie RT, Dickstein K: Prognostic value of plasma atrial natriuretic factor, norepinephrine and epinephrine in acute myocardial infarction. *Am J Cardiol* 1993;72:255-259.
468. Omland T, Bonarjee VV, Nilsen DW, Sundsfjord JA, Lie RT, Thibault G, Dickstein K: Prognostic significance of N-terminal pro-atrial natriuretic factor (1-98) in acute myocardial infarction: comparison with atrial natriuretic factor (99-126) and clinical evaluation. *Br Heart J* 1993;70:409-414.
469. Nakamura M, Arakawa N, Yoshida H, Funakoshi T, Chiba M, Makita S, Aoki H, Hiramori K: Prognostic implications of plasma levels of atrial natriuretic factor in patients with acute myocardial infarction. *Intern Med* 1993;32:112-115.
470. Hall C, Ihlen H, Bonarjee V, Dickstein K, Kjekshus J: N-terminal proatrial natriuretic peptide in primary care: relation to echocardiographic indices of cardiac function in mild to moderate cardiac disease. *Int J Cardiol* 2003;89:197-205.
471. Bonarjee VV, Omland T, Nilsen DW, Carstensen S, Berning J, Edner M, Caidahl K: Left ventricular volumes, ejection fraction, and plasma proatrial natriuretic factor (1-98) after withdrawal of enalapril treatment initiated early after myocardial infarction. CONSENSUS II Multi-Echo Study Group. *Br Heart J* 1995;73:506-510.
472. Richards AM, Nicholls MG, Espiner EA, Lainchbury JG, Troughton RW, Elliott J, Frampton C, Turner J, Crozier IG, Yandle TG: B-type natriuretic peptides and ejection fraction for prognosis after myocardial infarction. *Circulation* 2003;107:2786-2792.
473. Omland T, Aakvaag A, Bonarjee VV, Caidahl K, Lie RT, Nilsen DW, Sundsfjord JA, Dickstein K: Plasma brain natriuretic peptide as an indicator of left ventricular systolic function and long-term survival after acute myocardial infarction. Comparison with plasma atrial natriuretic peptide and N-terminal proatrial natriuretic peptide. *Circulation* 1996;93:1963-1969.
474. Nagaya N, Nishikimi T, Goto Y, Miyao Y, Kobayashi Y, Morii I, Daikoku S, Matsumoto T, Miyazaki S, Matsuoka H, Takishita S, Kangawa K, Matsuo H, Nonogi H: Plasma brain natriuretic peptide is a biochemical marker for the prediction of progressive ventricular remodeling after acute myocardial infarction. *Am Heart J* 1998;135:21-28.
475. Morita E, Yasue H, Yoshimura M, Ogawa H, Jougasaki M, Matsumura T, Mukoyama M, Nakao K: Increased plasma levels of brain natriuretic peptide in patients with acute myocardial infarction. *Circulation* 1993;88:82-91.
476. Horio T, Shimada K, Kohno M, Yoshimura T, Kawarabayashi T, Yasunari K, Murakawa K, Yokokawa K, Ikeda M, Fukui T, .: Serial changes in atrial and brain natriuretic peptides in patients with acute myocardial infarction treated with early coronary angioplasty. *Am Heart J* 1993;126:293-299.
477. Hama N, Itoh H, Shirakami G, Nakagawa O, Suga S, Ogawa Y, Masuda I, Nakanishi K, Yoshimasa T, Hashimoto Y, .: Rapid ventricular induction of brain natriuretic peptide gene expression in experimental acute myocardial infarction. *Circulation* 1995;92:1558-1564.

478. Arakawa N, Nakamura M, Aoki H, Hiramori K: Relationship between plasma level of brain natriuretic peptide and myocardial infarct size. *Cardiology* 1994;85:334-340.
479. Ruskoaho H: Cardiac hormones as diagnostic tools in heart failure. *Endocr Rev* 2003;24:341-356.
480. Selvais PL, Donckier JE, Robert A, Laloux O, van Linden F, Ahn S, Ketelslegers JM, Rousseau MF: Cardiac natriuretic peptides for diagnosis and risk stratification in heart failure: influences of left ventricular dysfunction and coronary artery disease on cardiac hormonal activation. *Eur J Clin Invest* 1998;28:636-642.
481. Safley DM, McCullough PA: The emerging role of brain natriuretic peptide in the management of acute and chronic heart failure in outpatients. *Heart Fail Monit* 2003;4:13-20.
482. Ruskoaho H: Cardiac hormones as diagnostic tools in heart failure. *Endocr Rev* 2003;24:341-356.
483. McCullough PA: B-type natriuretic peptides. A diagnostic breakthrough in heart failure. *Minerva Cardioangiol* 2003;51:121-129.
484. Maisel A: B-type natriuretic peptide in the diagnosis and management of congestive heart failure. *Cardiol Clin* 2001;19:557-571.
485. de Lemos JA, McGuire DK, Drazner MH: B-type natriuretic peptide in cardiovascular disease. *Lancet* 2003;362:316-322.
486. Colli A, Fraquelli M, Conte D: B-type natriuretic peptide in heart failure. *N Engl J Med* 2002;347:1976-1978.
487. Burger MR, Burger AJ: BNP in decompensated heart failure: diagnostic, prognostic and therapeutic potential. *Curr Opin Investig Drugs* 2001;2:929-935.
488. Herrmann HC, Rosenthal AD, Davis CA: Cardiovascular effects of intracoronary atrial natriuretic peptide administration in man. *Am Heart J* 1990;120:308-315.
489. Lai CP, Egashira K, Tashiro H, Narabayashi H, Koyanagi S, Imaizumi T, Takeshita A: Beneficial effects of atrial natriuretic peptide on exercise-induced myocardial ischemia in patients with stable effort angina pectoris. *Circulation* 1993;87:144-151.
490. Nakamura M, Arakawa N, Kato M: Renal, hormonal, and hemodynamic effects of low-dose infusion of atrial natriuretic factor in acute myocardial infarction. *Am Heart J* 1990;120:1078-1085.
491. Kalra PR, Clague JR, Bolger AP, Anker SD, Poole-Wilson PA, Struthers AD, Coats AJ: Myocardial production of C-type natriuretic peptide in chronic heart failure. *Circulation* 2003;107:571-573.
492. Kalra PR, Anker SD, Struthers AD, Coats AJ: The role of C-type natriuretic peptide in cardiovascular medicine. *Eur Heart J* 2001;22:997-1007.

493. Burger MR, Burger AJ: BNP in decompensated heart failure: diagnostic, prognostic and therapeutic potential. *Curr Opin Investig Drugs* 2001;2:929-935.
494. Drazner M, McGuire DK, de Lemos JA: Nesiritide in acute heart failure. *Lancet* 2003;362:998-999.
495. Hobbs RE, Mills RM, Young JB: An update on nesiritide for treatment of decompensated heart failure. *Expert Opin Investig Drugs* 2001;10:935-942.
496. Moazemi K, Chana JS, Willard AM, Kocheril AG: Intravenous vasodilator therapy in congestive heart failure. *Drugs Aging* 2003;20:485-508.
497. Adams KF, Jr., Mathur VS, Gheorghide M: B-type natriuretic peptide: from bench to bedside. *Am Heart J* 2003;145:S34-S46.
498. Rifkin W: Nesiritide vs nitroglycerin for decompensated congestive heart failure. *JAMA* 2002;288:572-573.
499. Dunavant S: Nesiritide vs nitroglycerin for decompensated congestive heart failure. *JAMA* 2002;288:571-572.
500. Marcus LS, Hart D, Packer M, Yushak M, Medina N, Danziger RS, Heitjan DF, Katz SD: Hemodynamic and renal excretory effects of human brain natriuretic peptide infusion in patients with congestive heart failure. A double-blind, placebo-controlled, randomized crossover trial. *Circulation* 1996;94:3184-3189.
501. Metry G, Hall C, Wikstrom B, Kallskog V, Hansell P, Danielson B: Fluid balance in patients with chronic renal failure assessed with N-terminal proatrial natriuretic peptide, atrial natriuretic peptide and ultrasonography. *Acta Physiol Scand* 2001;171:117-122.
502. Franz M, Woloszczuk W, Horl WH: N-terminal fragments of the proatrial natriuretic peptide in plasma and urine of kidney graft recipients. *Transplantation* 2001;72:89-94.
503. Franz M, Woloszczuk W, Horl WH: Plasma concentration and urinary excretion of N-terminal proatrial natriuretic peptides in patients with kidney diseases. *Kidney Int* 2001;59:1928-1934.
504. Yamamoto Y, Higa T, Kitamura K, Tanaka K, Kangawa K, Matsuo H: Plasma concentration of human atrial natriuretic polypeptide in patients with impaired renal function. *Clin Nephrol* 1987;27:84-86.
505. Yamamoto Y, Higa T, Kitamura K, Tanaka K, Kangawa K, Matsuo H: Plasma concentration of atrial natriuretic polypeptide in chronic hemodialysis patients. *Regul Pept Suppl* 1985;4:110-112.
506. Tulassay T, Rascher W, Ganten D, Scharer K, Lang RE: Atrial natriuretic peptide and volume changes in children. *Clin Exp Hypertens A* 1986;8:695-701.
507. Rascher W, Bald M, Kroner F, Tulassay T, Muller-Wiefel DE: [Clinical relevance of the determination of plasma atrial natriuretic peptide in children with chronic renal failure]. *Z Kardiol* 1988;77 Suppl 2:61-64.

508. Rascher W, Tulassay T, Lang RE: Atrial natriuretic peptide in plasma of volume-overloaded children with chronic renal failure. *Lancet* 1985;2:303-305.
509. Talartschik J, Eisenhauer T, Voth E, Sold G, Scheler F: [Is the plasma ANP level an index of volume expansion in dialysis patients?]. *Z Kardiol* 1988;77 Suppl 2:72-77.
510. Eisenhauer T, Talartschik J, Scheler F: Detection of fluid overload by plasma concentration of human atrial natriuretic peptide (h-ANP) in patients with renal failure. *Klin Wochenschr* 1986;64 Suppl 6:68-72.
511. Wolfram G, Sitter T, Gottsmann M, Gerzer R, Schiffel H: Assessment of dry weight in haemodialysis patients by the volume markers ANP and cGMP. *Nephrol Dial Transplant* 1996;11 Suppl 2:28-30.
512. Kuwahara M, Matsushita K, Yoshinaga H, Aki M, Fujisaki N, Kagawa S: [Clinical significance of HANP (human atrial natriuretic peptide) in patients on maintenance hemodialysis--HANP as a parameter to determine the dry weight (D.W.)]. *Hinyokika Kyo* 1992;38:5-8.
513. Kowalska K, Grzeszczak W, Kowalski D: [Levels of endothelin and atrial natriuretic peptide (ANP) in plasma of patients with chronic renal failure treated by hemodialysis]. *Pol Arch Med Wewn* 1993;90:334-341.
514. Grzeszczak W, Kowalska K, Zukowska-szczechowska EA, Kowalski D, Snit M, Sornek E: [Level of atrial natriuretic peptide (ANP) in plasma of patients with chronic renal failure during hemodialysis]. *Pol Arch Med Wewn* 1995;93:107-113.
515. Eisenhauer T, Talartschik J, Quentin E, Kreutzfeldt W, Scheler F: [Modification of atrial natriuretic peptide (ANP) and cyclic GMP by hemofiltration and hemodialysis]. *Klin Wochenschr* 1988;66:940-945.
516. de Chatel R, Mako J, Toth M, Barna I, Lang RE: Atrial natriuretic peptide (ANP) in patients with chronic renal failure on maintenance haemodialysis. *Int Urol Nephrol* 1991;23:177-183.
517. Saxenhofer H, Gnadinger MP, Weidmann P, Shaw S, Schohn D, Hess C, Uehlinger DE, Jahn H: Plasma levels and dialysance of atrial natriuretic peptide in terminal renal failure. *Kidney Int* 1987;32:554-561.
518. Deray G, Maistre G, Cacoub P, Barthelemy C, Eurin J, Carayon A, Masson F, Martinez F, Baumelou A, Legrand JC, .: Renal and hemodialysis clearances of endogenous natriuretic peptide. A clinical and experimental study. *Nephron* 1990;54:148-153.
519. Franz M, Woloszczuk W, Horl WH: N-terminal fragments of the proatrial natriuretic peptide in patients before and after hemodialysis treatment. *Kidney Int* 2000;58:374-383.
520. Franz M, Pohanka E, Tribl B, Woloszczuk W, Horl WH: Living on chronic hemodialysis between dryness and fluid overload. *Kidney Int Suppl* 1997;59:S39-S42.
521. Ry SD, Clerico A, Giannessi D, Andreassi MG, Caprioli R, Iascone MR, Ferrazzi P, Biagini A: Measurement of brain natriuretic peptide in plasma samples and cardiac tissue extracts by means of an immunoradiometric assay method. *Scand J Clin Lab Invest* 2000;60:81-90.

522. Clerico A, Del Ry S, Giannessi D: Measurement of cardiac natriuretic hormones (atrial natriuretic peptide, brain natriuretic peptide, and related peptides) in clinical practice: the need for a new generation of immunoassay methods. *Clin Chem* 2000;46:1529-1534.
523. Clerico A, Iervasi G, Manfredi C, Salvadori S, Marastoni M, Del Chicca MG, Giannessi D, Del Ry S, Andreassi MG, Sabatino L, .: Preparation of mono-radioiodinated tracers for study of the in vivo metabolism of atrial natriuretic peptide in humans. *Eur J Nucl Med* 1995;22:997-1004.
524. Clerico A, Iervasi G, Del Chicca MG, Maffei S, Berti S, Sabatino L, Turchi S, Cazzuola F, Manfredi C, Biagini A: Analytical performance and clinical usefulness of a commercially available IRMA kit for measuring atrial natriuretic peptide in patients with heart failure. *Clin Chem* 1996;42:1627-1633.
525. Vesely DL, Douglass MA, Dietz JR, Gower WR, Jr., McCormick MT, Rodriguez-Paz G, Schocken DD: Three peptides from the atrial natriuretic factor prohormone amino terminus lower blood pressure and produce diuresis, natriuresis, and/or kaliuresis in humans. *Circulation* 1994;90:1129-1140.
526. Lewis HM, Ratcliffe WA, Stott RA, Wilkins MR, Baylis PH: Development and validation of a two-site immunoradiometric assay for human atrial natriuretic factor in unextracted plasma. *Clin Chem* 1989;35:953-957.
527. Tsuji T, Imagawa K, Masuda H, Haraikawa M, Shibata K, Kono M, Inouye K, Uchida K: Stabilization of human brain natriuretic peptide in blood samples. *Clin Chem* 1994;40:672-673.
528. Clerico A, Iervasi G, Del Chicca MG, Maffei S, Berti S, Sabatino L, Turchi S, Cazzuola F, Manfredi C, Biagini A: Analytical performance and clinical usefulness of a commercially available IRMA kit for measuring atrial natriuretic peptide in patients with heart failure. *Clin Chem* 1996;42:1627-1633.
529. Sagnella GA: Measurement and importance of plasma brain natriuretic peptide and related peptides. *Ann Clin Biochem* 2001;38:83-93.
530. Buckley MG, Markandu ND, Sagnella GA, MacGregor GA: N-terminal atrial natriuretic peptide and atrial natriuretic peptide in human plasma: investigation of plasma levels and molecular circulating form(s) using radioimmunoassays for pro-atrial natriuretic peptide (31-67), pro-atrial natriuretic peptide (1-30) and atrial natriuretic peptide (99-126). *Clin Sci (Lond)* 1994;87:311-317.
531. Franz M, Woloszczuk W, Horl WH: N-terminal fragments of the proatrial natriuretic peptide in patients before and after hemodialysis treatment. *Kidney Int* 2000;58:374-383.
532. Wieczorek SJ, Wu AH, Christenson R, Krishnaswamy P, Gottlieb S, Rosano T, Hager D, Gardetto N, Chiu A, Bailly KR, Maisel A: A rapid B-type natriuretic peptide assay accurately diagnoses left ventricular dysfunction and heart failure: a multicenter evaluation. *Am Heart J* 2002;144:834-839.
533. Karl J, Borgya A, Gallusser A, Huber E, Krueger K, Rollinger W, Schenk J: Development of a novel, N-terminal-proBNP (NT-proBNP) assay with a low detection limit. *Scand J Clin Lab Invest Suppl* 1999;230:177-181.

534. Del Ry S, Giannessi D, Clerico A: Plasma brain natriuretic peptide measured by fully-automated immunoassay and by immunoradiometric assay compared. *Clin Chem Lab Med* 2001;39:446-450.
535. Franz M, Woloszczuk W, Horl WH: N-terminal fragments of the proatrial natriuretic peptide in patients before and after hemodialysis treatment. *Kidney Int* 2000;58:374-383.
536. Metry G, Hall C, Wikstrom B, Kallskog V, Hansell P, Danielson B: Fluid balance in patients with chronic renal failure assessed with N-terminal proatrial natriuretic peptide, atrial natriuretic peptide and ultrasonography. *Acta Physiol Scand* 2001;171:117-122.
537. Fagugli RM, Palumbo B, Ricciardi D, Pasini P, Santirosi P, Vecchi L, Pasticci F, Palumbo R: Association between brain natriuretic peptide and extracellular water in hemodialysis patients. *Nephron Clin Pract* 2003;95:c60-c66.
538. Fagugli RM, Pasini P, Quintaliani G, Pasticci F, Ciao G, Cicconi B, Ricciardi D, Santirosi PV, Buoncristiani E, Timio F, Valente F, Buoncristiani U: Association between extracellular water, left ventricular mass and hypertension in haemodialysis patients. *Nephrol Dial Transplant* 2003;18:2332-2338.
539. Lee SW, Song JH, Kim GA, Lim HJ, Kim MJ: Plasma brain natriuretic peptide concentration on assessment of hydration status in hemodialysis patient. *Am J Kidney Dis* 2003;41:1257-1266.
540. Mallamaci F, Postorino M, Zoccali C: Influence of ANF on the cardiovascular response to volume expansion in haemodialysis patients. *Nephrol Dial Transplant* 1994;9:1279-1282.
541. Mallamaci F, Zoccali C, Tripepi G, Benedetto FA, Parlongo S, Cataliotti A, Cutrupi S, Giaccone G, Bellanuova I, Stancanelli B, Malatino LS: Diagnostic potential of cardiac natriuretic peptides in dialysis patients. *Kidney Int* 2001;59:1559-1566.
542. Goto T, Takase H, Toriyama T, Sugiura T, Kurita Y, Tsuru N, Masuda H, Hayashi K, Ueda R, Dohi Y: Increased circulating levels of natriuretic peptides predict future cardiac event in patients with chronic hemodialysis. *Nephron* 2002;92:610-615.
543. Naganuma T, Sugimura K, Wada S, Yasumoto R, Sugimura T, Masuda C, Uchida J, Nakatani T: The prognostic role of brain natriuretic peptides in hemodialysis patients. *Am J Nephrol* 2002;22:437-444.
544. Cataliotti A, Malatino LS, Jougasaki M, Zoccali C, Castellino P, Giaccone G, Bellanuova I, Tripepi R, Seminara G, Parlongo S, Stancanelli B, Bonanno G, Fatuzzo P, Rapisarda F, Belluardo P, Signorelli SS, Heublein DM, Lainchbury JG, Leskinen HK, Bailey KR, Redfield MM, Burnett JC, Jr.: Circulating natriuretic peptide concentrations in patients with end-stage renal disease: role of brain natriuretic peptide as a biomarker for ventricular remodeling. *Mayo Clin Proc* 2001;76:1111-1119.
545. Wang T, Cheng HH, Heimburger O, Chen C, Bergstrom J, Lindholm B: Intraperitoneal atrial natriuretic peptide increases peritoneal fluid and solute removal. *Kidney Int* 2001;60:513-519.
546. Shiota J, Kubota M, Shimada N, Ebihara I, Koide H: Plasma atrial natriuretic peptide levels in continuous ambulatory peritoneal dialysis patients. *Nephron* 1997;75:360-361.

547. Plum J, Schoenicke G, Kleophas W, Kulas W, Steffens F, Azem A, Grabensee B: Comparison of body fluid distribution between chronic haemodialysis and peritoneal dialysis patients as assessed by biophysical and biochemical methods. *Nephrol Dial Transplant* 2001;16:2378-2385.
548. Mora-Macia J, Donate T, Ocon J, Roda M, del Rio G: Atrial natriuretic factor in patients on continuous ambulatory peritoneal dialysis. *Perit Dial Int* 1993;13 Suppl 2:S190-S191.
549. Lauster F, Heim JM, Drummer C, Gerzer R, Schiffel H: Plasma ANP and cGMP levels in CAPD patients. *Contrib Nephrol* 1993;101:44-50.
550. Bald M, Bonzel KE, Rascher W: Atrial natriuretic peptide and cyclic guanosine-monophosphate in children and adolescents on peritoneal dialysis. *Clin Nephrol* 1994;42:50-53.
551. Ando R, Matsuda O, Miyake S, Yoshiyama N: Plasma levels of human atrial natriuretic factor in patients treated by hemodialysis and continuous ambulatory peritoneal dialysis. *Nephron* 1988;50:225-228.
552. Nakatani T, Naganuma T, Masuda C, Uchida J, Sugimura T, Sugimura K: Significance of brain natriuretic peptides in patients on continuous ambulatory peritoneal dialysis. *Int J Mol Med* 2002;10:457-461.
553. Totsune K, Takahashi K, Murakami O, Satoh F, Sone M, Mouri T: Elevated plasma C-type natriuretic peptide concentrations in patients with chronic renal failure. *Clin Sci (Lond)* 1994;87:319-322.
554. Yamasaki H, Nagake Y, Akagi S, Sugimoto T, Ichikawa H, Makino H: Plasma adrenomedullin levels in patients on hemodialysis. *Nephron* 2001;89:20-25.
555. Washimine H, Yamamoto Y, Kitamura K, Tanaka M, Ichiki Y, Kangawa K, Matsuo H, Eto T: Plasma concentration of human adrenomedullin in patients on hemodialysis. *Clin Nephrol* 1995;44:389-393.
556. Suda T, Osajima A, Iwamoto M, Anai H, Tamura M, Kabashima N, Ota T, Watanabe Y, Kanegae K, Okazaki M, Nakashima Y: The mature form of adrenomedullin correlates with brain natriuretic peptide in plasma of chronic hemodialysis patients. *Clin Nephrol* 2002;57:444-451.
557. Mallamaci F, Zoccali C, Parlongo S, Cutrupi S, Tripepi G, Postorino M: Plasma adrenomedullin during acute changes in intravascular volume in hemodialysis patients. *Kidney Int* 1998;54:1697-1703.
558. Kanozawa K, Shimosawa T, Nagasawa R, Matsuda A, Kato H, Matsumura O, Mitarai T, Isoda K, Fujita T: Mature form of adrenomedullin is a useful marker to evaluate blood volume in hemodialysis patients. *Am J Kidney Dis* 2002;40:794-801.
559. Allgren RL, Marbury TC, Rahman SN, Weisberg LS, Fenves AZ, Lafayette RA, Sweet RM, Genter FC, Kurnik BR, Conger JD, Sayegh MH: Anaritide in acute tubular necrosis. Auriculin Anaritide Acute Renal Failure Study Group. *N Engl J Med* 1997;336:828-834.

560. Weisberg LS, Allgren RL, Genter FC, Kurnik BR: Cause of acute tubular necrosis affects its prognosis. The Auriculin Anaritide Acute Renal Failure Study Group. *Arch Intern Med* 1997;157:1833-1838.
561. Wiebe K, Meyer M, Wahlers T, Zenker D, Schulze F, Michels P, Dalichau H, Mohr FW, Borst H, Forssmann WG: Acute renal failure following cardiac surgery is reverted by administration of Urodilatin (INN: Ularitide). *Eur J Med Res* 1996;1:259-265.
562. Langrehr JM, Kahl A, Meyer M, Neumann U, Knoop M, Jonas S, Steinmuller T, Bechstein WO, Frei U, Forssmann WG, Neuhaus P: Prophylactic use of low-dose urodilatin for prevention of renal impairment following liver transplantation: a randomized placebo-controlled study. *Clin Transplant* 1997;11:593-598.
563. Hummel M, Kuhn M, Bub A, Bittner H, Kleefeld D, Marxen P, Schneider B, Hetzer R, Forssmann WG: Urodilatin: a new peptide with beneficial effects in the postoperative therapy of cardiac transplant recipients. *Clin Investig* 1992;70:674-682.
564. Matthie J, Zarowitz B, De LA, Andreoli A, Katzarski K, Pan G, Withers P: Analytic assessment of the various bioimpedance methods used to estimate body water. *J Appl Physiol* 1998;84:1801-1816.
565. Matthie JR: Bioimpedance measurements of human body composition: critical analysis and outlook. *Expert Rev Med Devices* 2008;5:239-261.
566. Lennox, S. Studies on the variations in ANP concentrations in different age groups in health and disease, MD Thesis, University of Wales 1989
567. Yeo KT, Wu AH, Apple FS, Kroll MH, Christenson RH, Lewandrowski KB, Sedor FA, Butch AW: Multicenter evaluation of the Roche NT-proBNP assay and comparison to the Biosite Triage BNP assay. *Clin Chim Acta* 2003;338:107-115.
568. Shapiro BP, Chen HH, Burnett JC, Jr., Redfield MM: Use of plasma brain natriuretic peptide concentration to aid in the diagnosis of heart failure. *Mayo Clin Proc* 2003;78:481-486.
569. Vogeser M, Jacob K: B-type natriuretic peptide (BNP)--validation of an immediate response assay. *Clin Lab* 2001;47:29-33.
570. A Rapid, Quantitative Point-of-Care Assay System for the Measurement of B-type Natriuretic Peptide in Blood.
Heart. 83 SUPPLEMENT II:A14, June 2000.
McPherson, P H; Sundquist, A R; Anderberg, J M; Leseferko, S M; Nakamura, K K; Buechler, J A; Valkirs, G E; Bruni, J F; Buechler, K F
571. Henderson LW: Symptomatic hypotension during hemodialysis. *Kidney Int* 1980;17:571-576.
572. Cheigh JS, Milite C, Sullivan JF, Rubin AL, Stenzel KH: Hypertension is not adequately controlled in hemodialysis patients. *Am J Kidney Dis* 1992;19:453-459.
573. Charra B, Terrat JC, Vanel T, Chazot C, Jean G, Hurot JM, Lorriaux C: Long thrice weekly hemodialysis: the Tassin experience. *Int J Artif Organs* 2004;27:265-283.

574. Charra B, Chazot C, Jean G, Terrat JC, Vanel T, Hurot JM, Lorriaux C, VoVan C: Reverse epidemiology and hemodialysis blood pressure. *Kidney Int* 2003;64:2323-2324.
575. Charra B, Bergstrom J, Scribner BH: Blood pressure control in dialysis patients: importance of the lag phenomenon. *Am J Kidney Dis* 1998;32:720-724.
576. Jaeger JQ, Mehta RL: Assessment of dry weight in hemodialysis: an overview. *J Am Soc Nephrol* 1999;10:392-403.
577. Foley RN, Parfrey PS, Harnett JD, Kent GM, Murray DC, Barre PE: The prognostic importance of left ventricular geometry in uremic cardiomyopathy. *J Am Soc Nephrol* 1995;5:2024-2031.
578. Harnett JD, Foley RN, Kent GM, Barre PE, Murray D, Parfrey PS: Congestive heart failure in dialysis patients: prevalence, incidence, prognosis and risk factors. *Kidney Int* 1995;47:884-890.
579. Foley RN, Parfrey PS: Cardiovascular disease and mortality in ESRD. *J Nephrol* 1998;11:239-245.
580. Foley RN, Parfrey PS, Sarnak MJ: Epidemiology of cardiovascular disease in chronic renal disease. *J Am Soc Nephrol* 1998;9:S16-S23.
581. Levey AS, Beto JA, Coronado BE, Eknoyan G, Foley RN, Kasiske BL, Klag MJ, Mailloux LU, Manske CL, Meyer KB, Parfrey PS, Pfeffer MA, Wenger NK, Wilson PW, Wright JT, Jr.: Controlling the epidemic of cardiovascular disease in chronic renal disease: what do we know? What do we need to learn? Where do we go from here? National Kidney Foundation Task Force on Cardiovascular Disease. *Am J Kidney Dis* 1998;32:853-906.
582. Foley RN, Hakim RM: Why Is the Mortality of Dialysis Patients in the United States Much Higher than the Rest of the World? *J Am Soc Nephrol* 2009.
583. Charra B, Calemard M, Laurent G: Importance of treatment time and blood pressure control in achieving long-term survival on dialysis. *Am J Nephrol* 1996;16:35-44.
584. Heerspink HJ, Ninomiya T, Zoungas S, de ZD, Grobbee DE, Jardine MJ, Gallagher M, Roberts MA, Cass A, Neal B, Perkovic V: Effect of lowering blood pressure on cardiovascular events and mortality in patients on dialysis: a systematic review and meta-analysis of randomised controlled trials. *Lancet* 2009;373:1009-1015.
585. Thews O, Hutten H: A comprehensive model of the dynamic exchange processes during hemodialysis. *Med Prog Technol* 1990;16:145-161.
586. Thews O, Deuber HJ, Hutten H, Schulz W: Theoretical approach and clinical application of kinetic modelling in dialysis. *Nephrol Dial Transplant* 1991;6:180-192.
587. Ursino M, Coli L, La MG, Grilli CM, Dalmastrì V, Giudicissi A, Masotti P, Avanzolini G, Stefoni S, Bonomini V: A simple mathematical model of intradialytic sodium kinetics: "in vivo" validation during hemodialysis with constant or variable sodium. *Int J Artif Organs* 1996;19:393-403.
588. De Nicola L, Minutolo R, Gallo C, Zoccali C, Cianciaruso B, Conte M, Lupo A, Fuiano G, Gallucci M, Bonomini M, Chiodini P, Signoriello G, Bellizzi V, Mallamaci F, Nappi F, Conte G:

Management of hypertension in chronic kidney disease: the Italian multicentric study. *J Nephrol* 2005;18:397-404.

589. Malatino LS, Benedetto FA, Mallamaci F, Tripepi G, Zoccali C, Parlongo S, Cutrupi S, Marino C, Panuccio V, Garozzo M, Candela V, Bellanuova I, Cataliotti A, Rapisarda F, Fatuzzo P, Bonanno G, Seminara G, Stancanelli B, Tassone F, Labate C: Smoking, blood pressure and serum albumin are major determinants of carotid atherosclerosis in dialysis patients. CREED Investigators. Cardiovascular Risk Extended Evaluation in Dialysis patients. *J Nephrol* 1999;12:256-260.
590. Mallamaci F, Zoccali C, Parlongo S, Tripepi G, Benedetto FA, Cutrupi S, Bonanno G, Fatuzzo P, Rapisarda F, Seminara G, Stancanelli B, Bellanuova I, Cataliotti A, Malatino LS: Troponin is related to left ventricular mass and predicts all-cause and cardiovascular mortality in hemodialysis patients. *Am J Kidney Dis* 2002;40:68-75.
591. Panuccio V, Tripepi R, Tripepi G, Mallamaci F, Benedetto FA, Cataliotti A, Bellanuova I, Giacone G, Malatino LS, Zoccali C: Heart valve calcifications, survival, and cardiovascular risk in hemodialysis patients. *Am J Kidney Dis* 2004;43:479-484.
592. Zoccali C, Tripepi G, Mallamaci F: Predictors of cardiovascular death in ESRD. *Semin Nephrol* 2005;25:358-362.
593. Zoccali C, Benedetto FA, Tripepi G, Mallamaci F: Cardiac consequences of hypertension in hemodialysis patients. *Semin Dial* 2004;17:299-303.
594. Zoccali C, Benedetto FA, Mallamaci F, Tripepi G, Giacone G, Stancanelli B, Cataliotti A, Malatino LS: Left ventricular mass monitoring in the follow-up of dialysis patients: prognostic value of left ventricular hypertrophy progression. *Kidney Int* 2004;65:1492-1498.
595. Zoccali C, Benedetto FA, Mallamaci F, Tripepi G, Giacone G, Cataliotti A, Seminara G, Stancanelli B, Malatino LS: Prognostic value of echocardiographic indicators of left ventricular systolic function in asymptomatic dialysis patients. *J Am Soc Nephrol* 2004;15:1029-1037.
596. Zoccali C, Mallamaci F, Tripepi G: Hypertension as a cardiovascular risk factor in end-stage renal failure. *Curr Hypertens Rep* 2002;4:381-386.
597. Zoccali C, Mallamaci F, Tripepi G: Nocturnal hypoxemia predicts incident cardiovascular complications in dialysis patients. *J Am Soc Nephrol* 2002;13:729-733.
598. Charra B, Bergstrom J, Scribner BH: Blood pressure control in dialysis patients: importance of the lag phenomenon. *Am J Kidney Dis* 1998;32:720-724.
599. Mitra S, Chamney P, Greenwood R, Farrington K: Linear decay of relative blood volume during ultrafiltration predicts hemodynamic instability. *Am J Kidney Dis* 2002;40:556-565.
600. Locatelli F, Colzani S, D'amico M, Manzoni C, Di Filippo S: Dry weight and sodium balance. *Semin Nephrol* 2001;21:291-297.
601. Zucchelli P, Santoro A: Dry weight in hemodialysis: volemic control. *Semin Nephrol* 2001;21:286-290.

602. Stiller S, Wirtz D, Waterbar F, Gladziwa U, Dakshinamurty KV, Mann H: Less symptomatic hypotension using blood volume controlled ultrafiltration. *ASAIO Trans* 1991;37:M139-M141.
603. Donauer J, Bohler J: Rationale for the use of blood volume and temperature control devices during hemodialysis : *Kid Blo Pres Research* 26: 82-89 2003-10-11
604. Gotch FA, Keen ML, Yarian SR: An analysis of thermal regulation in hemodialysis with one and three compartment models. *ASAIO Trans* 35: 622-624, 1989
605. Schneditz D, Rosales L, Kaufman AM, Kaysen G, Levin NW : Heat accumulation with relative blood volume decrease: *Am J Kidney Dis* 40: 777-782, 2002
606. Maggiore Q, Pizzarelli F, Santoro A, Panzetta G, Bonforte G, Hannedouche T, de Lara MAA, Tsouras I, Loureiro A, Ponce P, Sulkova S, Van Roost G, Brink H, Kwan JT: The effects of control of thermal balance on vascular stability in hemodialysis patients: results of the European Randomised Clinical Trial: *Am J Kidney Dis* 40: 280-290, 2002
607. Keijman JMG, van der Sande FM, Kooman JP, Leunissen KML : Thermal energy balance and body temperature: comparison between isolated ultrafiltration and hemodialysis at different dialysate temperatures: *Nephrol Dial Transplant* 14: 2196-2200, 1999
608. Donauer J, Schweiger C, Rumberger B, Krumme B, Bohler J : Reduction of hypotensive side effects during online-haemodiafiltration and low temperature haemodialysis: *Nephrol Dial Transplant* 18: 1616-1622, 2003
609. Sheen V, Bhalla V, Tulua-Tata A, Bhalla MA, Weiss D, Chiu A, Abdeen O, Mullaney S, Maisel A: The use of B-type natriuretic peptide to assess volume status in patients with end-stage renal disease. *Am Heart J* 2007;153:244-245.
610. Kuwahara M, Matsushita K, Yoshinaga H, Aki M, Fujisaki N, Kagawa S: [Clinical significance of HANP (human atrial natriuretic peptide) in patients on maintenance hemodialysis--HANP as a parameter to determine the dry weight (D.W.)]. *Hinyokika Kyo* 1992;38:5-8.
611. Kowalska K, Grzeszczak W, Kowalski D: [Levels of endothelin and atrial natriuretic peptide (ANP) in plasma of patients with chronic renal failure treated by hemodialysis]. *Pol Arch Med Wewn* 1993;90:334-341.
612. Grzeszczak W, Kowalska K, Zukowska-szczechowska EA, Kowalski D, Snit M, Sornek E: [Level of atrial natriuretic peptide (ANP) in plasma of patients with chronic renal failure during hemodialysis]. *Pol Arch Med Wewn* 1995;93:107-113.
613. Eisenhauer T, Talartschik J, Quentin E, Kreutzfeldt W, Scheler F: [Modification of atrial natriuretic peptide (ANP) and cyclic GMP by hemofiltration and hemodialysis]. *Klin Wochenschr* 1988;66:940-945.
614. de Bold AJ, Borenstein HB, Veress AT, Sonnenberg H: A rapid and potent natriuretic response to intravenous injection of atrial myocardial extract in rats. *Life Sci* 1981;28:89-94.

615. Eisenhauer T, Talartschik J, Scheler F: Detection of fluid overload by plasma concentration of human atrial natriuretic peptide (h-ANP) in patients with renal failure. *Klin Wochenschr* 1986;64 Suppl 6:68-72.
616. Antonicelli R, Melappioni M, Campanari G, Foschi F, Panichi N, Paciaroni E: Evaluation of plasmatic ANP levels in subjects affected by essential arterial hypertension and in a group of patients undergoing dialysis. *Int J Cardiol* 1989;25 Suppl 1:S17-S23.
617. de Chatel R, Mako J, Toth M, Barna I, Lang RE: Atrial natriuretic peptide (ANP) in patients with chronic renal failure on maintenance haemodialysis. *Int Urol Nephrol* 1991;23:177-183.
618. Fincher ME, Campbell HT, Sklar AH, Caruana RJ, Lightfoot BO, Cheek PL, Smith KL, Hess CP: Atrial natriuretic peptide (ANP) is removed by peritoneal dialysis in humans. *Adv Perit Dial* 1989;5:16-19.
619. Lauster F, Heim JM, Drummer C, Gerzer R, Schiffel H: Plasma ANP and cGMP levels in CAPD patients. *Contrib Nephrol* 1993;101:44-50.
620. Plum J, Ziyae M, Kemmer FW, Passlick-Deetjen J, Grabensee B: Intraindividual comparison of ANP, cGMP and plasma catecholamines between HD and CAPD. *Adv Perit Dial* 1990;6:211-219.
621. Wolfram G, Sitter T, Gottsmann M, Gerzer R, Schiffel H: Assessment of dry weight in haemodialysis patients by the volume markers ANP and cGMP. *Nephrol Dial Transplant* 1996;11 Suppl 2:28-30.
622. Iwashima Y, Horio T, Takami Y, Inenaga T, Nishikimi T, Takishita S, Kawano Y: Effects of the creation of arteriovenous fistula for hemodialysis on cardiac function and natriuretic peptide levels in CRF. *Am J Kidney Dis* 2002;40:974-982.
623. Nishikimi T, Futoo Y, Tamano K, Takahashi M, Suzuki T, Minami J, Honda T, Uetake S, Asakawa H, Kobayashi N, Horinaka S, Ishimitsu T, Matsuoka H: Plasma brain natriuretic peptide levels in chronic hemodialysis patients: influence of coronary artery disease. *Am J Kidney Dis* 2001;37:1201-1208.
624. Osajima A, Okazaki M, Tamura M, Anai H, Kabashima N, Suda T, Iwamoto M, Ota T, Watanabe Y, Kanegae K, Nakashima Y: Comparison of plasma levels of mature adrenomedullin and natriuretic peptide as markers of cardiac function in hemodialysis patients with coronary artery disease. *Nephron* 2002;92:832-839.
625. Osajima A, Okazaki M, Kato H, Anai H, Tsuda Y, Segawa K, Tanaka H, Tamura M, Takasugi M, Nakashima Y: Clinical significance of natriuretic peptides and cyclic GMP in hemodialysis patients with coronary artery disease. *Am J Nephrol* 2001;21:112-119.
626. Osajima A, Okazaki M, Kato H, Anai H, Tsuda Y, Segawa K, Tanaka H, Tamura M, Takasugi M, Nakashima Y: Clinical significance of natriuretic peptides and cyclic GMP in hemodialysis patients with coronary artery disease. *Am J Nephrol* 2001;21:112-119.
627. Yandle TG, Richards AM, Nicholls MG, Cuneo R, Espiner EA, Livesey JH: Metabolic clearance rate and plasma half life of alpha-human atrial natriuretic peptide in man. *Life Sci* 1986;38:1827-1833.

628. Penney MD, Hampton D, Oleesky DA, Livingstone C, Mulkerrin E: Radioimmunoassays of arginine vasopressin and atrial natriuretic peptide: application of a common protocol for plasma extraction using Sep-Pak C18 cartridges. *Ann Clin Biochem* 1992;29 (Pt 6):652-658.